

**NAVAL SHIPS' TECHNICAL MANUAL**

**CHAPTER 561**

**SUBMARINE STEERING  
AND DIVING SYSTEMS**

THIS CHAPTER SUPERSEDES CHAPTER 561 DATED 31 DECEMBER 2000

DISTRIBUTION STATEMENT C: DISTRIBUTION AUTHORIZED TO U.S. GOVERNMENT AGENCIES AND THEIR CONTRACTORS: ADMINISTRATIVE AND OPERATIONAL USE (28 SEPTEMBER 1990). OTHER REQUESTS FOR THIS DOCUMENT WILL BE REFERRED TO THE NAVAL SEA SYSTEMS COMMAND (SEA-03P6).

DESTRUCTION NOTICE: DESTROY BY ANY METHOD THAT WILL PREVENT DISCLOSURE OF CONTENTS OR RECONSTRUCTION OF THE DOCUMENT.

PUBLISHED BY DIRECTION OF COMMANDER, NAVAL SEA SYSTEMS COMMAND.

---

**31 JUL 2003**



**REVISION RECORD**

<b>REVISION NO.</b>	<b>DATE</b>	<b>TITLE AND/OR BRIEF DESCRIPTION/PREPARING ACTIVITY</b>
5	JULY 31, 2003	PARAGRAPH(S) 561-2.8.2.1, 561-2.8.2.9, 561-2.8.2.10 AND 561-2.8.4.1 FIGURE(S) 561-C-1
<b>TMDERS/ACNS INCORPORATED:</b> Q90613-02-E031		



## TABLE OF CONTENTS

Chapter/Paragraph	Page
<b>561 SUBMARINE STEERING AND DIVING SYSTEMS</b> . . . . .	561-1
<b>SECTION 1. INTRODUCTION</b> . . . . .	561-1
561-1.1 TYPES OF HYDRAULIC SYSTEMS . . . . .	561-1
561-1.1.1 GENERAL. . . . .	561-1
561-1.1.2 VARIABLE PRESSURE SYSTEM (PRESSURE DEMAND). . . . .	561-1
561-1.1.3 CONSTANT-PRESSURE SYSTEM. . . . .	561-1
561-1.2 POWER SOURCES AND MODES OF OPERATION . . . . .	561-1
561-1.3 TYPES OF MANUAL CONTROL . . . . .	561-2
561-1.3.1 RATE CONTROL. . . . .	561-2
561-1.3.2 POSITION CONTROL. . . . .	561-2
561-1.4 AUTOMATIC MODES OF CONTROL . . . . .	561-3
561-1.4.1 GENERAL. . . . .	561-3
561-1.4.2 AUTOMATIC STEERING CONTROL. . . . .	561-3
561-1.4.3 AUTOMATIC DEPTH CONTROL. . . . .	561-3
561-1.4.4 COMBINED AUTOMATIC STEERING AND DIVING. . . . .	561-4
561-1.4.4.1 Controller Operation. . . . .	561-4
561-1.5 SYSTEM OPERATING PRESSURE . . . . .	561-4
561-1.6 TYPICAL DIVING CONTROL SYSTEM . . . . .	561-4
<b>SECTION 2. COMPONENTS: FUNCTION AND MAINTENANCE</b> . . . . .	561-12
561-2.1 CONTROL STATION COMPONENTS . . . . .	561-12
561-2.1.1 GENERAL. . . . .	561-12
561-2.1.2 WHEEL/COLUMN ASSEMBLIES. . . . .	561-13
561-2.1.3 EMERGENCY STEERING STICK. . . . .	561-14
561-2.1.4 CONTROL COLUMN MAINTENANCE. . . . .	561-14
561-2.2 SYNCHRO RESOLVERS . . . . .	561-15
561-2.3 TRANSLATOR SERVO AMPLIFIERS . . . . .	561-15
561-2.4 SERVO CONTROL VALVES . . . . .	561-16
561-2.4.1 GENERAL. . . . .	561-16
561-2.4.2 ELECTROHYDRAULIC SERVO VALVES. . . . .	561-16
561-2.4.2.1 SV-438-10P and SV-438-15P Servo Valves. . . . .	561-16
561-2.4.2.2 SV-438-10P Torque Motor Adapter. . . . .	561-17
561-2.4.2.3 Electrohydraulic Servo Valve Null Adjustment. . . . .	561-17
561-2.4.2.4 Bendix Valves. . . . .	561-17
561-2.4.3 MECHANICAL-HYDRAULIC SERVO VALVE. . . . .	561-20

## TABLE OF CONTENTS - Continued

Chapter/Paragraph	Page
561-2.4.3.1 SSN 688 Class - Bendix (Honeywell Corporation) Mechanical-Hydraulic Servo Valve. . . . .	561-21
561-2.4.3.2 TRIDENT Class - Sargent Mechanical-Hydraulic Servo Valve. . . . .	561-21
561-2.4.4 REFERENCE MANUALS. . . . .	561-23
561-2.4.5 FLOW RATE ADJUSTMENT. . . . .	561-24
561-2.4.5.1 Rate Adjustment Using Valve Flow Limiters. . . . .	561-24
561-2.4.5.2 Rate Adjustment Involving Servo Amplifiers. . . . .	561-25
561-2.4.6 SERVO VALVE REPAIR. . . . .	561-25
561-2.4.6.1 Shipboard Repair. . . . .	561-25
561-2.4.6.2 Depot Level Repair. . . . .	561-25
561-2.4.6.3 Test Stands and Equipment. . . . .	561-25
561-2.4.6.4 Servo Valve Filter Maintenance. . . . .	561-25
561-2.4.6.5 External Filters. . . . .	561-25
561-2.4.6.6 Internal Filters. . . . .	561-26
561-2.5 POWER TRANSFER VALVES . . . . .	561-26
561-2.5.1 GENERAL. . . . .	561-26
561-2.5.2 FUNCTIONAL DESCRIPTION. . . . .	561-27
561-2.5.3 INSTALLATION AND ASSEMBLY. . . . .	561-27
561-2.5.4 POWER TRANSFER VALVE PILOT VALVES. . . . .	561-27
561-2.6 CONTROL SURFACE ANGLE INDICATION SYSTEMS . . . . .	561-28
561-2.6.1 GENERAL. . . . .	561-28
561-2.6.2 NORMAL ANGLE INDICATION. . . . .	561-28
561-2.6.3 AUXILIARY ANGLE INDICATION. . . . .	561-28
561-2.6.4 MECHANICAL ANGLE INDICATORS. . . . .	561-29
561-2.6.4.1 General. . . . .	561-29
561-2.6.4.2 Control Surface Angle Reference. . . . .	561-29
561-2.6.4.3 Inspection Procedures. . . . .	561-29
561-2.6.4.4 Corrective Action. . . . .	561-29
561-2.6.4.5 Inspection of Angle Indicator and Feedback Transmitters. . . . .	561-30
561-2.7 STEERING AND DIVING HYDRAULIC CYLINDERS . . . . .	561-30
561-2.7.1 OVERVIEW. . . . .	561-30
561-2.7.2 PISTON ROD PACKING AND PISTON SEALS. . . . .	561-30
561-2.7.3 DYNAMIC SEAL LEAKAGE. . . . .	561-33
561-2.7.3.1 External Seals. . . . .	561-33
561-2.7.3.2 Internal Seals. . . . .	561-34
561-2.7.3.3 Criteria for External Seals. . . . .	561-34
561-2.7.3.4 New Seals. . . . .	561-34
561-2.7.3.5 Replacement Seals. . . . .	561-34
561-2.7.3.6 Criteria for Internal Seals. . . . .	561-34
561-2.7.3.7 Replacement Criteria. . . . .	561-34
561-2.7.3.8 Leakage After Seal Replacement. . . . .	561-34
561-2.7.3.9 Cylinder Seal Leakage Test. . . . .	561-34
561-2.7.3.10 Summary of Dynamic Seal Leakage Requirements. . . . .	561-38
561-2.7.4 REPLACEMENT OF PISTON ROD PACKING. . . . .	561-38

## TABLE OF CONTENTS - Continued

Chapter/Paragraph	Page
561-2.7.5 PISTON/CYLINDER HEAD CLEARANCE. . . . .	561-38
561-2.7.5.1 Recommended Verification Procedure. . . . .	561-38
561-2.7.5.2 Alternative Verification Procedure. . . . .	561-41
561-2.7.6 REMOVAL OF CYLINDER HEAD. . . . .	561-42
561-2.7.6.1 Torquing Of Cylinder Head Fasteners. . . . .	561-43
561-2.7.6.2 Torquing of Hydraulic Cylinder Foundation Fasteners. . . . .	561-43
561-2.7.6.3 Inspection of Ram Axial Movement. . . . .	561-43
561-2.7.6.4 Hydraulic Ram Movement. . . . .	561-46
561-2.7.6.5 Acceptable Ram Movement. . . . .	561-46
561-2.7.6.6 SUPERBOLT . . . . .	561-46
561-2.7.7 CYLINDER PISTON LOCKING DOWEL INSTALLATION. . . . .	561-46
561-2.7.7.1 Locking Dowel Misalignment. . . . .	561-47
561-2.7.7.2 Shimming to Obtain Locking Dowel Alinement. . . . .	561-48
561-2.7.7.3 Piston Locking Dowel Relocation. . . . .	561-48
561-2.7.8 STERN DIVING GEAR DIVE LIMIT STOP MECHANISMS. . . . .	561-48
561-2.7.8.1 SSN688 Class and SSBN726 Class Ram Stop Operation. . . . .	561-50
561-2.7.8.2 Correction of SSN688 Class Tailrod Stop Misalignment. . . . .	561-50
561-2.7.9 SSN637 CLASS FAIRWATER DIVING GEAR DIVE STOP PLATE INSTALLATION. . . . .	561-50
561-2.8 STEERING AND DIVING MECHANICAL GEAR . . . . .	561-50
561-2.8.1 TYPICAL STEERING AND DIVING GEAR ARRANGEMENTS. . . . .	561-50
561-2.8.2 STEERING AND DIVING LINKAGE COUPLING. . . . .	561-51
561-2.8.2.1 Coupling Installation Requirements. . . . .	561-56
561-2.8.2.2 Coupling Locking Bolts. . . . .	561-57
561-2.8.2.3 Coupling Disassembly. . . . .	561-58
561-2.8.2.4 Rod Rotation. . . . .	561-59
561-2.8.2.5 Shim Fitting. . . . .	561-59
561-2.8.2.6 Determining the Thickness of a Replacement Shim. . . . .	561-59
561-2.8.2.7 Determining the Thickness of a New Shim. . . . .	561-60
561-2.8.2.8 Maximum Allowable Shim Thickness Changes. . . . .	561-60
561-2.8.2.9 Reassembly of Couplings. . . . .	561-60
561-2.8.2.10 Additional Comments Applicable to Reassembly. . . . .	561-61
561-2.8.3 STEERING AND DIVING CONNECTING RODS. . . . .	561-62
561-2.8.3.1 Loose Coupling. . . . .	561-62
561-2.8.3.2 Removal of SSN 688 Class Through Hull Connecting Rods. . . . .	561-62
561-2.8.4 CONNECTING ROD LUBRICATION. . . . .	561-62
561-2.8.4.1 Rod Alinement Problems. . . . .	561-62
561-2.8.4.2 Rod Alinement Procedure. . . . .	561-63
561-2.8.4.3 SSN 637 Class Fairwater Diving Hydraulic Cylinder Alinement Procedure . . . . .	561-65
561-2.8.4.4 Rod Alinement Verification. . . . .	561-66
561-2.8.4.5 Correcting Rod Misalignment. . . . .	561-67
561-2.8.5 STEERING AND DIVING GUIDE CYLINDER ASSEMBLIES. . . . .	561-67
561-2.8.5.1 Guide Cylinder Construction. . . . .	561-71
561-2.8.5.2 Guide Cylinder Liner Rubber Sealant. . . . .	561-71
561-2.8.5.3 Guide Cylinder Liners Welded in Place. . . . .	561-72

## TABLE OF CONTENTS - Continued

Chapter/Paragraph	Page
561-2.8.5.4	Guide Cylinder Covers and Packing Retainers. . . . . 561-72
561-2.8.5.5	Guide Cylinder Piston. . . . . 561-72
561-2.8.6	TILLERS AND YOKES. . . . . 561-72
561-2.8.7	LOOSE TILLER NUTS. . . . . 561-73
561-2.8.8	EXCESS RADIAL TILLER/STOCK CLEARANCE. . . . . 561-76
561-2.8.9	CORROSION OF THE TILLER/STOCK MATING SURFACES. . . . . 561-76
561-2.8.10	LOOSE TILLER KEYS. . . . . 561-77
561-2.8.11	TILLER ARM BUSHINGS. . . . . 561-77
561-2.8.12	HARDSTOPS. . . . . 561-77
561-2.8.13	BEARINGS. . . . . 561-79
561-2.8.13.1	Bearing Lubrication. . . . . 561-79
561-2.8.13.2	Journal Bearings. . . . . 561-79
561-2.8.13.3	Spherical Bearings. . . . . 561-79
561-2.8.13.4	Thrust Bearings. . . . . 561-79
561-2.8.13.5	Bushings. . . . . 561-79
561-2.8.13.6	Guide Piston (crosshead) Pin Plugs. . . . . 561-80
561-2.8.13.7	Thrust Washers. . . . . 561-82
561-2.8.13.8	Rudder Carrier Bearings. . . . . 561-82
561-2.8.13.9	Bearing Clearances. . . . . 561-82
561-2.8.13.10	Bearing Clearance Tables. . . . . 561-84
561-2.8.13.11	Stern Planes Pintle Bearing Brackets and Assemblies. . . . . 561-84
561-2.8.13.12	Self-Lubricated Bearings . . . . . 561-84
561-2.8.14	FASTENERS. . . . . 561-84
561-2.8.15	STOCKS. . . . . 561-85
561-2.9	MOLECULAR METAL COATING FOR RESURFACING OF COMPONENTS . . 561-89
561-2.9.1	APPLICABLE COMPONENTS. . . . . 561-89
561-2.9.1.1	Application. . . . . 561-89
561-2.9.1.2	Restrictions and Reporting. . . . . 561-90
561-2.9.1.3	Control Surfaces. . . . . 561-90
<b>SECTION 3.</b>	<b>OPERATING LIMITATIONS . . . . . 561-90</b>
561-3.1	CONTROL SURFACE RATES . . . . . 561-90
561-3.2	CONTROL SURFACE RATE SELECTION . . . . . 561-90
561-3.3	ASTERN SPEED LIMITATIONS FOR SURFACE OPERATION OF THE RUDDER . . . . . 561-91
<b>SECTION 4.</b>	<b>OVERALL MATERIAL AND MAINTENANCE REQUIREMENTS . . . . . 561-92</b>
561-4.1	STEERING AND DIVING HYDRAULIC SYSTEM MATERIAL IDENTIFICATION AND CONTROL (LEVEL I) . . . . . 561-92
561-4.2	STEERING AND DIVING MATERIAL CERTIFICATION REQUIREMENTS FOR THE SUBMARINE SAFETY PROGRAM . . . . . 561-92



## TABLE OF CONTENTS - Continued

Chapter/Paragraph	Page
561-4.3 STEERING AND DIVING SYSTEM URO-MRCs . . . . .	561-93
<b>A. STEERING AND DIVING HYDRAULIC CYLINDER INTERNAL REPAIR . . . . .</b>	<b>A-1</b>
561-A.1 METHOD 1 . . . . .	A-1
561-A.2 METHOD 2 . . . . .	A-1
<b>B. STEERING AND DIVING HYDRAULIC CYLINDER HEAD SLEEVING         PROCEDURE . . . . .</b>	<b>B-1</b>
<b>C. STEERING AND DIVING HYDRAULIC CYLINDER HEAD BUSHING FOR         SSN 688 CLASS SUBMARINES . . . . .</b>	<b>C-1</b>
<b>D. STEERING AND DIVING HYDRAULIC CYLINDER HEAD BUSHING FOR         PRE SSN 688 CLASS SUBMARINES . . . . .</b>	<b>D-1</b>
<b>E. STEERING AND DIVING HYDRAULIC CYLINDER AND FOUNDATION         FITTED BOLT BUSHING . . . . .</b>	<b>E-1</b>
<b>F. STEERING AND DIVING GUIDE CYLINDER COVER BUSHING . . . . .</b>	<b>F-1</b>
<b>G. STEERING AND DIVING GUIDE CYLINDER PISTON BUSHING . . . . .</b>	<b>G-1</b>
<b>H. STEERING AND DIVING TILLER ARM BUSHING . . . . .</b>	<b>H-1</b>
<b>I. INSTALLATION OF SELF-LUBRICATED BEARINGS IN STEERING AND         DIVING OPERATING GEAR . . . . .</b>	<b>I-1</b>
561-I.1 GENERAL INFORMATION. . . . .	I-1
561-I.1.1 Summary of Bearing Repairs. . . . .	I-1
561-I.1.2 Qualified Bearing Materials. . . . .	I-3
561-I.1.3 Bearing Sizing Guidance. . . . .	I-5
561-I.1.3.1 Water Swell. . . . .	I-5
561-I.1.3.2 Differential Thermal Expansion. . . . .	I-5
561-I.1.3.3 Bearing Replacement Planning. . . . .	I-7
561-I.2 GENERAL REPAIR REQUIREMENTS. . . . .	I-8
561-I.2.1 Criteria For Repair. . . . .	I-8
561-I.2.2 Scope of Repair. . . . .	I-8
561-I.2.3 Bearing Materials. . . . .	I-8
561-I.2.4 Packaging, Labeling, And Handling Requirements. . . . .	I-8
561-I.2.5 Ordering Requirements. . . . .	I-9
561-I.2.6 Allowance For Final Machining. . . . .	I-9
561-I.2.7 Reuse of Existing Parts. . . . .	I-9
561-I.2.8 Fabrication Requirements. . . . .	I-9
561-I.2.9 Self-lubricated Material Machining. . . . .	I-10

## TABLE OF CONTENTS - Continued

Chapter/Paragraph	Page
561-I.2.10 Shop Practices. . . . .	I-10
561-I.2.11 Assembly Precautions. . . . .	I-10
561-I.2.12 As-installed Bearing Measurements. . . . .	I-11
561-I.2.13 Threaded Fasteners. . . . .	I-11
561-I.2.14 Removed Material. . . . .	I-11
561-I.2.15 Operating Gear Alignment. . . . .	I-11
561-I.2.16 Quality Assurance. . . . .	I-12
 561-I.3 CONNECTING ROD BEARING REPAIR. . . . .	 I-13
561-I.3.1 Purpose And Scope. . . . .	I-13
561-I.3.1.1 SSN 688 Class. . . . .	I-13
561-I.3.1.2 SSBN 726 Class. . . . .	I-13
561-I.3.2 Repair Requirements. . . . .	I-14
561-I.3.3 Detailed Installation Requirements . . . . .	I-14
561-I.3.3.1 For SSN 688 Class submarines. . . . .	I-15
561-I.3.4 Prior And/Or Concurrent Alterations. . . . .	I-16
561-I.3.4.1 SSN 688 Class. . . . .	I-16
561-I.3.4.2 SSBN 726 Class. . . . .	I-16
561-I.3.5 References. . . . .	I-16
561-I.3.5.1 MPR Drawing 1059-126-10. . . . .	I-16
561-I.3.5.2 NAVSEA Drawing 7006698. . . . .	I-16
561-I.3.5.3 NAVSEA Drawing 4403809. . . . .	I-16
561-I.3.5.4 NAVSEA Drawing 6225162. . . . .	I-16
561-I.3.5.5 NAVSEA Drawing 4403812. . . . .	I-16
561-I.3.5.6 NAVSEA Drawing 4403816. . . . .	I-16
561-I.3.5.7 NAVSEA Drawing 4457075. . . . .	I-16
561-I.3.5.8 NAVSEA Drawing 4457076. . . . .	I-17
561-I.3.5.9 NAVSEA Drawing 4457079. . . . .	I-17
561-I.3.5.10 NAVSEA Drawing 4457080. . . . .	I-17
561-I.3.5.11 NAVSEA Drawing 4457125. . . . .	I-17
561-I.3.5.12 NAVSEA Drawing 4457126. . . . .	I-17
561-I.3.5.13 NAVSEA Drawing 4643331. . . . .	I-17
561-I.3.5.14 NAVSEA Drawing 4643344. . . . .	I-17
561-I.3.5.15 NAVSEA Drawing 4643402. . . . .	I-17
561-I.3.5.16 NAVSEA Drawing 4674747. . . . .	I-17
561-I.3.5.17 NAVSEA Drawing 4674753. . . . .	I-17
561-I.3.5.18 NAVSEA Drawing 4674761. . . . .	I-17
561-I.3.5.19 NAVSEA Drawing 4674799. . . . .	I-17
561-I.3.5.20 NAVSEA Drawing 4674802. . . . .	I-17
561-I.3.5.21 Maintenance Standard (MS) 5560-081-005. . . . .	I-17
561-I.3.5.22 Maintenance Standard (MS) 5560-081-006. . . . .	I-17
561-I.3.5.23 Maintenance Standard (MS) 5560-081-007. . . . .	I-17
561-I.3.5.24 Maintenance Standard (MS) 5560-081-008. . . . .	I-17
561-I.3.5.25 Maintenance Standard (MS) 5560-081-009. . . . .	I-17
561-I.3.5.26 Maintenance Standard (MS) 5560-081-033. . . . .	I-17
561-I.3.5.27 Maintenance Standard (MS) 5560-081-037. . . . .	I-17
561-I.3.5.28 Maintenance Standard (MS) 5560-081-038. . . . .	I-17

## TABLE OF CONTENTS - Continued

Chapter/Paragraph		Page
561-I.3.5.29	General Dynamics, EBDiv Drawing 41052-566000. . . . .	I-18
561-I.3.5.30	General Dynamics, EBDiv Drawing 41053-566000. . . . .	I-18
561-I.3.5.31	General Dynamics, EBDiv Drawing 41054-566000. . . . .	I-18
561-I.3.5.32	General Dynamics, EBDiv Drawing 41032-566000. . . . .	I-18
561-I.3.5.33	General Dynamics, EBDiv Drawing 41058-566000. . . . .	I-18
561-I.3.5.34	General Dynamics, EBDiv Drawing 41049-566000. . . . .	I-18
561-I.3.5.35	General Dynamics, EBDiv Drawing 41034-566000. . . . .	I-18
561-I.3.5.36	DTRC 9073 Code 2744POP. . . . .	I-18
561-I.3.6	Maintenance Requirement Parts List. . . . .	I-18
561-I.3.7	Final Inspection. . . . .	I-19
561-I.4	GUIDE PISTON REPAIR. . . . .	I-25
561-I.4.1	Purpose And Scope. . . . .	I-25
561-I.4.1.1	SSN 688 Class: . . . . .	I-25
561-I.4.1.2	SSBN 726 Class: . . . . .	I-25
561-I.4.2	Repair Requirements. . . . .	I-26
561-I.4.3	Detailed Installation Requirements. . . . .	I-26
561-I.4.4	Prior And/or Concurrent Alterations. . . . .	I-28
561-I.4.5	References. . . . .	I-28
561-I.4.5.1	MPR Drawing 1059-126-62. . . . .	I-28
561-I.4.5.2	NAVSEA Drawing 7006697. . . . .	I-28
561-I.4.5.3	NAVSEA Drawing 7006700. . . . .	I-28
561-I.4.5.4	Puget Sound Naval Shipyard Drawing 5307865. . . . .	I-28
561-I.4.5.5	MPR Report, MPR-1090. . . . .	I-28
561-I.4.5.6	MPR Report, MPR-1746. . . . .	I-28
561-I.4.5.7	NAVSEA Drawing 4457075. . . . .	I-28
561-I.4.5.8	NAVSEA Drawing 4457076. . . . .	I-29
561-I.4.5.9	NAVSEA Drawing 4457079. . . . .	I-29
561-I.4.5.10	NAVSEA Drawing 4457080. . . . .	I-29
561-I.4.5.11	NAVSEA Drawing 4457125. . . . .	I-29
561-I.4.5.12	NAVSEA Drawing 4457126. . . . .	I-29
561-I.4.5.13	NAVSEA Drawing 4674747. . . . .	I-29
561-I.4.5.14	NAVSEA Drawing 4674753. . . . .	I-29
561-I.4.5.15	NAVSEA Drawing 4674761. . . . .	I-29
561-I.4.5.16	NAVSEA Drawing 4674799. . . . .	I-29
561-I.4.5.17	NAVSEA Drawing 4674802. . . . .	I-29
561-I.4.5.18	Maintenance Standard (MS) 5560-081-005. . . . .	I-29
561-I.4.5.19	Maintenance Standard (MS) 5560-081-006. . . . .	I-29
561-I.4.5.20	Maintenance Standard (MS) 5560-081-007. . . . .	I-29
561-I.4.5.21	Maintenance Standard (MS) 5560-081-008. . . . .	I-29
561-I.4.5.22	Maintenance Standard (MS) 5560-081-009. . . . .	I-29
561-I.4.5.23	Maintenance Standard (MS) 5560-081-033. . . . .	I-29
561-I.4.5.24	Maintenance Standard (MS) 5560-081-037. . . . .	I-29
561-I.4.5.25	Maintenance Standard (MS) 5560-081-038. . . . .	I-29
561-I.4.5.26	General Dynamics, EBDiv Drawing 41053-566000. . . . .	I-29
561-I.4.5.27	General Dynamics, EBDiv Drawing 41055-566000. . . . .	I-29
561-I.4.5.28	General Dynamics, EBDiv Drawing 41058-566000. . . . .	I-29

## TABLE OF CONTENTS - Continued

Chapter/Paragraph	Page
561-I.4.5.29 General Dynamics, EBDiv Drawing 41050-566000. . . . .	I-30
561-I.4.5.30 General Dynamics, EBDiv Drawing 41034-566000. . . . .	I-30
561-I.4.6 Maintenance Requirement Parts List. . . . .	I-30
561-I.4.7 Final Inspection. . . . .	I-30
561-I.5 THROUGH-HULL ROD SUPPORT BEARING REPAIR. . . . .	I-32
561-I.5.1 Purpose And Scope. . . . .	I-32
561-I.5.2 Repair Requirements. . . . .	I-33
561-I.5.3 Detailed Installation Requirements. . . . .	I-33
561-I.5.4 Prior And/or Concurrent Alterations. . . . .	I-34
561-I.5.5 References. . . . .	I-34
561-I.5.5.1 NAVSEA Drawing 7006697. . . . .	I-34
561-I.5.5.2 NAVSEA Drawing 7006699. . . . .	I-34
561-I.5.5.3 Drawing for SSN 688 Class. . . . .	I-34
561-I.5.5.4 Report MPR-1760. . . . .	I-34
561-I.5.5.5 NAVSEA Drawing 4456071. . . . .	I-34
561-I.5.5.6 NAVSEA Drawing 4457075. . . . .	I-34
561-I.5.5.7 NAVSEA Drawing 4457077. . . . .	I-34
561-I.5.5.8 NAVSEA Drawing 4457079. . . . .	I-35
561-I.5.5.9 NAVSEA Drawing 4457081. . . . .	I-35
561-I.5.5.10 NAVSEA Drawing 4674747. . . . .	I-35
561-I.5.5.11 NAVSEA Drawing 4674751. . . . .	I-35
561-I.5.5.12 NAVSEA Drawing 4674752. . . . .	I-35
561-I.5.5.13 NAVSEA Drawing 4674753. . . . .	I-35
561-I.5.5.14 NAVSEA Drawing 4674761. . . . .	I-35
561-I.5.5.15 Maintenance Standard (MS) 5560-081-006. . . . .	I-35
561-I.5.5.16 Maintenance Standard (MS) 5560-081-007. . . . .	I-35
561-I.5.5.17 Maintenance Standard (MS) 5560-081-033. . . . .	I-35
561-I.5.5.18 Maintenance Standard (MS) 5560-081-037. . . . .	I-35
561-I.5.5.19 Maintenance Standard (MS) 5560-081-038. . . . .	I-35
561-I.5.5.20 General Dynamics, EBDiv Drawing 41056-566000. . . . .	I-35
561-I.5.5.21 General Dynamics, EBDiv Drawing 41051-566000. . . . .	I-35
561-I.5.5.22 Report MPR-1153. . . . .	I-35
561-I.5.5.23 Report 9560-SMMS-REP. . . . .	I-35
561-I.5.6 Maintenance Requirement Parts List. . . . .	I-35
561-I.5.7 Final Inspection. . . . .	I-36
561-I.6 FAIRWATER PLANES STOCK BEARING REPAIR. . . . .	I-36
561-I.6.1 Purpose And Scope. . . . .	I-36
561-I.6.2 Repair Requirements. . . . .	I-37
561-I.6.3 Detailed Installation Requirements. . . . .	I-37
561-I.6.4 Prior And/or Concurrent Alterations. . . . .	I-41
561-I.6.4.1 SSN 688 Class: . . . . .	I-41
561-I.6.4.2 SSBN 726 Class: . . . . .	I-41
561-I.6.5 References. . . . .	I-41
561-I.6.5.1 MPR Drawing 1059-126-13. . . . .	I-41
561-I.6.5.2 General Dynamics, EBDiv, Engineering Notice DM 120888. . . . .	I-41

## TABLE OF CONTENTS - Continued

Chapter/Paragraph		Page
	561-I.6.5.3 NAVSEA Drawing 4403812. . . . .	I-41
	561-I.6.5.4 NAVSEA Drawing 4643402. . . . .	I-41
	561-I.6.5.5 NAVSEA Drawing 4673405. . . . .	I-41
	561-I.6.5.6 Maintenance Standard (MS) 5560-081-005. . . . .	I-41
	561-I.6.5.7 Maintenance Standard (MS) 5560-081-037. . . . .	I-41
	561-I.6.5.8 General Dynamics, EBDiv Drawing 41024-566000. . . . .	I-41
	561-I.6.5.9 Report MPR-1017. . . . .	I-42
	561-I.6.5.10 DTRC 9073 Code 2744POP: David Taylor Research Center. . .	I-42
561-I.6.6	Maintenance Requirement Parts List. . . . .	I-42
561-I.6.7	Final Inspection. . . . .	I-42
561-I.7	STERN PLANES STOCK BEARING REPAIR. . . . .	I-44
561-I.7.1	Purpose And Scope. . . . .	I-44
561-I.7.2	Repair Requirements. . . . .	I-45
561-I.7.3	Detailed Installation Requirements. . . . .	I-45
561-I.7.4	Prior And/or Concurrent Alterations. . . . .	I-48
	561-I.7.4.1 SSN 688 Class: . . . . .	I-48
	561-I.7.4.2 SSBN 726 Class: . . . . .	I-48
561-I.7.5	References. . . . .	I-48
	561-I.7.5.1 MPR Drawing 1059-126-37. . . . .	I-48
	561-I.7.5.2 General Dynamics, EBDiv, Engineering Notice DM 120889. . .	I-48
	561-I.7.5.3 NAVSEA Drawing 4403816. . . . .	I-48
	561-I.7.5.4 NAVSEA Drawing 4643344. . . . .	I-48
	561-I.7.5.5 Maintenance Standard (MS) 5560-081-008. . . . .	I-48
	561-I.7.5.6 Maintenance Standard (MS) 5560-081-038. . . . .	I-48
	561-I.7.5.7 General Dynamics, EBDiv Drawing 41021-566000. . . . .	I-48
561-I.7.6	Maintenance Requirement Parts List. . . . .	I-48
561-I.7.7	Final Inspection. . . . .	I-48
561-I.8	STERN DIVING PLANES PINTLE BEARING REPAIR. . . . .	I-50
561-I.8.1	Purpose And Scope. . . . .	I-50
561-I.8.2	Repair Requirements. . . . .	I-51
561-I.8.3	Detailed Installation Requirements. . . . .	I-51
561-I.8.4	Prior And/or Concurrent Alterations. . . . .	I-53
	561-I.8.4.1 SSN 688 Class: . . . . .	I-54
	561-I.8.4.2 SSBN 726 Class: . . . . .	I-54
561-I.8.5	References. . . . .	I-54
	561-I.8.5.1 MPR Drawing 1059-126-35. . . . .	I-54
	561-I.8.5.2 General Dynamics, EBDiv, Engineering Notice DM 120889. . .	I-54
	561-I.8.5.3 NAVSEA Drawing 4403816. . . . .	I-54
	561-I.8.5.4 NAVSEA Drawing 4643344. . . . .	I-54
	561-I.8.5.5 Maintenance Standard (MS) 5560-081-008. . . . .	I-54
	561-I.8.5.6 Maintenance Standard (MS) 5560-081-038. . . . .	I-54
	561-I.8.5.7 General Dynamics, EBDiv Drawing 41057-566000. . . . .	I-54
561-I.8.6	Maintenance Requirement Parts List. . . . .	I-54
561-I.8.7	Final Inspection. . . . .	I-54

## TABLE OF CONTENTS - Continued

Chapter/Paragraph	Page
561-I.9 RUDDER STOCK AND CARRIER BEARING REPAIR. . . . .	I-56
561-I.9.1 Purpose And Scope. . . . .	I-56
561-I.9.2 Repair Requirements. . . . .	I-57
561-I.9.3 Detailed Installation Requirements. . . . .	I-58
561-I.9.4 Prior And/or Concurrent Alterations. . . . .	I-60
561-I.9.4.1 SSN 688 Class: . . . . .	I-60
561-I.9.4.2 SSBN 726 Class: . . . . .	I-60
561-I.9.5 References. . . . .	I-60
561-I.9.5.1 MPR Drawing 1059-126-39. . . . .	I-60
561-I.9.5.2 General Dynamics, EBDiv, Engineering Notice DM 120890. . .	I-60
561-I.9.5.3 NAVSEA Drawing 4403809. . . . .	I-60
561-I.9.5.4 NAVSEA Drawing 6225162. . . . .	I-60
561-I.9.5.5 NAVSEA Drawing 4403810. . . . .	I-60
561-I.9.5.6 NAVSEA Drawing 4643331. . . . .	I-60
561-I.9.5.7 NAVSEA Drawing 4643334. . . . .	I-60
561-I.9.5.8 Maintenance Standard (MS) 5560-081-009. . . . .	I-61
561-I.9.5.9 Maintenance Standard (MS) 5560-081-033. . . . .	I-61
561-I.9.5.10 General Dynamics, EBDiv Drawing 41022-566000. . . . .	I-61
561-I.9.5.11 General Dynamics, EBDiv Drawing 41033-566000. . . . .	I-61
561-I.9.6 Maintenance Requirement Parts List. . . . .	I-61
561-I.9.7 Final Inspection. . . . .	I-61
561-I.10 MACHINING REQUIREMENTS FOR SELF-LUBRICATED BEARING MATERIALS. . . . .	I-63
561-I.10.1 Purpose. . . . .	I-63
561-I.10.2 Machining Requirements. . . . .	I-63
561-I.10.3 UHMWPE. . . . .	I-64
561-I.10.4 TufLite. . . . .	I-64
561-I.10.5 Orkot TXM/TLM-Marine. . . . .	I-65
<b>J. BOW PLANE OUTBOARD CABLE INTEGRITY . . . . .</b>	<b>J-1</b>
561-J.1 Determining Material Condition of Retractable Bow Plane (RBP) Outboard Sensor Cabling Assemblies . . . . .	J-1
561-J.2 Verification of Replacement Cable Integrity . . . . .	J-1
561-J.3 Care in Replacing Cable . . . . .	J-1
<b>Technical Manual Deficiency/Evaluation Report (TMDER) . . . . .</b>	<b>0-1</b>

## LIST OF TABLES

Table	Title	Page
561-1-1.	HYDRAULIC POWER SOURCES FOR STEERING AND DIVING . . . . .	561-3
561-2-1	SERVO VALVE APPLICABILITY . . . . .	561-24
561-2-2	SUMMARY OF DYNAMIC SEAL ALLOWABLE LEAKAGE RATES <sup>NOTE 1</sup> . . .	561-39
561-2-3	ALLOWABLE CYLINDER AND PISTON ROD LEAKAGE . . . . .	561-40
561-2-4	PACKING GLAND FASTENER TORQUES (FT-LB) . . . . .	561-41
561-2-5	TORQUING OF CYLINDER HEAD FASTENERS . . . . .	561-43
561-2-6	TABLE OF TORQUE VALUES AND SELF-LOCKING NUT PART NUMBERS - For Ram Foundation Fasteners . . . . .	561-44
561-2-7	HYDRAULIC RAM MOVEMENT . . . . .	561-47
561-2-8	SHEET STOCK MATERIAL FOR CYLINDER PISTON ALINEMENT SHIMS . .	561-50
561-2-9	TABLE OF TORQUE VALUES FOR COUPLING . . . . .	561-57
561-2-10	RODS OF DIFFERENT DIAMETERS (ALTERNATE METHOD) . . . . .	561-65
561-2-11	CROSSHEAD PIN PLUG DIMENSIONS . . . . .	561-82
561-2-12	STEERING AND DIVING BEARING CLEARANCES . . . . .	561-85
561-A-1	DIMENSIONS FOR STEERING AND DIVING HYDRAULIC CYLINDER INTERNAL SLEEVING CLASS CYLINDER DIMENSION A REFERENCE . .	A-1
561-B-1	DIMENSIONS FOR HYDRAULIC CYLINDER HEAD SLEEVING . . . . .	B-2
561-C-1	DIMENSIONS FOR 688 CLASS HYDRAULIC CYLINDER HEAD BUSHING . .	C-3
561-D-1	DIMENSIONS FOR PRE 688 CLASS HYDRAULIC CYLINDER HEAD BUSHING . . . . .	D-2
561-E-1	DIMENSIONS FOR STEERING AND DIVING HYDRAULIC CYLINDER AND FOUNDATION FITTED BOLT BUSHINGS . . . . .	E-2
561-F-1	DIMENSIONS FOR STEERING AND DIVING GUIDE CYLINDER COVER BUSHING . . . . .	F-3
561-G-1	DIMENSIONS FOR GUIDE CYLINDER PISTON BUSHING STEERING GEAR . .	G-3
561-H-1	DIMENSIONS FOR STEERING AND DIVING TILLER ARM BUSHING STERN GEAR . . . . .	H-2
561-I-1	SSN 688 Class Submarine Steering & Diving Bearing Replacements . . . . .	I-1
561-I-2	SSBN 726 Class Submarine Steering & Diving Bearing Replacements . . . . .	I-2
561-I-3	Qualified Self-Lubricated Bearing Materials . . . . .	I-3



**LIST OF TABLES - Continued**

Table	Title	Page
561-I-4	Characteristics of Selected Self-lubricated Bearing Materials . . . . .	I-4
561-I-5	Summary of SSN 688 Class Connecting Rod Bearing Material Replacements . . . .	I-22
561-I-6	Summary of SSBN 726 Class Connecting Rod Bearing Material Replacements . . .	I-23
561-I-7	SSN 688 Class Submarines -- Standardized TufLite Bushing Sizes (inch) . . . . .	I-24
561-I-8	SSN 688 Class Submarines -- Standardized Orkot Bushing Sizes (inch) . . . . .	I-25
561-I-9	Summary of SSN 688 Class Guide Piston Modification Material Replacements . . .	I-32
561-I-10	Summary of SSBN 726 Class Guide Piston Modification Material Replacements . .	I-32
561-I-11	Summary of SSN 688 Class Operating Rod Support Bearing Material Replacements . . . . .	I-36
561-I-12	Summary of SSBN 726 Class Operating Rod Support Bearing Material Replacements . . . . .	I-36
561-I-13	Summary of SSN 688 Class Fairwater Stock Bearing Material Replacements . . . .	I-44
561-I-14	Summary of SSBN 726 Class Fairwater Stock Bearing Material Replacements . . .	I-44
561-I-15	Summary of SSN 688 Class Stern Plane Stock Bearing Material Replacements . . .	I-50
561-I-16	Summary of SSBN 726 Class Stern Plane Stock Bearing Material Replacements . .	I-50
561-I-17	Summary of SSN 688 Class Stern Plane Pintle Bearing Material Replacements . . .	I-56
561-I-18	Summary of SSBN 726 Class Stern Plane Pintle Bearing Material Replacements . .	I-56
561-I-19	Summary of SSN 688 Class Rudder Stock and Carrier Bearing Material Replacements . . . . .	I-63
561-I-20	Summary of SSBN 726 Class Rudder Stock and Carrier Bearing Material Replacements . . . . .	I-63



## LIST OF ILLUSTRATIONS

Figure	Title	Page
561-1-1.	Typical Stern Diving Control System Simplified Block Diagram (Sheet 1 of 2) . . .	561-5
561-1-1.	Typical Stern Diving Control System Simplified Block Diagram (Sheet 2 of 2) . . .	561-7
561-1.2	Typical Stern Arrangement for SSN 688 Class . . . . .	561-10
561-1-3	Stern Arrangement for SSN 718 with Split Stern Planes . . . . .	561-11
561-2-1.	Typical Steering and Diving Control Station . . . . .	561-13
561-2-2.	Servo Valve, Cross-Sectional View . . . . .	561-17
561-2-3.	SSN 688 Servo Valve, Functional Diagram . . . . .	561-19
561-2-4.	TRIDENT Class Servo Valve, Functional Diagram . . . . .	561-20
561-2-5.	SSN 688 Class Mechanical-Hydraulic Servo System (Emergency Mode) . . . . .	561-22
561-2-6.	TRIDENT Class Mechanical-Hydraulic Servo System (Emergency Mode) . . . . .	561-23
561-2-7.	Typical Steering and Diving Hydraulic Cylinder . . . . .	561-31
561-2-8	Cylinder Double Packing Secondary (Inner) Packing Engaged . . . . .	561-32
561-2-9	Cylinder Double Packing Primary (Outer) Packing Engaged . . . . .	561-33
561-2-10.	Cylinder Seal Leakage Test (Applicable to SSN637 Class and SSN642) . . . . .	561-35
561-2-11.	Cylinder Seal Leakage Test With Power Transfer Valve Attached (Applicable to SSN 688 Class and SSBN 726 Class) . . . . .	561-36
561-2-12.	Piston/Head Clearance Determination . . . . .	561-42
561-2-13.	Hydraulic Ran Axial Movement Inspection . . . . .	561-47
561-2-14.	Hydraulic Cylinder Piston Alinement and Locking Dowel Relocation . . . . .	561-49
561-2-15.	Step Key Slot . . . . .	561-52
561-2-16.	General Arrangement of Steering and Stern Diving Gear . . . . .	561-53
561-2-17.	Fairwater Diving Arrangement . . . . .	561-54
561-2-18.	SSN 688 Class Retractable Bow Planes Arrangement (Extended Position) . . . . .	561-55
561-2-19.	Coupling Arrangement . . . . .	561-56
561-2-20.	Location of Alinement Marks . . . . .	561-59
561-2-21.	Rod Alinement Check With Coupling Removed . . . . .	561-64
561-2-22.	Guide Cylinder and Connecting Rod . . . . .	561-68

**LIST OF ILLUSTRATIONS - Continued**

Figure	Title	Page
561-2-23.	"Dummy" Inner Piston Rod . . . . .	561-69
561-2-24.	Fairwater Planes Ram Alinement . . . . .	561-70
561-2-25.	Stock Bearing Clearance Inspection . . . . .	561-74
561-2-26.	Stock Bearing Clearance Inspection for Ships with ShipALT SSBN 1996 . . . . .	561-75
561-2-27.	Fairwater Planes Tiller Inspection . . . . .	561-76
561-2-28.	Hard Stop Approximate Percentage of Contact . . . . .	561-78
561-2-29.	Stern Diving Plane . . . . .	561-80
561-2-30.	Rudder Assembly . . . . .	561-81
561-2-31.	Typical Outboard Bearing . . . . .	561-83
561-2-32	Typical Rudder Spherical Bearing . . . . .	561-84
561-A-1	Steering and Diving Hydraulic Cylinder Internal Sleeving . . . . .	A-2
561-B-1.	Typical Hydraulic Cylinder Head Sleeving . . . . .	B-2
561-C-1	Typical 688 Class Hydraulic Cylinder Head Bushing . . . . .	C-2
561-D-1	Typical Pre 688 Class Hydraulic Cylinder Head Bushing . . . . .	D-2
561-E-1	Steering and Diving Hydraulic Cylinder and Foundation Fitted Bolt Bushing . . . . .	E-2
561-F-1	Guide Cylinder Cover Bushing . . . . .	F-2
561-G-1	Guide Cylinder Piston Bushing . . . . .	G-2
561-H-1	Steering and Diving Tiller Arm Bushing . . . . .	H-2
561-I-1	Effect of Water Swell on Bearing Clearance . . . . .	I-5
561-I-2	Effect of Thermal Expansion on Bearing Clearance . . . . .	I-6
561-I-3	Operating Gear Alignment . . . . .	I-12
561-I-4	Typical Connecting Rod Bearing Repairs . . . . .	I-14
561-I-5	Bushing Measurement Worksheet . . . . .	I-19
561-I-6	Pin Measurement Worksheet . . . . .	I-20
561-I-7	Final Bushing OD Machining Worksheet . . . . .	I-21
561-I-8	Typical Guide Piston Repairs . . . . .	I-26

**LIST OF ILLUSTRATIONS - Continued**

Figure	Title	Page
561-I-9	Guide Piston Measurement Worksheet . . . . .	I-31
561-I-10	Typical Fairwater Diving Plane Stock Bearing Repairs . . . . .	I-37
561-I-11	Bearing/Bushing Assembly (SSN 688 Class Shown) . . . . .	I-40
561-I-12	Bearing Measurement Worksheet . . . . .	I-43
561-I-13	Typical Stern Diving Plane Stock Bearing Repairs . . . . .	I-45
561-I-14	Bearing Measurement Worksheet . . . . .	I-49
561-I-15	Typical Stern Diving Plane Pintle Bearing Repair . . . . .	I-51
561-I-16	Bearing Measurement Worksheet . . . . .	I-55
561-I-17	Typical Rudder Bearing Repairs (Lower Rudder Shown) . . . . .	I-57
561-I-18	Bearing Measurement Worksheet . . . . .	I-62
561-J-1.	OUTBOARD CABLE INSULATION RESISTANCE vs TEMPERATURE (TYPICAL) . . . . .	J-2

**NOTE**

THIS CHAPTER HAS BEEN REFORMATTED FROM DOUBLE COLUMN TO SINGLE COLUMN TO SUPPORT THE NSTM DATABASE. THE CONTENT OF THIS CHAPTER HAS NOT BEEN CHANGED.

## CHAPTER 561

### SUBMARINE STEERING AND DIVING SYSTEMS

#### SECTION 1.

#### INTRODUCTION

##### 561-1.1 TYPES OF HYDRAULIC SYSTEMS

561-1.1.1 GENERAL. Submarine steering and diving control surfaces (rudder and diving planes) are positioned by means of mechanical linkage controlled by a hydraulic ram. The hydraulic systems used to operate the ram vary significantly among the different classes of submarines. Operational modes have been somewhat standardized, but the operating pressures, control types, and power sources have undergone considerable change and development. Submarine steering and diving hydraulic systems may be classified as variable or constant pressure systems.

561-1.1.2 VARIABLE PRESSURE SYSTEM (PRESSURE DEMAND). A variable pressure system is essentially a type of pump system that requires a separate pumping plant for each control surface. Because the load determines the operating pressure, this system is commonly referred to among submarine personnel as the pressure-demand system. The pressure developed by the pump is only that required by the load itself and any pressure loss in the system. Therefore, with this type of system, the operating pressure varies as a function of ship speed and control surface position. Both variable-volume and constant-volume pumps have been used for the independent power plants that must be used in a pressure-demand system. Although the use of reversible, variable-volume pumps has many advantages, the constant-volume screw pump is usually selected on the basis of its quieter operation.

561-1.1.3 CONSTANT-PRESSURE SYSTEM. In a constant-pressure system, an accumulator is usually employed to establish system pressure. The system pressure is directly determined by the air charge placed on the accumulator. The pump discharges to the system at this pressure regardless of the pressure required to move the load. Pressure in excess of that required to move the ram is dissipated by throttling the oil flow through directional and flow-control valves. An unloading valve is usually provided to bypass pump discharge to the tank at low pressure during periods when no ram movement is required. During these periods, the accumulator maintains the system at high pressure. With the constant-pressure type of hydraulic system, the power source may be either an independent power plant or one of the ship's hydraulic systems.

##### 561-1.2 POWER SOURCES AND MODES OF OPERATION

561-1.2.1 All steering and diving systems have more than one power source so that in the event of a failure an alternative means of control is available. The power source for all operational modes is given by ship class in [Table 561-1-1](#). To transfer from one power source to another generally requires transferring from one mode of operation to another mode. All submarines have at least three modes of operation, generally designated Normal, Emergency, and Hand (or Local). Most recently constructed ships also have an automatic control mode which is discussed in [paragraph 561-1.4](#). Operational characteristics are as follows.

561-1.2.2 The usual operating mode is normal mode. The mode of operation used when normal mode fails is emergency.

561-1.2.3 In the hand or local mode of operation, the hydraulic power source is usually a manually powered pump. On the fleet submarine, the hand mode of operation was used to provide silent operation as well as an alternative means of control in the event that both normal and emergency modes were inoperative. Starting with SS 580 Class, hand operation has been installed only as a means of positioning the control surfaces after the failure of both normal and emergency modes of operation. The hand pumps are installed near the rams rather than in the control room. Positioning of the control surfaces on these ships is slow (due to large capacity rams), and is normally used only to center (zero angle) the control surface. To control the ship with hand operation is most difficult even with a substantial reduction in ship speed. On some of the older ship classes, such as SSN 594, SSBN 608, and SSBN 616, local dc-powered vane pumps were installed in lieu of hand pumps. These battery powered pumps were capable of moving the control surfaces at 1/3 to 1/2 degree per second at forward ship speeds of approximately 6 knots.

561-1.2.4 In conjunction with local control, many submarines also have the capability to align the hydraulic system in such a manner that the control surfaces can be powered by the main or vital hydraulic system through the local hydraulic control valve. Starting with the SSN 688 Class, the handpumps were deleted and local control consisted of a local hydraulic control valve, with the ship's service hydraulic system as the power source.

561-1.2.5 Along with the conventional emergency control mode, SSN 688 Class, and TRIDENT are provided with a stored-energy system for the stern diving planes. The system consists of accumulators dedicated to the task of powering the planes 1-1/2 cycles in the event of failure of both normal and emergency power sources. Stern plane movement, when using stored energy, is controlled by means of the emergency control valve. The SSN 688 Class stored energy system differed from the TRIDENT system by using a floating piston accumulator. If one of the piston seals failed, air on one side of the accumulator piston could get into the hydraulic system, which would cause dieseling in the stern planes hydraulic system. For this reason the stored energy system was de-activated and eventually removed from the SSN 688 Class ships.

### **561-1.3 TYPES OF MANUAL CONTROL**

561-1.3.1 **RATE CONTROL.** In steering and diving systems that employ rate control, the direction of the control surface movement is determined by the direction in which the control wheel or stick is removed from the neutral position. The rate at which the control surface moves is determined by the amount the control wheel or stick is displaced from the neutral position. To stop control surface motion, the control wheel or stick must be returned to the neutral position. The control stick is normally spring-centered to the neutral position so that the operator need only release the control to stop the control surface movement.

561-1.3.2 **POSITION CONTROL.** With position control, the position to which the operator moves the control wheel or stick determines the angle ordered and transmits an input signal to a summing unit of a servo system. The actual position of the control surface determines a feedback signal that is also transmitted to the summing unit. In the summing unit the feedback signal is subtracted from the input signal. The difference is the error signal, which actuates the servo control valve for the system. When the control surface reaches the ordered position, the feedback signal equals the input signal. The error signal is then zero and movement of the control surface is stopped.

561-1.3.2.1 Prior to SSN 688 Class, position control and rate control generally were used for normal and emergency modes of operation, respectively. SSN 688 Class and TRIDENT Class use position control for both normal and emergency modes of operation. Normal control basically consists of an electro-hydraulic servo control system, whereas, emergency control is a mechanical-hydraulic equivalent of the normal mode system.

## 561-1.4 AUTOMATIC MODES OF CONTROL

561-1.4.1 GENERAL. Generally, all nuclear submarines have had an additional operating mode referred to as automatic. Many variations of this basic concept have been installed. In each, the hydraulic rams are controlled by means of the normal-mode hydraulic servo valve and the normal power source; however, the input to the servo valve does not originate at the control stick. Basic automatic control systems are discussed herein, but many of the initial installations have been removed and replaced as a result of obsolescence and high maintenance costs.

**Table 561-1-1. HYDRAULIC POWER SOURCES FOR STEERING AND DIVING**

Ship Class	Normal	Emergency**	Hand or Local Control
SSN 637 Class SSN 642	Main Hyd Sys	Vital Hyd Sys**	Local Control - Main Hyd Sys & Handpump
SSN 688 Class Fairwater Diving	Stbd Hyd Sys	Port Hyd Sys	Stbd Hyd Sys
SSN 688 Class Steering	Combined Steering & Stern Diving Power Plant	Port Hyd Sys	Stbd Hyd Sys
SSN 688 Stern Diving		Stbd Hyd Sys	Port Hyd Sys
SSBN 726 Class			
Fairwater Diving Steering Stern Diving	Stbd Hyd Sys Port Hyd Sys Independent Hyd Power Plant	Port Hyd Sys Stbd Hyd Sys Port Hyd Sys	Stbd Hyd Sys Port Hyd Sys Stbd Hyd Sys
SSN 21 Class			
Stern Planes (Inner) Stern Planes (Outer) Steering Bow Planes	Stbd Hyd Sys Stbd Hyd Sys Port Hyd Sys Port Hyd Sys	Port Hyd Sys Port Hyd Sys Stbd Hyd Sys Stbd Hyd Sys	Stbd Hyd Sys Stbd Hyd Sys Port Hyd Sys Port Hyd Sys
SSN 774 Class			
Stern Planes (Inner) Stern Planes (Outer) Steering Bow Planes	Stbd Hyd Sys Port Hyd Sys Port Hyd Sys Stbd Hyd Sys	Port Hyd Sys Stbd Hyd Sys Stbd Hyd Sys Stbd Hyd Sys	Port Hyd Sys Stbd Hyd Sys Stbd Hyd Sys Port Hyd Sys

\*\*Rate Control (Except SSN 688 Class and TRIDENT)

561-1.4.2 AUTOMATIC STEERING CONTROL. An automatic Course Keeping Control (CKC) system was installed on most early nuclear submarines. For both surface and submerged operations, emphasis was placed on accurately holding a course under varying speed and weather conditions. In the CKC mode of operation, if the submarine deviated from an ordered course because of uncontrollable external forces, a signal was induced by movement of synchros associated with the compass and heading (course order transmitter). This error signal, amplified by magnetic or solid state amplifiers, controlled the rudder servo valve that positioned the rudder so as to return the ship to the ordered heading. This system continued to operate and hold a fixed heading until the control station called for a new course. On many of the more recently constructed ships, an Automatic Course Control (ACC) system is installed. This system, in addition to maintaining a heading, is capable of making course changes automatically when the course order transmitter is manually changed.

561-1.4.3 AUTOMATIC DEPTH CONTROL. An automatic Depth Keeping Control (DKC) system was installed on most early nuclear submarines. It is similar, with respect to both components and operation, to the

CKC system, except that the error signal results from the variance between the depth registered by the ship's depth detector system and the ordered depth. Signal feedback for control action is from stern diving and fairwater planes. As the equipment limits the depth error signal, only small depth alterations can be made, enabling depth keeping but not significant depth change. More recent ships have an Automatic Depth Control (ADC) system that, in addition to maintaining constant depth, permits automatic compliance with any magnitude of depth change ordered.

**561-1.4.4 COMBINED AUTOMATIC STEERING AND DIVING.** Controllers combining the features of ACC and ADC are installed on the latest submarines.

**561-1.4.4.1 Controller Operation.** The controllers, referred to as Automatic Maneuvering Control (AMC), Automatic Submarine Control (ASC), provide automatic control of the ship. Desired depth and course data are manually dialed into the controller, which provides control signals (similar to ACC and ADC units) to bring the ship to the ordered course and depth.

## **561-1.5 SYSTEM OPERATING PRESSURE**

**561-1.5.1** As the size and speed of submarines have increased, the operating pressures of the steering and diving systems have increased correspondingly. On fleet submarines, systems have varied from 600 to 1,200 pounds per square inch (lb/in<sup>2</sup>). The independent steering and diving systems on later submarines operate at pressures of 1,500 to 3,000 lb/in<sup>2</sup>. As torque loads have increased with larger ships and higher speeds, 3,000-lb/in<sup>2</sup> systems have been used almost exclusively.

## **561-1.6 TYPICAL DIVING CONTROL SYSTEM**

**561-1.6.1** A typical stern plane hydraulic control system is shown in [Figure 561-1-1](#). The figure incorporates a simplified electrical block diagram to show the relationship of components. The block labeled function generator primarily represents the electrical equipment associated with the automatic ship control feature. Fairwater diving and steering circuits are similar. [Figure 561-1-2](#) shows a typical stern arrangement for SSN 688 and TRIDENT Class ships, except for SSN 718, which has split stern plane, which is shown in [Figure 561-1-3](#). For specific information pertaining to hydraulic systems and electrical controls refer to the applicable Ship Systems Manual (SSM), (i.e. NAVSEA No. S9SSN-W4-SSM-DAO/(U)688CLV3P2C1 STEERING AND DIVING CONTROL SYSTEM for SSN 688 Class ships).

**561-1.6.1.1** For information on SSN 688 Class Retractable Bow Planes (RBP) refer to NAVSEA S9561-BC-MAN-020 Steering and Diving Control Systems in SSN 688 Class Submarine Retractable Bow Planes.



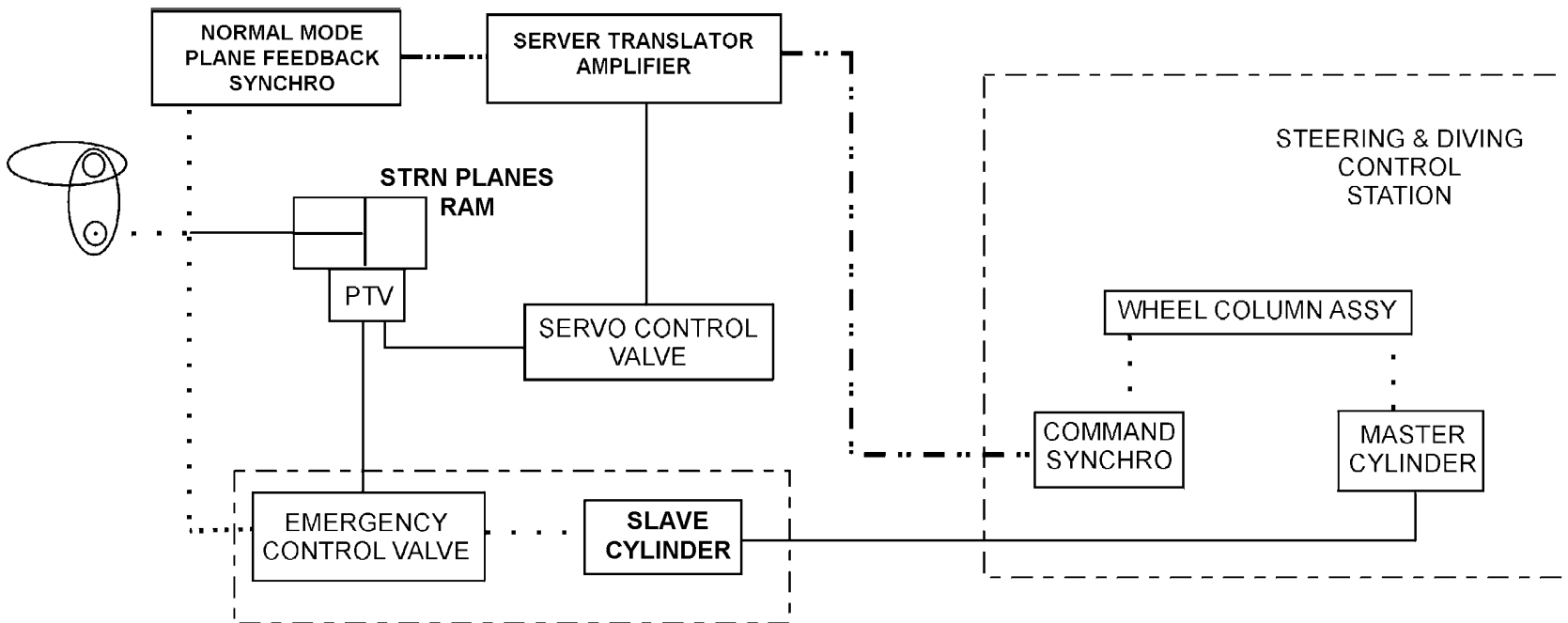

- ..... MECHANICAL LINKAGE
- HYDRAULIC LINES
- - - - - ELECTRONIC SIGNALS

Figure 561-1-1. Typical Stern Diving Control System Simplified Block Diagram (Sheet 1 of 2)



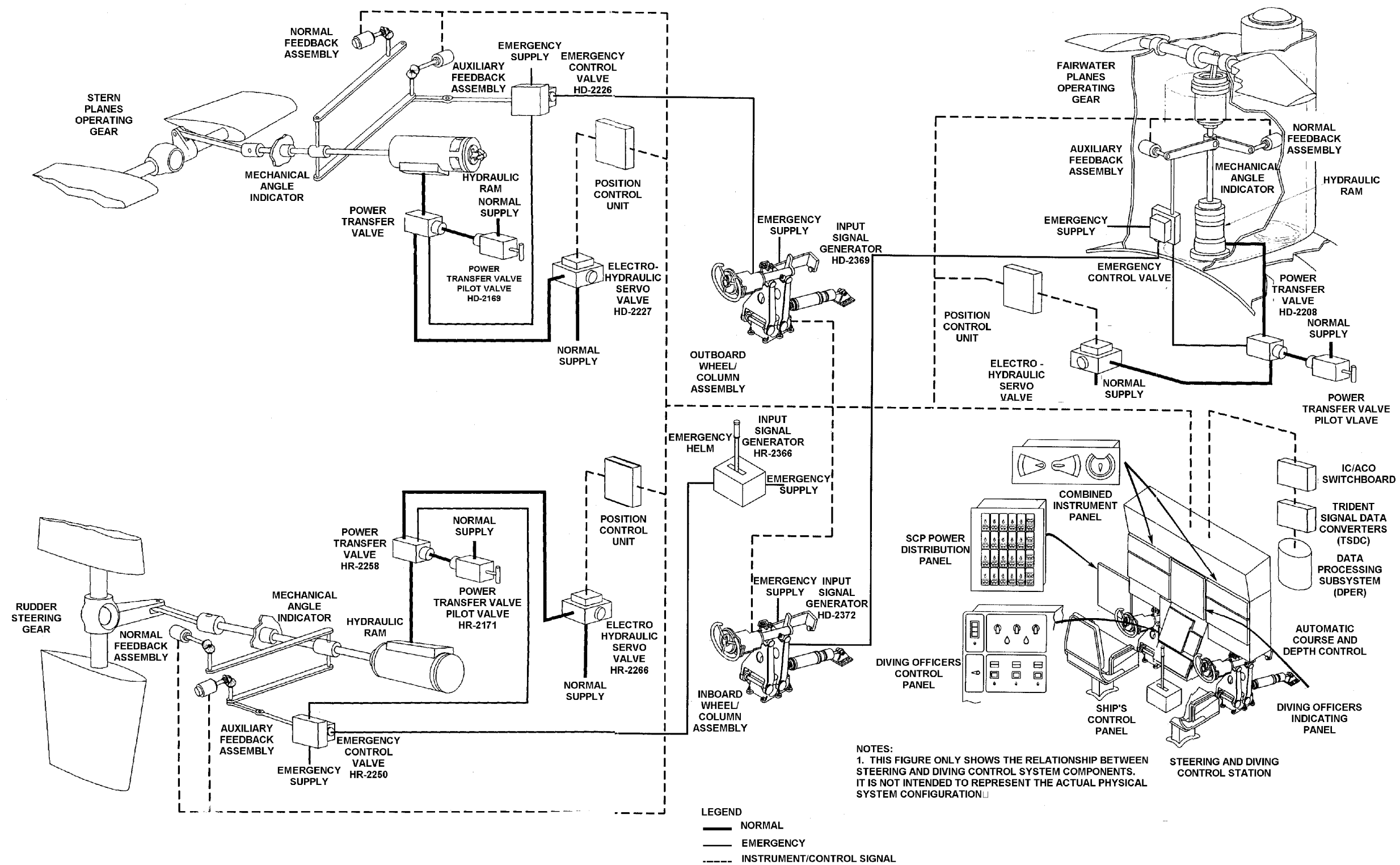

Figure 561-1-1. Typical Stern Diving Control System Simplified Block Diagram (Sheet 2 of 2)





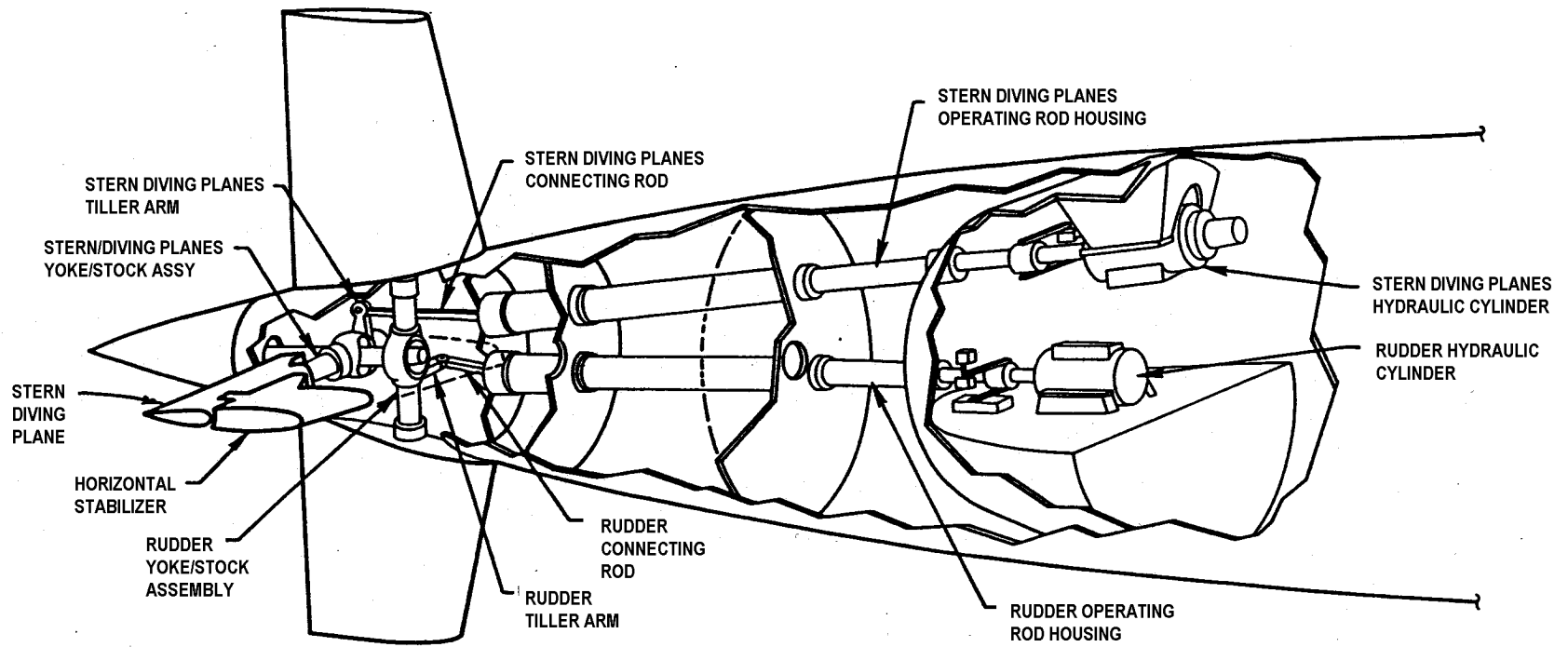

Figure 561-1.2 Typical Stern Arrangement for SSN 688 Class

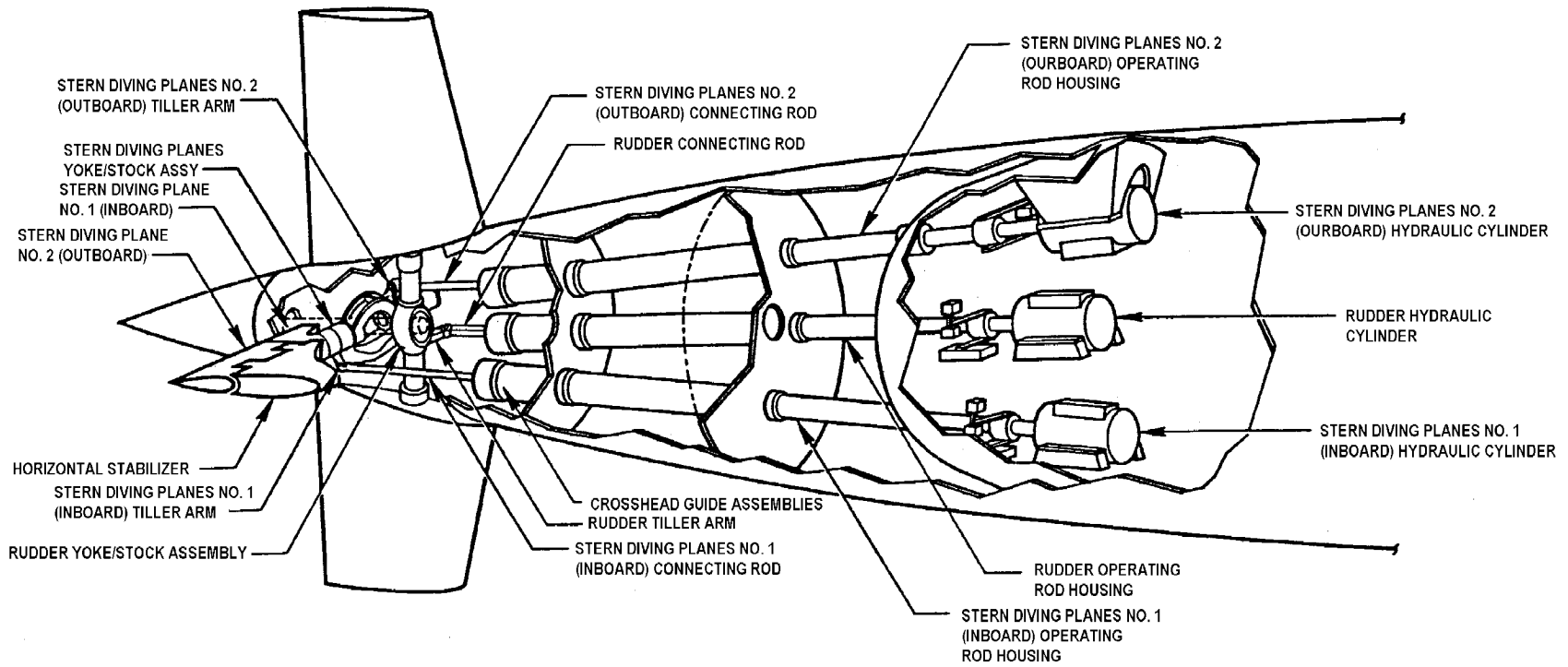

Figure 561-1-3 Stern Arrangement for SSN 718 with Split Stern Planes

**SECTION 2.**  
**COMPONENTS: FUNCTION AND MAINTENANCE**

**561-2.1 CONTROL STATION COMPONENTS**

561-2.1.1 GENERAL. Most submarine steering and diving control stations consist of an inboard and outboard operating station facing the ship control panel. Principal controls and indicators that are mounted on the ship control panel at a typical steering and diving control station are illustrated in [Figure 561-2-1](#). Each operating station has an aircraft-type control column. Each wheel/column assembly consists of a control column, a wheel mounted on the control column, positioning devices, and three synchro resolvers.



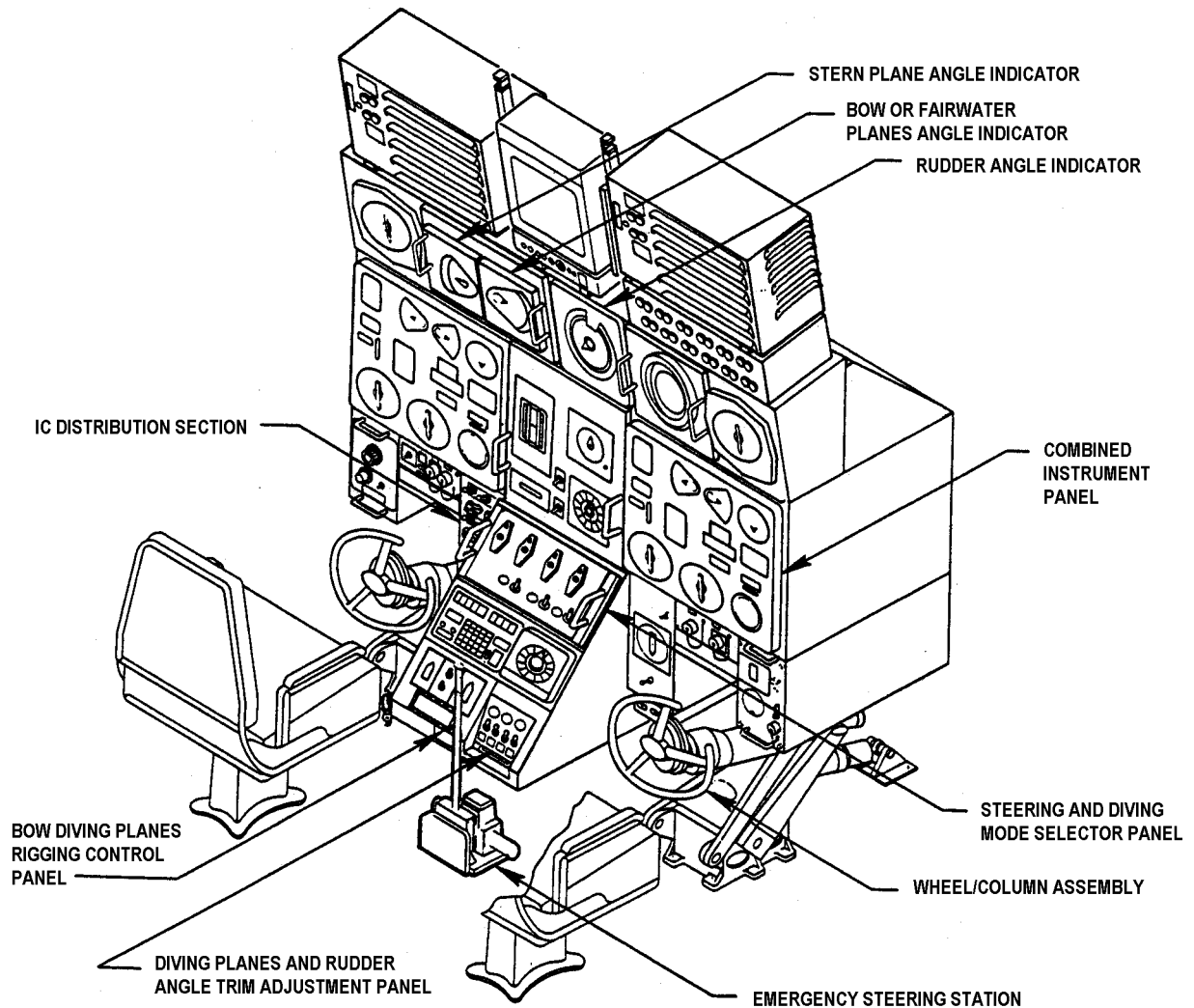

Figure 561-2-1. Typical Steering and Diving Control Station

561-2.1.2 WHEEL/COLUMN ASSEMBLIES. Stern diving planes and fairwater diving planes are controlled in both normal and emergency modes by fore-and-aft movement of the control columns. Pushing the control columns forward moves the planes in the dive direction. Pulling the controls aft moves the planes in the rise direction. Control column movement is limited to approximately 6 inches of travel forward (hard dive) or aft (hard rise) from its center position. Adjustable hard stops are provided at the full throw positions. These stops are used for initial system alignment by setting the maximum rise and dive angles for diving planes in the normal control mode.

561-2.1.2.1 Each control column is spring-loaded to provide a reactive force against movement by its operator. When the controls are released, spring action returns the control column to its center position. The force required to move a control forward or aft is nominally 10 pounds at center position, increasing to 20 pounds at full throw, and is adjustable.

561-2.1.2.2 Movement of the control column, which is pivoted at the base of the assembly, operates a gear train that rotates two synchro resolvers. Each synchro resolver, when energized, provides an electrical input signal to a servo translator amplifier. By switching arrangement, either the stern plane or fairwater plane translator servo amplifier, or both, may be connected to the synchro resolvers of either the inboard or outboard control column.

561-2.1.2.3 Each control column can be immobilized in one position by a pin-type lock. When secured with the lock, the control column is positioned for slight rise angle. This angle is determined for each ship during sea trials. To attain minimum drag on the hull during surface operation, the stern planes must be in the position that results from this ship-specific rise angle.

561-2.1.2.4 Emergency control-mode operation of stern diving planes and fairwater diving planes is controlled from the outboard and inboard wheel/column assemblies, respectively. Emergency control of the diving planes cannot be switched from one wheel/column assembly to the other. The outboard wheel/column assembly is mechanically linked to the emergency control valve for the stern diving planes. The inboard wheel/column assembly is mechanically linked to the emergency control valve for the fairwater diving planes.

561-2.1.2.5 Rudder surfaces are normally controlled by rotation of the wheel on either one or the other (but not both) of the column assemblies. For each 3-1/2 degrees of wheel rotation, the rudder moves 1 degree. Clockwise wheel rotation results in a right rudder movement; counterclockwise rotation produces a left rudder movement.

561-2.1.2.6 When rotated by the operator, the wheel positions a synchro resolver, which in turn generates an input signal for the rudder translator servo amplifier. By switching arrangement, the rudder translator servo amplifier may be selectively connected to the synchro resolver of either the inboard or outboard wheel. The wheel can be locked in its neutral position by a pin-type lock. Also, a drag force may be set on the wheel in any position from zero to lock. The drag force is adjusted by the rotation of a plate below the wheel; counterclockwise rotation increases the drag. Rotation of the drag plate sets a disc-type brake. The braking force is provided by a belleville washer. On the wheel shaft is a rack-operated stop and neutral detent device. The rack is spring-loaded to return the wheel to its neutral position (zero rudder angle), indicated by a spring-actuated detent. The force required to rotate the wheel, as measured tangentially at the rim, is nominally 1 pound at the center position, increasing to 5 pounds at maximum range of rotation. Also, adjustable hard stops are provided to limit movement of the rack, which in turn limits rotation of the wheel. These stops are used to align the system initially by setting the maximum right and left rudder angle in the normal control mode.

561-2.1.2.7 In the normal control mode, the diving planes and the rudder can be operated from either the inboard or outboard wheel/column assembly, as selected by the position of a selector switch (or switches) located on the ship's control panel.

561-2.1.3 EMERGENCY STEERING STICK. Emergency rudder operation is accomplished by manually positioning the rudder emergency control valve using the emergency steering stick located at the ship control station. The stick is spring-loaded so that, if released, it will return to the neutral, rudder-amidship position.

561-2.1.4 CONTROL COLUMN MAINTENANCE. With the original design control column on SSN 642, it was possible to incorrectly assemble the pinion cam in an upside-down position. As a result of incorrect assembly, the stick could jam affecting both normal and emergency modes of operation for that stick. SHIPALT SSBN 1287 was later authorized to prevent improper assembly of the pinion cam. When maintenance action is required on the control column assembly, the most important thing to remember is that the column is within the SUBSAFE boundary and a Re-Entry Control (REC) package is required to perform the work. The use of the REC package, if properly performed, will ensure proper assembly of the control column in accordance with the applicable drawings.

## 561-2.2 SYNCHRO RESOLVERS

561-2.2.1 Basically, a synchro resolver (or control transformer) consists of a concentrically-aligned wound rotor and stator that convert a mechanical position (angular rotation of the rotor shaft) into an output electrical signal by producing a variable magnetic coupling with the stator windings. The output voltage varies sinusoidally with the rotor position when the stator is excited. Shipboard use of synchro resolvers is described in paragraphs [561-2.2.2](#) and [561-2.2.3](#).

561-2.2.2 The steering and diving system generally uses nine synchro resolvers (transformers) that generate electrical signals for processing by the normal control mode circuitry. Six of the synchro resolvers are used to generate ordered rudder, stern plane, and fairwater plane angle signals; the remaining three are used to generate actual rudder, stern plane, and fairwater plane feedback signals. A limited number of ships have systems in which a common synchro resolver is used to generate ordered signals for the fairwater and stern planes. The total number of synchros on these ships is seven; four are for ordering signals and three are for feedback signals.

561-2.2.3 Synchro resolvers used in the steering and diving systems are not considered repairable by ship's force and should be replaced if they malfunction. The only tests that can be performed to troubleshoot a synchro resolver suspected to be a problem component are resistance-to-ground and continuity tests of the stator windings. Additional information on synchro resolvers is presented in NSTM Chapter 430, Interior Communication Installations.

## 561-2.3 TRANSLATOR SERVO AMPLIFIERS

561-2.3.1 The command signal for each servo control valve torque motor is supplied by a translator servo amplifier. Each amplifier processes signals both from a control stick command synchro resolver at the control station and from a feedback synchro resolver located in the vicinity of the control surface operating cylinder. In addition, each amplifier produces an output signal that operates the torque motor in a servo control valve. Operational characteristics are described in paragraphs [561-2.3.2](#) through [561-2.3.7](#).

561-2.3.2 Translator servo amplifiers have changed extensively since the beginning of nuclear submarine construction. In addition to the basic function of processing signals to control the servo valve, most translator amplifiers perform the second function of providing an automatic means to shift to the emergency control mode in the event of certain system failures. This second function is performed by the fail-detect network.

561-2.3.3 On earlier classes, the fail-detect network only monitored the translator amplifier for proper operation (internal failures). Through evolution, the function of the fail-detect network has greatly expanded. On SSN 688 and TRIDENT Class ships, the fail-detect network will automatically transfer from the normal control mode to the emergency control mode upon detection of any of the following failures:

- a. Loss of electrical power to the amplifier
- b. Loss of synchro excitation voltage
- c. Failure in the amplifier network
- d. Control surface movement in a wrong direction
- e. Control surface movement at an improper rate
- f. Excessive steady-state error between the ordered and actual control surface position

g. Control surface movement when no error signal is present.

561-2.3.4 In the event of any of the aforementioned failures, the fail-detect channel will interrupt power to the solenoid of the power transfer valve pilot valve, causing it to shift to its emergency mode position.

561-2.3.5 The basic construction of these amplifiers has evolved from point-to-point wired magnetic amplifiers to solid-state amplifiers with plug-in modules.

561-2.3.6 Troubleshooting of all translator servo amplifiers, particularly older models, must be conducted cautiously. Improper technique can easily result in excessive damage. Damage to older amplifiers can be particularly expensive because of the high cost and scarcity of outdated components.

561-2.3.7 For detailed information and troubleshooting guidance, refer to applicable equipment technical manuals.

## **561-2.4 SERVO CONTROL VALVES**

561-2.4.1 GENERAL. Servo control valves installed in submarine steering and diving systems can be classified into two general types. The most common type is the electrohydraulic servo valve that is used to control normal mode steering and diving on all submarines. The other type of servo valve, the hydraulic-mechanical servo valve, is used for emergency steering and diving modes on SSN 688 and TRIDENT Class submarines.

561-2.4.2 ELECTROHYDRAULIC SERVO VALVES. The electrohydraulic servo valves used for steering and diving control are two-stage hydraulic control valves. An electrical input signal (the difference between command and feedback signals) results in a hydraulic flow output proportionate to the input signal.

561-2.4.2.1 SV-438-10P and SV-438-15P Servo Valves. SV-438-10P and SV-438-15P valves were originally designed and built by Sanders Associates but are now being overhauled by Sargent Controls Inc. The SV-438-10P valves were installed on the early SSN 637 Class submarines. The similar SV-438-15P valve is installed on SSN 678 through SSN 687. Five different configuration SV-438-10P valves were originally procured to match five existing electrical control interfaces. Subsequently, minor technical problems resulted in changes known as the viscous damper modification and the open orifice modification. In addition, some amplifier design changes by Electric Boat Division have resulted in torque motor wiring changes and three more configurations. Specifics regarding the possible valve configurations are addressed in the applicable servo valve technical manual (see paragraph [561-2.4.6](#)).

561-2.4.2.1.1 The primary parts of the SV-438-10P and SV-438-15P low-noise electrohydraulic servo valves are shown in [Figure 561-2-2](#). An input signal is applied to the servo valve torque motor adapter (not shown) from the translator servo amplifier. The torque motor adapter is required to connect the amplifier to the servo valve torque motor (see paragraph [561-2.4.2.2](#)). The torque motor produces an output torque that is proportional to the input signal current. The torque tube displaces the flapper valve between the nozzles of the pilot stage. This displacement causes an unbalance in pressure between PV1 and PV2 that moves the main control spool off center. Movement of the main spool continues until the feedback spring (wand) between the main spool and the flapper produces a torque equal and opposite to that produced by the torque motor. The spool displacement is therefore proportional to the input signal current. Accordingly, flow through the valve is proportional to input signal up to the point of maximum spool displacement. The maximum flow rate and, consequently, the ram rate, can be con-

trolled either by setting the flow limiter adjustments to limit main spool travel or by limiting servo amplifier voltage output as discussed in paragraph 561-2.4.5.

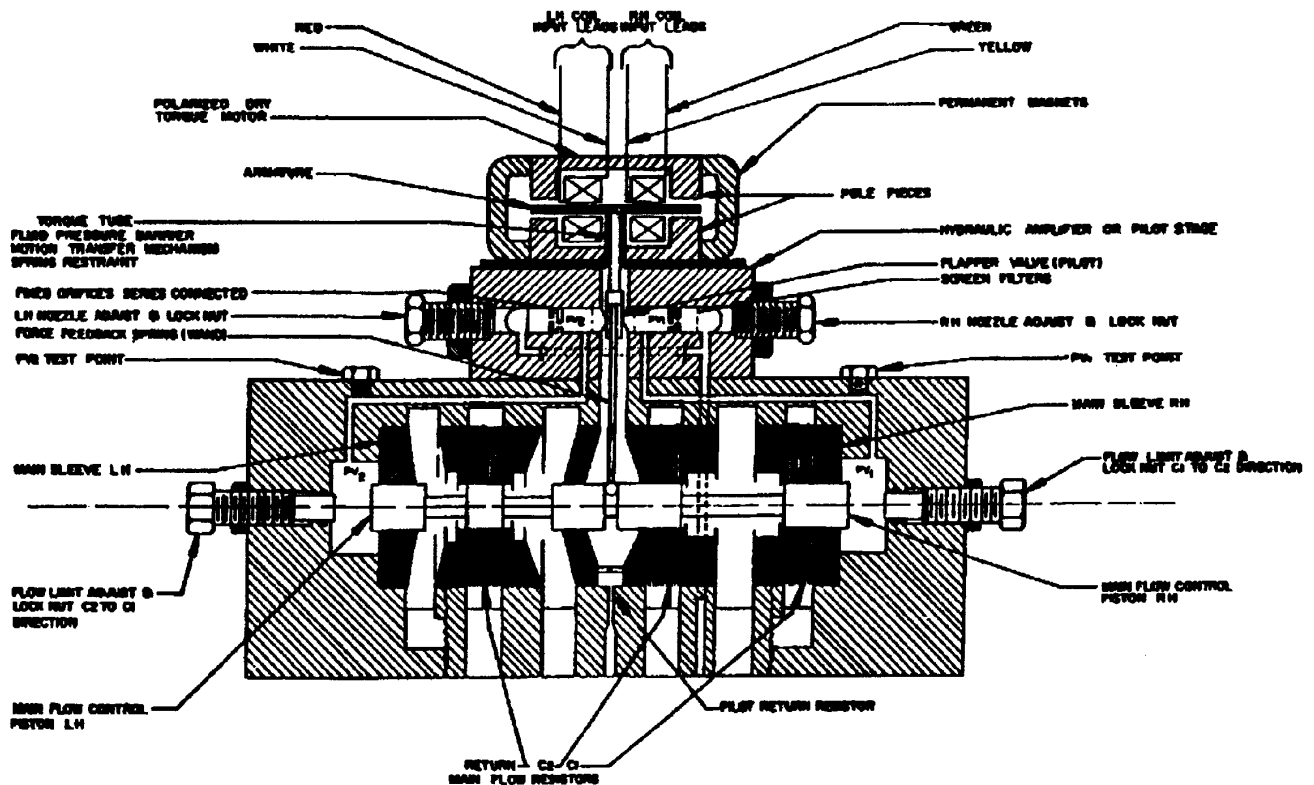

Figure 561-2-2. Servo Valve, Cross-Sectional View

### CAUTION

**Prior to the installation of a replacement servo valve, the valve shall be checked to ensure that the correct torque motor adapter is installed. Failure to use correct torque motor adapter may result in system malfunction.**

561-2.4.2.2 SV-438-10P Torque Motor Adapter. When initially installed, each SV-438-10P valve was procured with a torque motor adapter configuration to suit the ship's control system amplifier. Any SV-438-10P valve configuration may be installed on any ship with SV-438-10P valves by rewiring the torque motor adapter to suit the ship's control system. Torque motor adapter removal, rewiring, and replacement procedures for each ship installation are provided in the servo valve technical manual (see paragraph 561-2.4.4).

561-2.4.2.3 Electrohydraulic Servo Valve Null Adjustment. Servo valves may be null adjusted on a test stand or with the valve installed in the ship. Null adjustment procedures are provided in servo technical manuals (see paragraph 561-2.4.4).

561-2.4.2.4 Bendix Valves. Bendix Corporation has changed names several times and the name plates on the valves reflect these changes. Although the name plate may indicate Bendix Corporation, or Garrett Fluid Systems,

or AlliedSignal Corporation the valves are still supported by the same people, now Honeywell Corporation. Functional drawings of the Honeywell Corporation electrohydraulic servo valves used aboard the SSN 688 Class and TRIDENT Class ships are shown in [Figure 561-2-3](#) and [Figure 561-2-4](#) respectively.

561-2.4.2.4.1 In the SSN 688 Class valves, hydraulic operation of the first stage torque motor is achieved through the use of a flapper and two small nozzles. Hydraulic pilot pressure is applied to the two nozzle pressure chambers through a filter and two fixed orifices. When an input command signal is applied to the coils, the flapper moves from the null position, changing the gaps between the output ends of the two nozzles and the adjacent surfaces of the flapper. One gap is narrowed and the other is widened, resulting in an imbalance in nozzle chamber pressure. These pressure changes are transmitted to the second stage valve where they actuate the second stage valve spool. The drive piston receiving the higher pilot pressure begins to move the valve spool toward the opposite end and override the opposing centering-spring force, allowing spool movement. As the spool displaces from null system, hydraulic fluid is ported through the quieting elements in the sleeve. This allows system flow between the system hydraulic power source (ports P and R) and the associated ship's equipment (ports C1 and C2) being operated by the servo valve. The direction of flow is dependent on the polarity of the input command signal to the first-stage torque motor. The amount of spool travel, and hence the amount of fluid flow through the servo valve, is proportional to the amplitude of the input signal.

561-2.4.2.4.2 When the torque motor is at electrical null, the second-stage valve is at hydraulic null. All flow through the valve (ports P, R, C1, and C2) is blocked, except for allowable internal leakage. The second-stage valve spool is maintained at null (center position) by centering springs at each end and by balanced hydraulic pilot pressure applied to pressure chambers.

561-2.4.2.4.3 An adjustment nut and jamnut are installed at each end of the second-stage valve and used to null the valve spool with zero milliamperes of input current applied to the first-stage torque motor. The adjustment nut is used to position the associated drive cylinder inward or outward inside the bore of the end cap, increasing or decreasing centering spring tension on that end of the spool. A bolt threaded into the outboard end of each drive cylinder provides the means to adjust spool travel in each direction. A jamnut is installed on each bolt to lock the bolt at the selected position. By adjusting and locking the bolts, the flow rate through the servo valve is adjustable.

561-2.4.2.4.4 In the TRIDENT valves ([Figure 561-2-4](#)), the functioning of the first stage is the same as for the SSN 688 Class valves except that second stage spool positioning control is different.

561-2.4.2.4.5 Linear Variable Differential Transformers (LVDTs) (hereinafter referred to as transducers) threaded into the outboard end of each drive cylinder provide a means of sensing and controlling the valve spool position. Transducer output, resulting from valve spool motion in either direction, is fed to the ship system electronics where it is used to control the electrical command to the torque motor. The second-stage valve is operated by internal pilot differential pressures created by operation of the first-stage torque motor. When the torque motor is at electrical null, the second-stage valve is at hydraulic null, and the transducers are at electrical null, with all flow through the valve (ports P, R, C1, and C2) blocked. The second-stage valve spool is maintained at null (center position) by transducer feedback, by centering springs at each end, and by balanced hydraulic pilot pressure applied to pressure chambers in drive cylinders also located at each end.



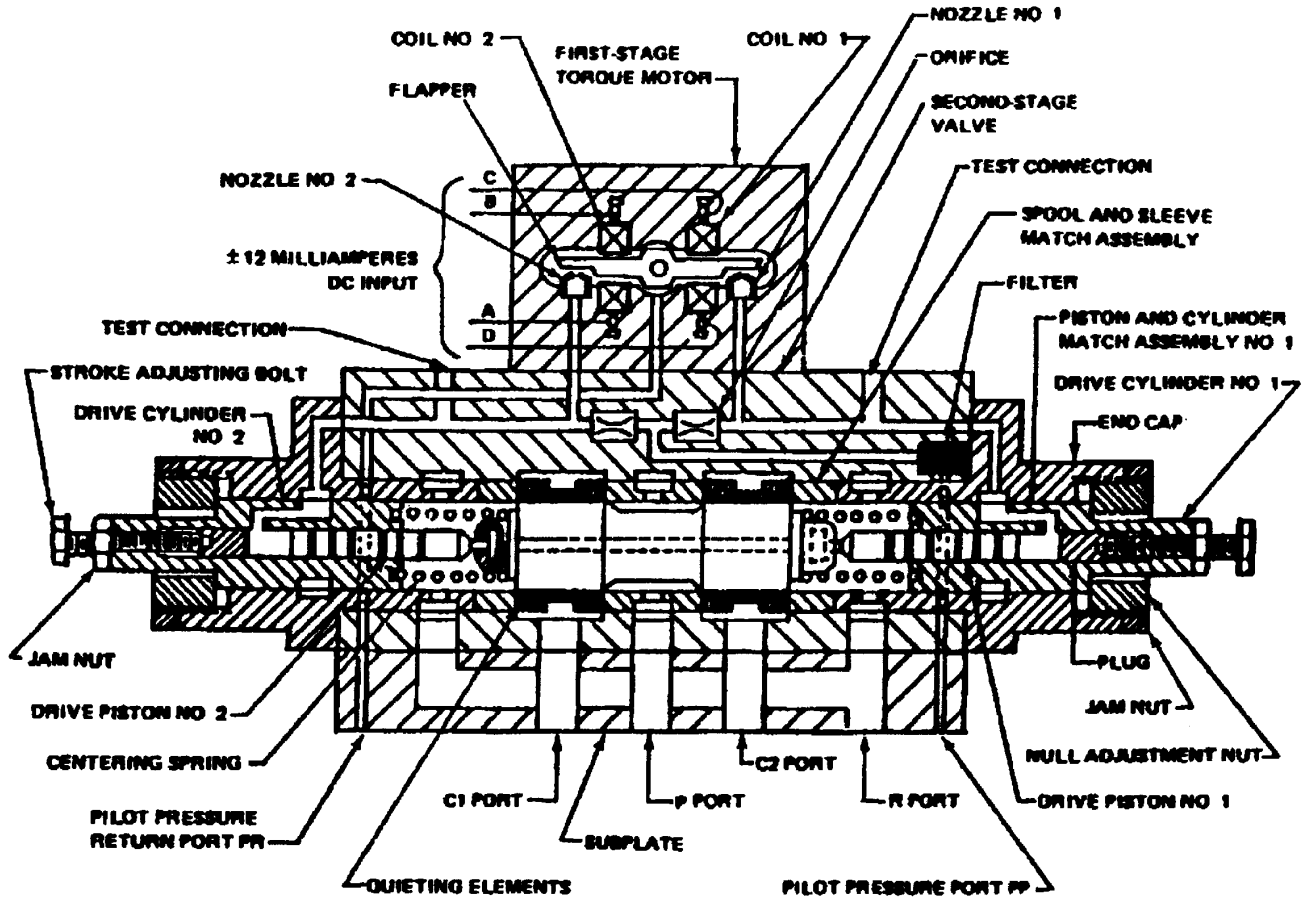

Figure 561-2-3. SSN 688 Servo Valve, Functional Diagram

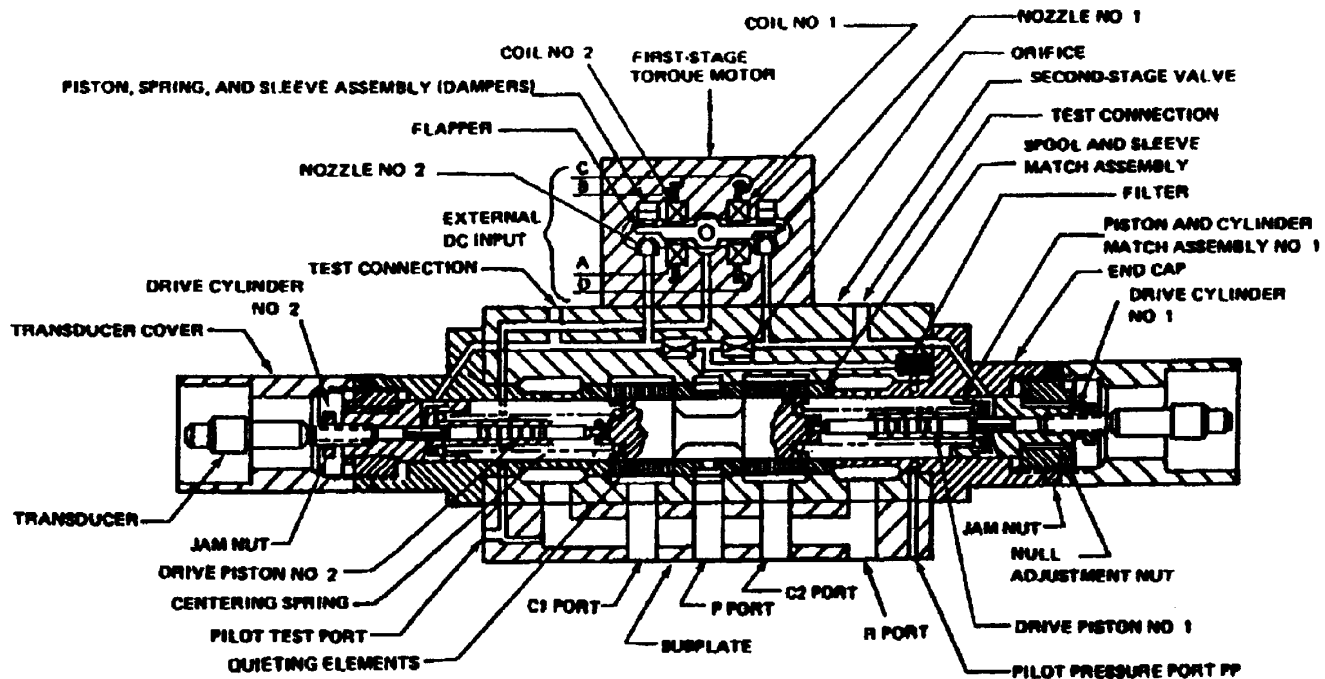

Figure 561-2-4. TRIDENT Class Servo Valve, Functional Diagram

561-2.4.2.4.6 When the first-stage torque motor receives an input command signal, the nozzle chamber pressures in the first stage become unbalanced. As a result, a pressure differential is created between the two drive-cylinder pressure chambers in the second-stage valve. The drive piston receiving the higher pilot pressure will begin to move the valve spool toward the opposite end where the pilot pressure is being ported to pilot pressure return through the first-stage torque motor nozzle block. The increased pressure in the small pressure chamber of the drive cylinder and drive piston also overrides the opposing centering-spring force, allowing spool movement. Spool movement causes transducer output to the ship's system in a feedback loop to control and maintain spool position to the commanded position. As the spool displaces from null, system hydraulic fluid is ported through the quieting elements in the sleeve. This allows system flow between the system hydraulic power source (ports P and R) and the associated ship's equipment (ports C1 and C2) being operated by the servo valve. The direction of flow is dependent on the polarity of the input command signal to the first-stage torque motor. The amount of spool travel is linearly proportional to the amplitude of the input signal, and flow through the valve is controlled electronically instead of by spool stops as discussed in the preceding description. An adjustment nut and jamnut are installed at each end of the second-stage valve and are used to null the valve spool with zero milliamperes of input current applied to the first-stage torque motor. The adjustment nut is used to position the associated drive cylinder inward or outward inside the bore of the end cap, increasing or decreasing centering spring tension on that end of the spool. It must be clearly realized that this adjustment is a null adjustment only and not a spool stop to limit maximum flow through the servo valve.

561-2.4.3 MECHANICAL-HYDRAULIC SERVO VALVE. The mechanical-hydraulic servo valve receives input through hydraulic lines. In SSN 688 Class, a master cylinder is moved by the control column or wheel proportional to the ordered control surface position. Fluid from the master cylinder, in turn, moves the slave cylinder at the servo valve commensurate with the ordered control surface position. In the TRIDENT valve, the procedure is similar except that the slave cylinder displacement is dependent upon a pressure signal that is proportional to the displacement of a pilot valve at the control station. In both SSN 688 and TRIDENT Classes,



there is mechanical feedback input to the valve as the control surface moves to its ordered position. The summing linkage at the valve returns the emergency control valve spool to the blocked neutral position when the control surface reaches the ordered angle.

561-2.4.3.1 SSN 688 Class - Bendix (Honeywell Corporation) Mechanical-Hydraulic Servo Valve. A schematic of the SSN 688 Class mechanical-hydraulic servo system is shown in [Figure 561-2-5](#). Movement of the control column or stick produces a mechanical input signal by positioning the master cylinder piston. The position of the master cylinder piston is always proportional to the ordered control surface position. The master cylinder piston displacement causes a hydraulic fluid displacement that is transmitted via piping to the slave cylinder in the emergency control unit assembly. This displacement of the slave cylinder causes the pilot and main stage spools of the emergency control valve to shift, porting pressure to the control surface operating cylinder. As the control surface moves, the emergency follow up and transmitter drive linkage attached to the operating rod coupling is driven. The feedback linkage transmits a mechanical signal to the emergency control unit assembly, which causes the emergency control valve spool to return to the blocked center position when the control surface reaches the ordered angle. As long as the control column is held at the ordered position, the control surface will also hold its respective position. With this system, control surface movement rate is maintained by a pressure-compensated flow-control valve located in the return line from the emergency control valve.

561-2.4.3.2 TRIDENT Class - Sargent Mechanical-Hydraulic Servo Valve. A schematic of the TRIDENT Class mechanical-hydraulic servo system is shown in [Figure 561-2-6](#).

561-2.4.3.2.1 Each control surface control system input signal generator consists of two three-way, infinite positioning, proportional control valves within a common body. The valves are operated in conjunction with each other by the control column or emergency helm. When a control column or the emergency helm is deflected, the spools of both valves in the input signal generator are displaced from the blocked center position. One of the spools is positioned to allow pressurized hydraulic fluid to be supplied to the slave cylinder of the emergency control valve, while the other spool is positioned to vent fluid from the opposite end of the slave cylinder.

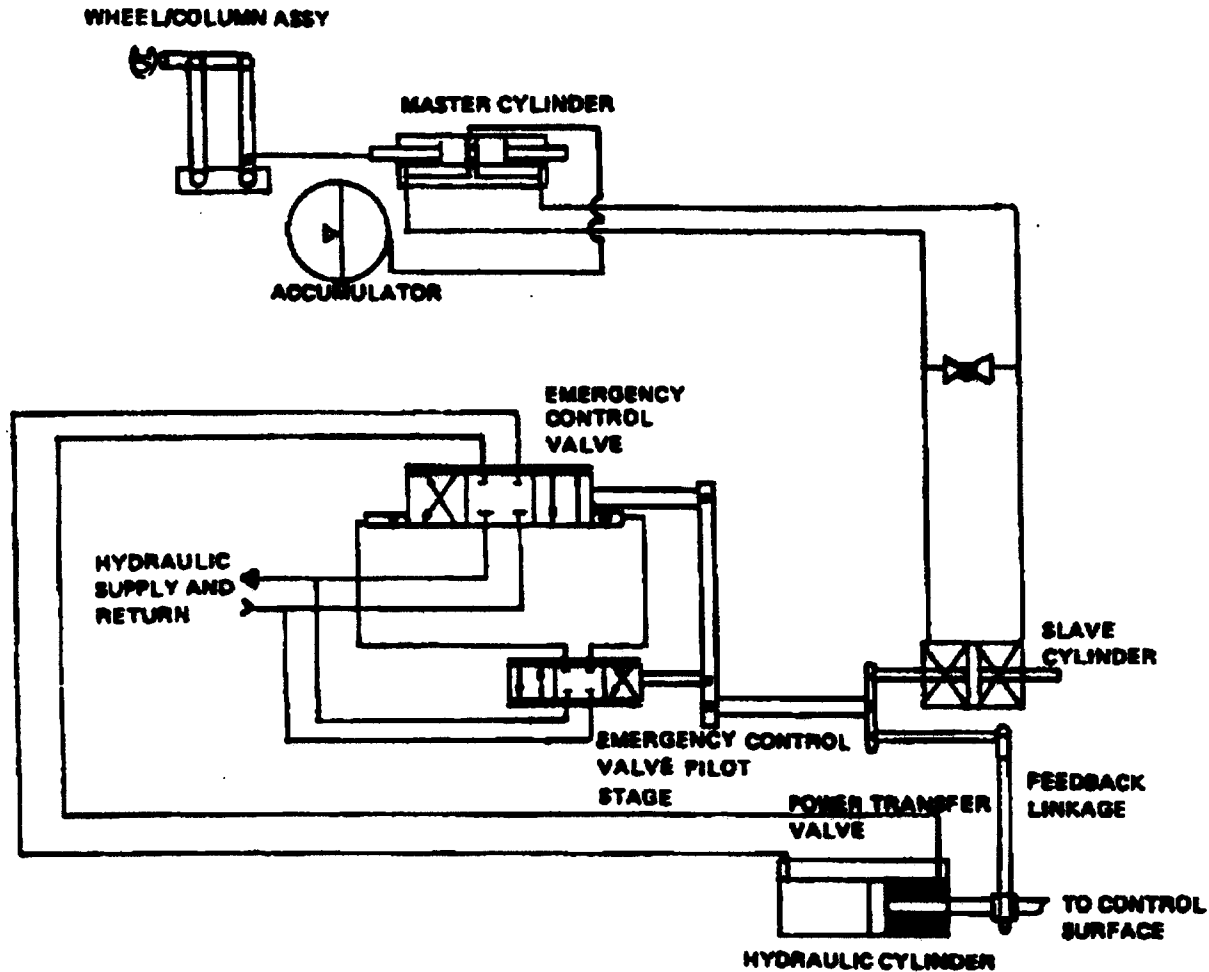

Figure 561-2-5. SSN 688 Class Mechanical-Hydraulic Servo System (Emergency Mode)

561-2.4.3.2.2 The spool of each valve in the input signal generator is spring-loaded on one end and has a hydraulic pilot actuator on the opposite end. The interaction of the spring and the hydraulic pressure on the pilot actuator causes the valves to remain open only until the hydraulic pressure balances the spring pressure applied when the control or emergency helm is deflected. This hydraulic fluid pressure is the control surface hydraulic position command signal sent to the emergency control valve.

561-2.4.3.2.3 The emergency control valve assembly consists of a slave cylinder, two directional control valves, a boost cylinder with associated cross-port relief valve, and the interconnecting summing linkage. The hydraulic input signal to the emergency control valve is applied to the slave cylinder. Displacement of the slave cylinder piston causes the movement of the summing linkage input arm to shift the pilot valve spool.

561-2.4.3.2.4 Hydraulic fluid is ported through the pilot valve to the boost cylinder, causing movement of the piston (which is pinned to both the input arm and the feedback arm of the summing linkage). Movement of the piston in the boost cylinder causes displacement of both the input arm and the feedback arm. When the piston of the boost cylinder reaches a position corresponding to the desired control surface angle, the pilot valve spool will be at the blocked center position, thus holding the piston of the boost cylinder at the desired position. At the same time, displacement of the feedback arm (connected to the opposite end of the boost cylinder piston) causes the main stage spool to be positioned so as to allow pressurized hydraulic fluid to be supplied to the control surface ram via the power transfer valve. As the control surface ram moves, the feedback arm is displaced, thus returning the main stage spool to the blocked center position. When the ram reaches the desired position, the main

stage spool is at the blocked position; and ram motion stops. With this system, control surface movement rate is controlled by adjustable mechanical stops on the main stage spool extension.

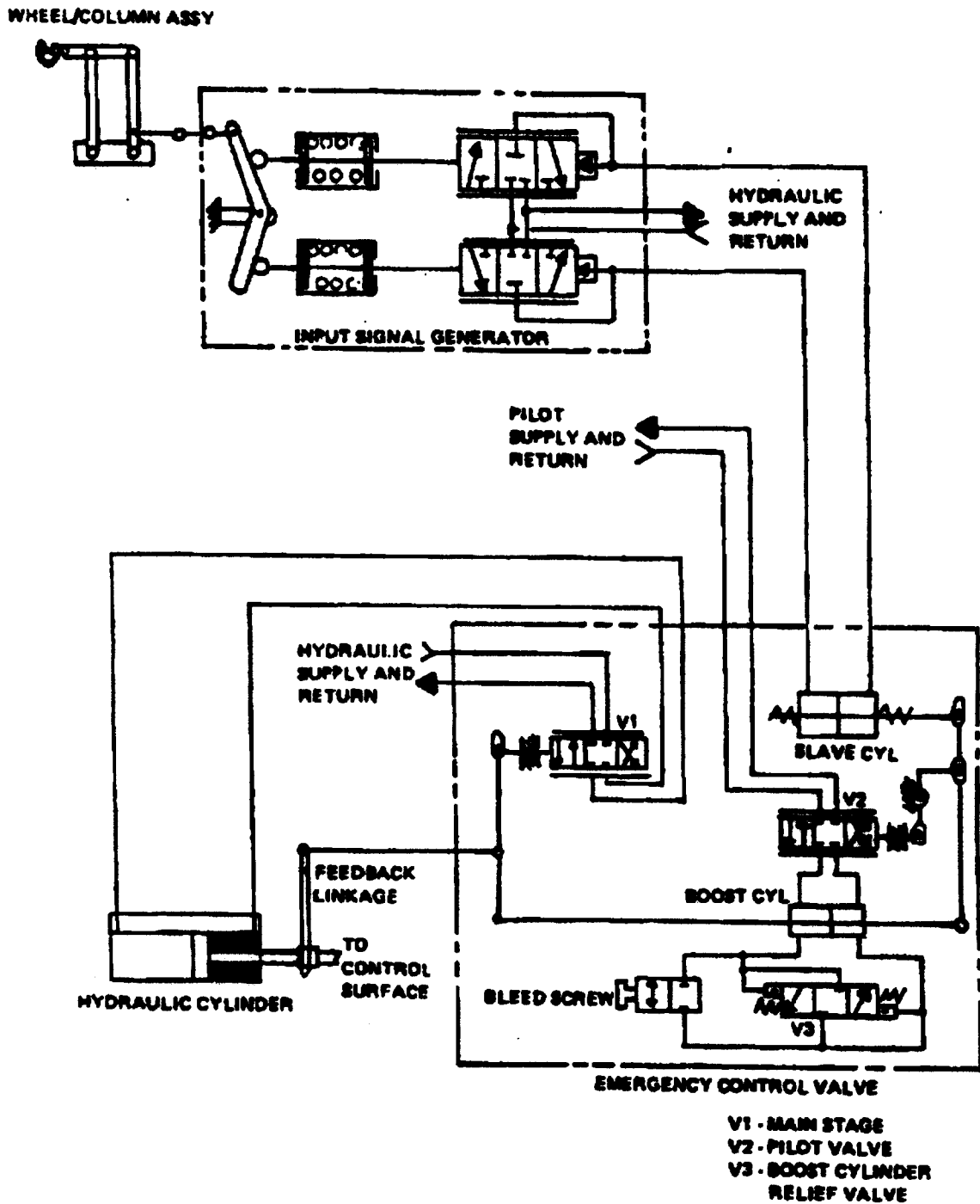

Figure 561-2-6. TRIDENT Class Mechanical-Hydraulic Servo System (Emergency Mode)

561-2.4.4 REFERENCE MANUALS. Each model servo valve installed in submarine steering and diving systems has an individual technical manual. The servo valve model installed in each ship or ship class, along with its corresponding technical manual number, is identified in Table 561-2-1. Applicability of manuals should always be verified using the most current ships' technical manual index.

**Table 561-2-1 SERVO VALVE APPLICABILITY**

Ship Number	Manufacturer and Manufacturer's Part Number	NAVSEA Technical Manual Number
AGSS 555	Arkwin 7A 038	0322-LP-037-5010
SS 642	Sargent Industries* SV-438-10P	S9561-AQ-MMA-010
SSN 678-687	Sargent Industries* SV-438-15P	0922-LP-030-4010
SSN 688 Class Normal Mode	Bendix Electrodynamics 3188615-1 (Honeywell Corporation)	0948-LP-035-9010
SSN 688 Class Emergency Mode	Bendix Electrodynamics 3188610 (Honeywell Corporation)	0948-LP-113-4010
SSBN 726 Class Normal Mode	Bendix Electrodynamics 3311731 (Honeywell Corporation)	S6435-AB-MMA-010
SSBN 726 Class Emergency Mode	Sargent Controls 20455-001	** SVTM 13-9-12
SSN 21 Class Normal Mode	Honeywell Corp. 3798354	** SVTM 6-24-1
SSN 21 Class Emergency Mode	Honeywell Corp. 3798710	** SVTM 13-14-19
SSN 774 Class	Sargent Controls (Strn & Bow Plns) 52120-001	** TBD
	Honeywell Corp. (Rudder) 3798354	SVTM 6-24-1

\*Originally manufactured by Sanders Associates

\*\*Identify using ship Technical Manual Index

561-2.4.5 FLOW RATE ADJUSTMENT. With most servo valves, the maximum desired control surface rate is reached with less than maximum valve spool displacement. Therefore, one of the following techniques is used to limit the rate to some selected maximum level. (See paragraphs 561-3.1.1 and 561-3.2.1 for specific rates.)

- a. Physical hardstops (within the valve) are used to limit the servo valve main spool displacement.
- b. The servo amplifier electrical output is limited to the value required to produce the desired flow rate through the servo valve.
  1. A flow control valve is installed in the hydraulic piping to limit flow rate. Generally, the third method has been used in the past. However, when the low-noise servo valves were backfitted, the valves were designed with flow limiters (adjustable spool stops) and the flow control valves were removed from the hydraulic system because of their potential contribution to noise. Of those on the newer ships, SSN 688 class emergency mode is the only servo system that uses a flow control valve.

561-2.4.5.1 Rate Adjustment Using Valve Flow Limiters. On some of the earlier submarine classes, the only way to control the maximum ram rate is by adjusting the servo valve main spool displacement hardstops. The procedure to be followed to adjust the rate is provided in the servo valve technical manual identified in [Table 561-2-1](#). In most cases, these ships have the model SV-438-10P electrohydraulic servo valve installed. An exception to the above is the TRIDENT Class emergency control valve. This valve also uses flow limiters and is to be adjusted in accordance with its own technical manual.

561-2.4.5.2 Rate Adjustment Involving Servo Amplifiers. On most ships the maximum ram rate is adjusted by both setting the servo amplifier output and using the servo valve main spool displacement hardstops. This adjustment procedure is provided in the applicable servo valve technical manual, which will reference the servo amplifier technical manual as required. The TRIDENT normal mode electrohydraulic servo valve is a slight exception in that the rate is set and controlled entirely by the amplifier (or Position Control Unit). The servo valve technical manual need only be referred to if the valve null requires adjustment.

561-2.4.6 SERVO VALVE REPAIR. Because servo valves are fairly complex devices, repair should not be attempted by untrained personnel. Many valves have been damaged by improper disassembly by forces afloat. Any maintenance or repair work should be accomplished in accordance with, and only after careful study of, the applicable technical manual.

561-2.4.6.1 Shipboard Repair. Because most ships are provided with one or two spare servo valves, complete replacement of a malfunctioning servo valve with a spare valve is generally the preferred maintenance action. On some ships, repair parts are carried as spares, making possible to replace a troublesome component or the pilot stage assembly. Under normal circumstances, only trained personnel should undertake replacement, following step-by-step the procedures and precautions in the applicable technical manual.

561-2.4.6.2 Depot Level Repair. In that onboard repair of servo valves is generally limited to minor adjustments, servo valves will normally be repaired at tender or depot levels where trained personnel and test stand facilities are available.

561-2.4.6.3 Test Stands and Equipment. The equipment required to perform null adjustments, overhaul maintenance, and performance testing on a test stand is listed in servo valve technical manuals. This equipment is considered necessary for making a complete valve overhaul. However, for the most part, those tests required for valve maintenance can be made with less test-stand capability than that indicated in the technical manual. When servo valves are tested on a test stand with less than rated flow capacity, the flow limiters on the main stage should be adjusted so that the maximum flow rate through the valve will not exceed the test-stand capacity.

561-2.4.6.4 Servo Valve Filter Maintenance. Most of the steering and diving servo valve installations are equipped with filters to protect at least the pilot stage of the valve. Usually an external filter is installed in the pilot supply line and many of the servo valves are equipped with an additional internal filter. One of the most common causes for servo valve malfunction is a dirty filter that is preventing adequate flow to the pilot stage. Because this is the case, filter element maintenance should be accomplished prior to other repair or maintenance actions when servo valves are malfunctioning. External filters should be checked prior to removal of internal filters.

561-2.4.6.5 External Filters. Detailed guidance on the maintenance and cleaning (if applicable) of hydraulic filter elements, including required stock numbers, is provided in **NSTM Chapter 556, Hydraulic Equipment (Power Transmission and Control)**. The following factors often result in contaminants passing through the element and causing servo valve problems and should be forestalled by proper procedures and sound preventive maintenance, as indicated:

1. Infrequent element replacement. Differential pressure indicators are provided to signal maintenance need. Failure to respond to this signal causes higher differential pressures across the element, which may force contaminated fluid past O-ring seals.
2. Failure to install filter element. Under certain shipboard conditions such as lack of onboard spares and inad-

equate cleaning facilities, there is a temptation to assemble a filter housing which may have been improperly assembled without the element in spite of a requirement that filter elements must always be installed.

3. Installation of a damaged element. Repeated usage or rough handling can easily damage filter elements; this damaged condition, which may not be readily apparent, will allow passage of large particles through the element. Cleanable elements should be bubble-point tested prior to reuse after cleaning, as described in **NSTM Chapter 556, Hydraulic Equipment (Power Transmission and Control)** .
4. Ultrasonic cleaning of noncleanable elements. Noncleanable elements can physically resemble cleanable elements and may be damaged as a result of inadvertent ultrasonic cleaning. Noncleanable elements conforming to MIL-P-8815 for these applications will be marked NONCLEANABLE; however, some interchangeable proprietary elements may not carry such markings. Elements that are cleanable should be marked CLEANABLE. Use of noncleanable elements is recommended whenever possible.
5. Inadequate cleaning of elements. Many of the installed cleanable elements can be particularly difficult to clean, even by highly trained personnel under ideal conditions. Furthermore, the dirt capacity of these elements is generally small. Failure to restore elements to an as-new condition will result in high differential pressures in a short operating time, requiring maintenance as frequently as daily. These elements should be discarded. **NSTM Chapter 556, Hydraulic Equipment (Power Transmission and Control)** , provides filter element cleaning procedures.
6. Damaged or missing O-ring seals. Excessive temperatures, rough handling, or repeated use can lead to deterioration of the O-ring seals. Satisfactory O-rings are required to seal both the element and an automatic cut-off diaphragm which is a special feature commonly incorporated in these filter housings. Defective O-rings allow leakage and pressure loss of the filter elements.
7. Improper filter housing installation. Inlet and outlet ports are identical; therefore it is possible to install the housing in reverse even though the ports are generally stamped IN and OUT. The resulting reverse flow through the housing can ruin the element, washing both trapped dirt and filter material into downstream components.
8. Improper filter elements installation. Filter elements may have been installed upside down in a filter bowl, providing no filtration. Proper installation requires that the closed end of the element be at the bottom of the filter bowl and that the open end fit up into the mating area of the filter head. Furthermore, the bottom of these filter elements is usually provided with a bellville washer or similar spring assembly to keep the element seated when installed. Removal of these spring assemblies allows fluid to bypass the element.
9. Improper maintenance procedures. Upon insertion of a new element into a filter bowl prior to reassembly, the bowl and element should be filled with oil to minimize air entrainments and associated hazards upon repressurization. The previously drained oil, or other contaminated oil, shall not be poured into the element, since this oil and dirt will reach downstream components. Only clean system fluid shall be used.

561-2.4.6.6 Internal Filters. Because all servo valves do not have internal filters and some filters cannot be readily maintained, the appropriate servo valve technical manual should be consulted for filter maintenance procedures. Internal screens are installed in some configurations of the SV-438-10P and SV-438-15P servo valves, but maintenance and replacement must be accomplished by trained personnel. Most Bendix (Honeywell Corp.) servo valves have cleanable internal block filters. These may be cleaned using the procedure in the servo valve technical manual if maintenance of the external filter does not correct servo valve operation.

## **561-2.5 POWER TRANSFER VALVES**

561-2.5.1 GENERAL. Control systems for fairwater diving planes, stern diving planes, and the rudder each utilize a power transfer valve.



561-2.5.2 FUNCTIONAL DESCRIPTION. Power transfer valves are six-way, two-position spool-and-sleeve-designed directional control valves. Pilot pressure for actuating the valve spool is supplied to the chambers at each end of the spool. One end of the spool is supplied from the normal control mode hydraulic system via a solenoid-operated pilot valve; the other end is supplied by the emergency control mode hydraulic system.

561-2.5.2.1 An imbalance in the effective end areas of the spool normally causes the spool to be shifted to its normal control mode position, allowing pressurized fluid from the normal mode hydraulic system to be ported to the control surface hydraulic cylinder. When the pressure on the normal control mode (larger) end of the spool is relieved, the spool shifts to the emergency control mode position and allows fluid from the emergency control mode hydraulic system to be ported to the control surface hydraulic cylinder.

561-2.5.2.2 A limit switch, an integral part of the valve, is actuated by the valve spool when the spool shifts to its emergency mode position. The limit switch contacts then energize the circuits to the emergency mode indicator light and the audible alarm buzzer, while deenergizing the circuits to the power transfer valve pilot valve solenoid and the normal mode indicator light.

561-2.5.2.3 On SSN 688 Class ships, the stern diving plane and rudder power transfer valves are mounted directly adjacent to their hydraulic cylinders, which have integral porting for the hydraulic fluid. The fairwater diving plane power transfer valve is located inside the pressure hull and is connected by appropriate piping to the fairwater diving plane hydraulic cylinder in the bridge access trunk in the sail.

561-2.5.3 INSTALLATION AND ASSEMBLY. Mechanical failure of the power transfer valve will result in loss of both normal and emergency control modes. Therefore, particular attention shall be given to verification of proper assembly and installation. When valves or attaching flanges are assembled, the proper torque must be applied evenly to all fasteners to prevent overloading and resultant failure of one or more of the fasteners. Of prime concern are the fasteners that function to secure: the end caps to the valve body; the pipe flanges to the subplate or valve, depending upon the specific design; and the valve body to the subplate or cylinder, if so designed. During each reassembly, these fasteners must be uniformly torqued to the precise values given on applicable assembly drawings. If values are not listed on drawings, general torque values for fasteners can be obtained from **NSTM Chapter 556, Hydraulic Equipment (Power Transmission and Control)** . Future plans are for these values to be presented in **NSTM Chapter 075, Fasteners** .

561-2.5.4 POWER TRANSFER VALVE PILOT VALVES. The control systems for the rudder, stern diving planes, and fairwater diving planes each have their own solenoid-operated power transfer valve pilot valve that serves to position the power transfer valve spools.

561-2.5.4.1 The power transfer valve pilot valve for each control surface provides the means by which the operator, or the electrical control system, can initiate a shift of the power transfer valve. The power transfer valve pilot valve makes this shift by venting the power transfer valve normal supply pilot line in response to an interruption of electrical power to its solenoid or in response to a manual override operation.

561-2.5.4.2 The power transfer valve pilot valve is generally a three-way, two-position solenoid-controlled control valve. It is of a spool-and-sleeve design, normally electrically controlled in one direction, but able to be manually operated by an override. The valve is spring-loaded to shift to the other operating position whenever the solenoid is deenergized.

561-2.5.4.3 When the solenoid is energized, the valve spool shifts to permit hydraulic fluid from the normal control mode supply to pressurize the large end of the power transfer valve spool, keeping the power transfer valve in its normal mode position. When the solenoid is deenergized, the pilot valve relieves the fluid pressure on the large end of the power transfer valve spool by porting it to the normal control mode return, permitting the power transfer valve to shift to its emergency mode position. The pilot valve can also be pin-locked in this latter position to hold the power transfer valve in its emergency mode position. The failure-detection circuit monitoring the control surface action initiates the automatic shift to emergency by interrupting power to the applicable power transfer pilot valve solenoid under any of the applicable fail-detect conditions previously discussed. Power to the solenoid can be manually interrupted by shifting the associated mode selector switch to the emergency position.

## **561-2.6 CONTROL SURFACE ANGLE INDICATION SYSTEMS**

561-2.6.1 GENERAL. In most submarine installations, the following three independent angle-indication systems are provided:

1. Normal
2. Auxiliary
3. Mechanical

561-2.6.2 NORMAL ANGLE INDICATION. The rudder, fairwater/bow plane, and stern plane angle indicator systems (IC circuits N, NB, and NS, respectively) generate control surface position signals to position rudder and plane angle indicators on the ship control panel. Actual rudder angle is generally repeated on the portable bridge IC control unit, if provided. The indicators are positioned as stated in paragraph [561-2.6.2.1](#).

561-2.6.2.1 IC circuits N, NB, and NS each contain a synchro transmitter that is mechanically linked to the hydraulic ram of the associated control circuit. The magnitude and phase of signals transmitted are determined by the angular relationship of the rotor and stator of the synchro transmitter. The angle signals are converted by synchro receivers at the ship control station to angle indication. Circuits N, NB, and NS generally utilize 120-volt 60-Hz single-phase AC power.

561-2.6.3 AUXILIARY ANGLE INDICATION. Auxiliary circuits XN, XNB, and XNS provide supplementary indication of the approximate angle (within 5 degrees) of the rudder, fairwater/bow planes, and the stern planes by lighting numerals on the perimeters of the combined normal and auxiliary rudder and plane angle indicators on the ship control panel. If one of the normal circuits becomes inoperative, the auxiliary circuit continues to provide approximate angle indication. Both normal and auxiliary circuits are energized when the ship is underway. Operation is as follows:

561-2.6.3.1 IC circuits XN, XNB, and XNS each contain a circuit-making transmitter that is mechanically linked to the hydraulic ram of the associated control surface. Each transmitter consists of a contact arm and several contact buttons that are wired to the indicating lights on the angle indicators at the ship control station.

561-2.6.3.2 Circuits XN, XNB, and XNS are generally powered by 120-volt AC stepped down by a 120/6-volt transformer that supplies 6 volts AC to the transmitter. If the 6-volt AC supply fails, an automatic shift to a 6-volt DC dry cell battery source occurs.



561-2.6.4 MECHANICAL ANGLE INDICATORS. Generally, the mechanical indicators for the rudder and stern diving planes each consist of a bar engraved in 1-degree increments corresponding to the particular control surface actual angular positions. The engraved bar is mounted parallel to the control surface operating rod. An indicating pointer is attached to the control surface operating rod. Movement of the operating rod causes the pointer to move along the engraved bar, indicating the angular positions of the particular control surface. After all adjustments have been made to the system, the angular positions are scribed on the bar by setting the control surface to a specific angle and scribing the indicator bar to match. Thus, the mechanical indicators can be used as a reference for the rudder and stern diving plane actual angular position and can be used to align the angle transmitters and auxiliary angle transmitters. The description in paragraphs 561-2.6.4.1 through 561-2.6.4.4 is applicable as indicated.

561-2.6.4.1 General. Typically, the mechanical indicator for the fairwater diving planes is part of the fairwater diving plane feedback drive gear assembly. The input shaft to the bevel gears of the feedback drive gear assembly is extended, and a pointer is attached to the end of the extended shaft. The pointer rotates to indicate the angular positions of the fairwater diving planes. The indicator plate is scribed in 1-degree increments corresponding to the actual angular positions of the fairwater diving planes. The scribing is done after final adjustments have been made to the system and, therefore, indicates the exact angular positions of the fairwater diving planes.

561-2.6.4.2 Control Surface Angle Reference. Each mechanical indicator is located within sight of its respective local manual control valve, thereby affording the operator an immediate control surface angle reference.

561-2.6.4.3 Inspection Procedures. The fairwater diving plane feedback drive gear installed aboard SSN 642 (formerly an SSBN 640 Class) requires special attention because of the basic design. The mechanical indicator and feedback transmitters are driven by a long rod (indicating linkage) that penetrates the pressure hull between the bridge access trunk and control room. Periodically, when other maintenance is performed in the general area, inspect the linkage as follows:

1. Examine all linkage for straightness and conformance to applicable assembly drawings and detail drawing listed thereon.
2. Examine linkage installation for any obstruction that would interfere with, or contact, the linkage during normal linkage motion.
3. Check the linkage orientation. All linkage pins should be parallel to one another with their axes oriented as shown on the applicable assembly drawing.
4. Check the bearings at the ends of the individual links for corrosion or binding; lubricate, rework, or replace as required.
5. Check the link passing through the pressure hull stuffing box for binding, chattering, or noisy operation during movement of the fairwater planes. Observe inside the pressure hull and the bridge access trunk. Any of the aforementioned symptoms may indicate a buildup of dried out, caked grease in the V-ring stuffing box or rod bushing.

561-2.6.4.4 Corrective Action. When discrepancies are uncovered during inspection, take corrective action as follows:

### CAUTION

**During disassembly, the exact position of all pieces should be noted and the exact number of turns to remove rod end bearings recorded because the feedback synchros are readily rendered out of proper adjustment if not properly reassembled**

1. Remove the link passing through the pressure hull stuffing box. Unbolt and remove the V-type packing gland. Unbolt and remove the stuffing box bushing. Because this bushing does not unbolt on the SSN 598 Class, do not attempt to remove it on this class ship. Remove V-ring packing and any hardened grease in the stuffing box. It is advisable to install new V-rings; however, under conditions requiring expediency, if the old rings appear adequate, they may be reinstalled. Lubricate the entire surface of each V-ring component with Ter-malene 2 (CID A-A-50433) grease and install packing in accordance with **NSTM Chapter 078, Gaskets, Packings, and Seals** .
2. Reassemble gland and linkage. Using grease conforming to CID A-A-50433 grease the gland through the grease fitting. CID A-A-50433 grease is available in the stock system in the following quantity:
  - a. 35 - pound (NSN 9150-01-306-9167)
3. Verify that the feedback synchros, plane angle transmitters, and mechanical angle indicator are functioning properly by cycling the planes in normal mode and observing and comparing performance and electrical and mechanical angle indication to the specific ship requirements. Hard stop, rise, and dive angle indication in emergency mode operation should also be checked. The adjustment procedure, if required, is generally provided on applicable fairwater diving gear follow-up and transmitter drive assembly drawings.

561-2.6.4.5 Inspection of Angle Indicator and Feedback Transmitters. On all submarines, whenever work is accomplished in the vicinity of the rudder, stern diving, or fairwater/bow diving feedback transmitter linkages, the activating linkages should be inspected for ruggedness, proper clamps, presence of set screws, and security of connecting pins. If bolts are used in these systems for connecting linkages of securing vital components, they shall be installed in a position such that a loss of the nut will not permit the bolt to fall out as a result of gravitational forces.

## **561-2.7 STEERING AND DIVING HYDRAULIC CYLINDERS**

561-2.7.1 OVERVIEW. Each control surface (fairwater/bow plane, stern plane, and rudder) is driven by a hydraulic cylinder. The hydraulic cylinder, with a set of operating linkages and a yoke/stock assembly, functions to transform hydraulic energy into linear motion and then into angular motion to operate the control surface. For a typical cylinder assembly see [Figure 561-2-7](#). Specific design features, primary areas of hydraulic cylinder maintenance, and procedures to ensure proper reassembly are discussed herein. For applicable repair procedures to components of the hydraulic cylinders see [Appendix A](#) through [Appendix E](#).

561-2.7.2 PISTON ROD PACKING AND PISTON SEALS. Where the piston rod passes through the cylinder head, V-type packing is generally used as a seal. On SSN688 Class and later ships, two sets of packing are provided (See figures [561-2-8](#) and [561-2-9](#)). This arrangement permits replacing the primary (outer) packing without having to isolate the hydraulic cylinder. During normal operation, the space between the two sets of packing is open to normal internal cylinder pressure. This situation results in a lack of differential pressure across the inner

packing set and, therefore, negligible wear. Should primary packing leakage become intolerable, the normally pressurized space between the packing sets, now isolated from internal cylinder pressure, becomes depressurized and the inner packing begins to act as the primary seal. At this time, the outer packing can be replaced at first availability and then the cylinder restored to normal operation. The quad-ring is used as a piston seal in most installations, but in several early designs a leather U-cup seal was used for this purpose.

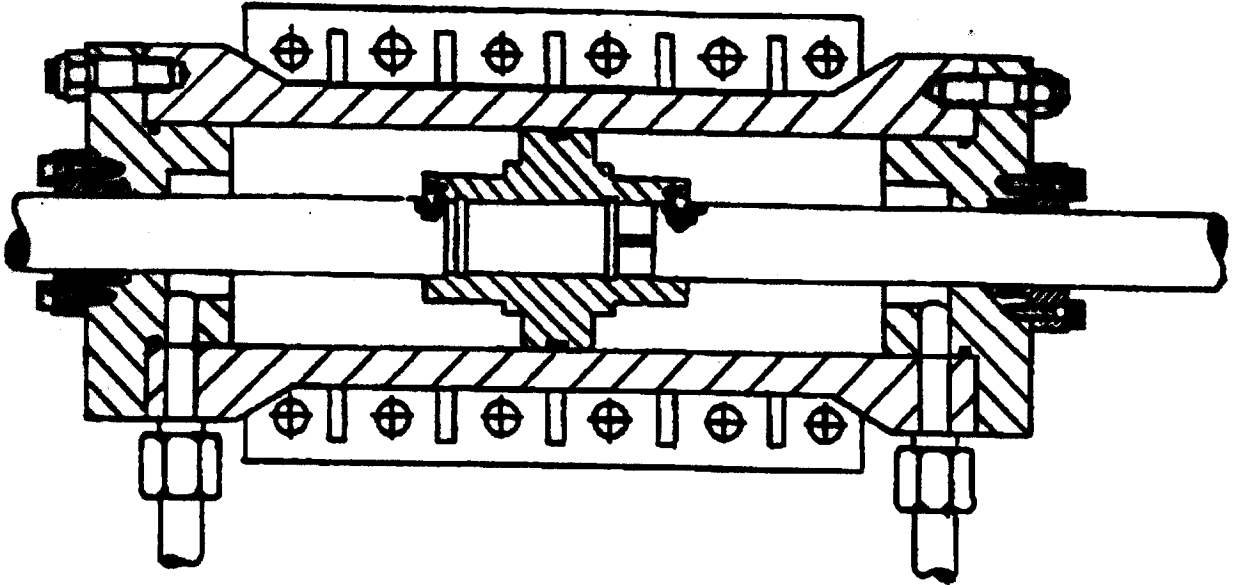

Figure 561-2-7. Typical Steering and Diving Hydraulic Cylinder

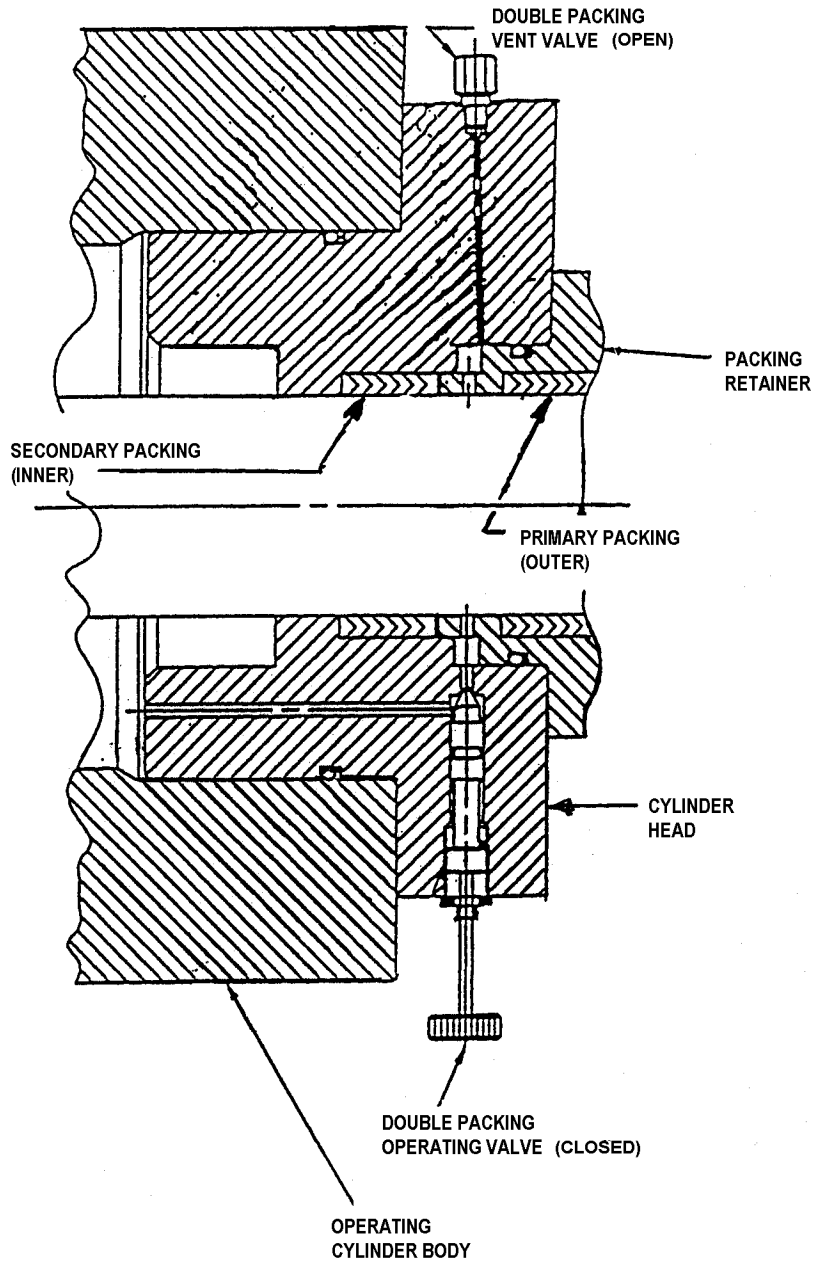

Figure 561-2-8 Cylinder Double Packing Secondary (Inner) Packing Engaged

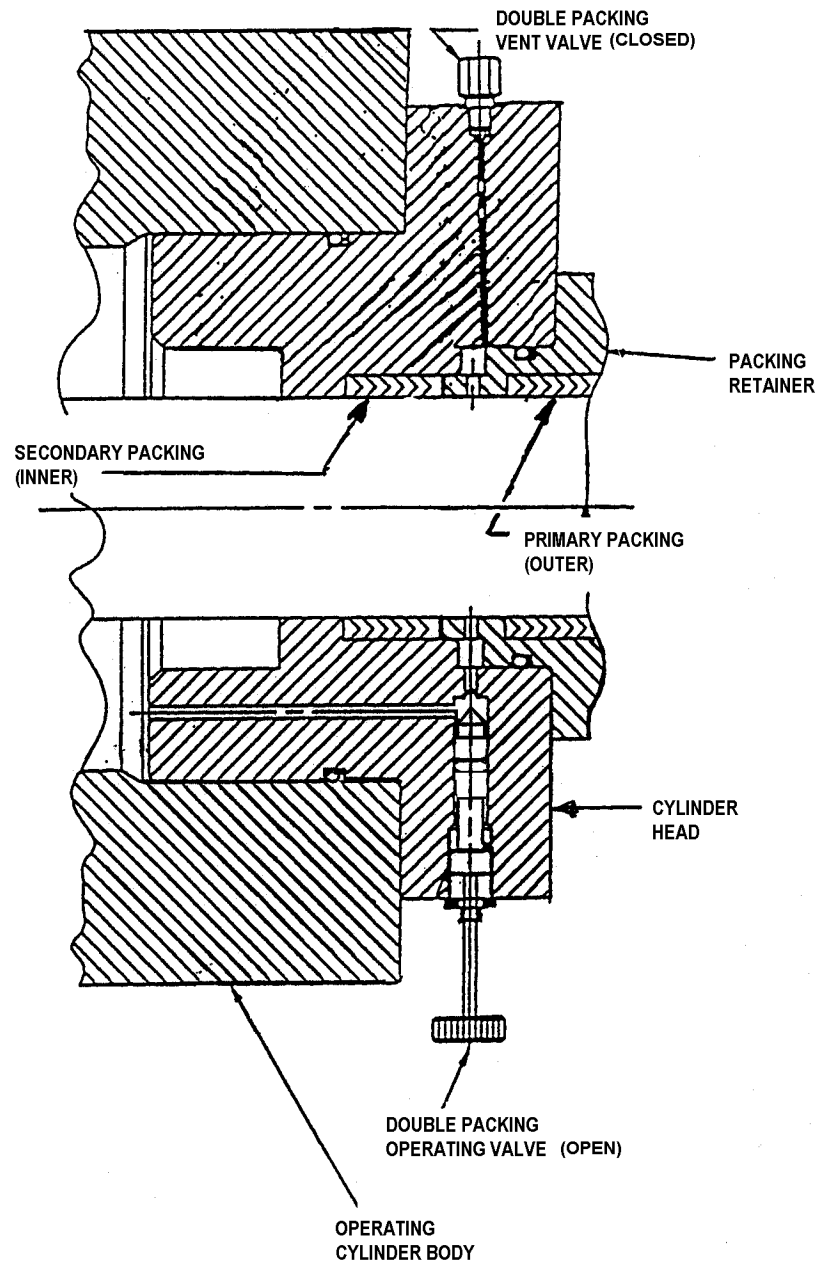

Figure 561-2-9 Cylinder Double Packing Primary (Outer) Packing Engaged

561-2.7.3 DYNAMIC SEAL LEAKAGE. Steering and diving system dynamic (reciprocating) seals are affected by extrusion, side loads, surface finish of the metal, concentricity of mating metal parts, seal hardness, squeeze, stroke speed, lack of lubrication, use of back-up rings, and compatibility of the seal material with system fluid. A newly installed seal will allow little or no leakage. However, with continued use, the factors listed above, in addition to system contamination, tend to reduce the effectiveness of the seal and increase the likelihood of leakage. Improper installation and damage during installation can be important factors in limiting seal life.

561-2.7.3.1 External Seals. Leakage from external seals (i.e., leakage that is external to the component such as

that from the cylinder piston rod seal) is usually easily detected by visual observation. Generally, the most serious effect of this leakage is the oil accumulation and resultant housekeeping required. These seals are usually replaced before leakage becomes bad enough to affect operation of the cylinder or the ability to hold loads without drifting.

**561-2.7.3.2 Internal Seals.** Leakage from internal seals (i.e., leakage that is confined within the component such as within the seal on a cylinder piston) is difficult to determine and measure without conducting a test. Because the leakage is internal, it is often undetected until it becomes serious enough to significantly affect system operation. For example, on one nuclear submarine it was found that the stern planes were not functioning properly. Above 8 knots it became increasingly difficult to make the stern planes move in the rise direction. Continuous oil flow to the ram indicated that the seals on the piston of the stern diving cylinder had failed. At slow ship speeds, sufficient differential pressure could be generated across the piston to move the planes, but at higher ship speeds operation was very sluggish. This example indicates the importance of periodically testing the piston seals of steering and diving cylinders.

**561-2.7.3.3 Criteria for External Seals.** For external seals such as piston rod seals and similar applications, the leakage criteria in paragraphs [561-2.7.3.4](#) and [561-2.7.3.5](#) apply.

**561-2.7.3.4 New Seals.** For newly installed seals, a slight wetting of the tail rod is acceptable. Another acceptance criterion that may be used is the formation and dripping of not more than one drop of fluid every 25 cycles for each inch of rod diameter or fraction thereof. For example, a cylinder with a 2-1/4-inch tail rod would be allowed three drops of fluid per 25 cycles. A cycle for a cylinder is defined as operation from a fully retracted position to the fully extended position and back again to the fully retracted position.

**561-2.7.3.5 Replacement Seals.** In many cases, housekeeping problems resulting from leakage may be the primary factor in determining whether or not seal replacement is necessary. If, when the cylinder is not operating, leakage exceeds 4 milliliters per hour for each inch of seal diameter or fraction thereof, the seal should be replaced. If leakage occurs primarily during cycling of the cylinder, a leakage rate in excess of 1 milliliter per inch of rod (or seal) diameter or fraction thereof for every 10 cycles may be used as a criterion for replacement.

**561-2.7.3.6 Criteria for Internal Seals.** In the case of piston seals and similar internal applications, minor leakage is not detrimental. However, an increase in leakage is an early warning of seal deterioration. Leakage criteria selected should be those which will result in seal replacement before serious failure of the seal occurs.

**561-2.7.3.7 Replacement Criteria.** Because of cylinder design, measurement of piston seal leakage in most steering and diving system cylinders is limited to a static test. In general, internal piston seals should be replaced when leakage exceeds 5 milliliters per inch of seal diameter (or cylinder bore) per 5 minutes with the test pressure as close to operating pressure as practical.

**561-2.7.3.8 Leakage After Seal Replacement.** Following installation of new seals, there should be almost no leakage across the seal, particularly under static conditions. However, cylinders that are scored or otherwise damaged may leak slightly. The recommended maximum acceptable leakage is 1 milliliter per 10 minutes per inch of seal diameter.

**561-2.7.3.9 Cylinder Seal Leakage Test.** To determine hydraulic cylinder seal leakage rates, conduct one of the following applicable static tests annually (as a minimum). For valve numbers and relative direction of piston movement, see [Figure 561-2-10](#) or [Figure 561-2-11](#) as applicable. For convenience in measuring piston seal leakage use ShipAlt SSN 2647D or MIL-V-24695 sampling components and guidance of **NSTM Chapter 556, Hydraulic Equipment (Power Transmission and Control)**, section 556-4.2.

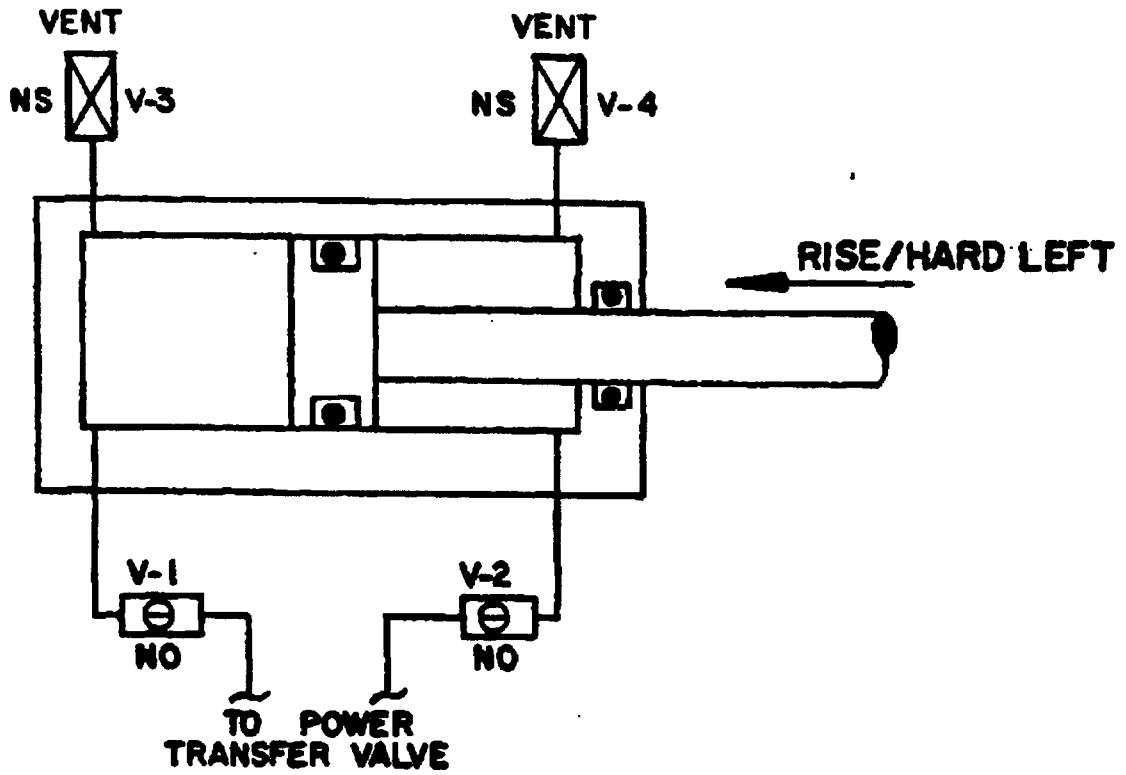

Figure 561-2-10. Cylinder Seal Leakage Test (Applicable to SSN637 Class and SSN642)

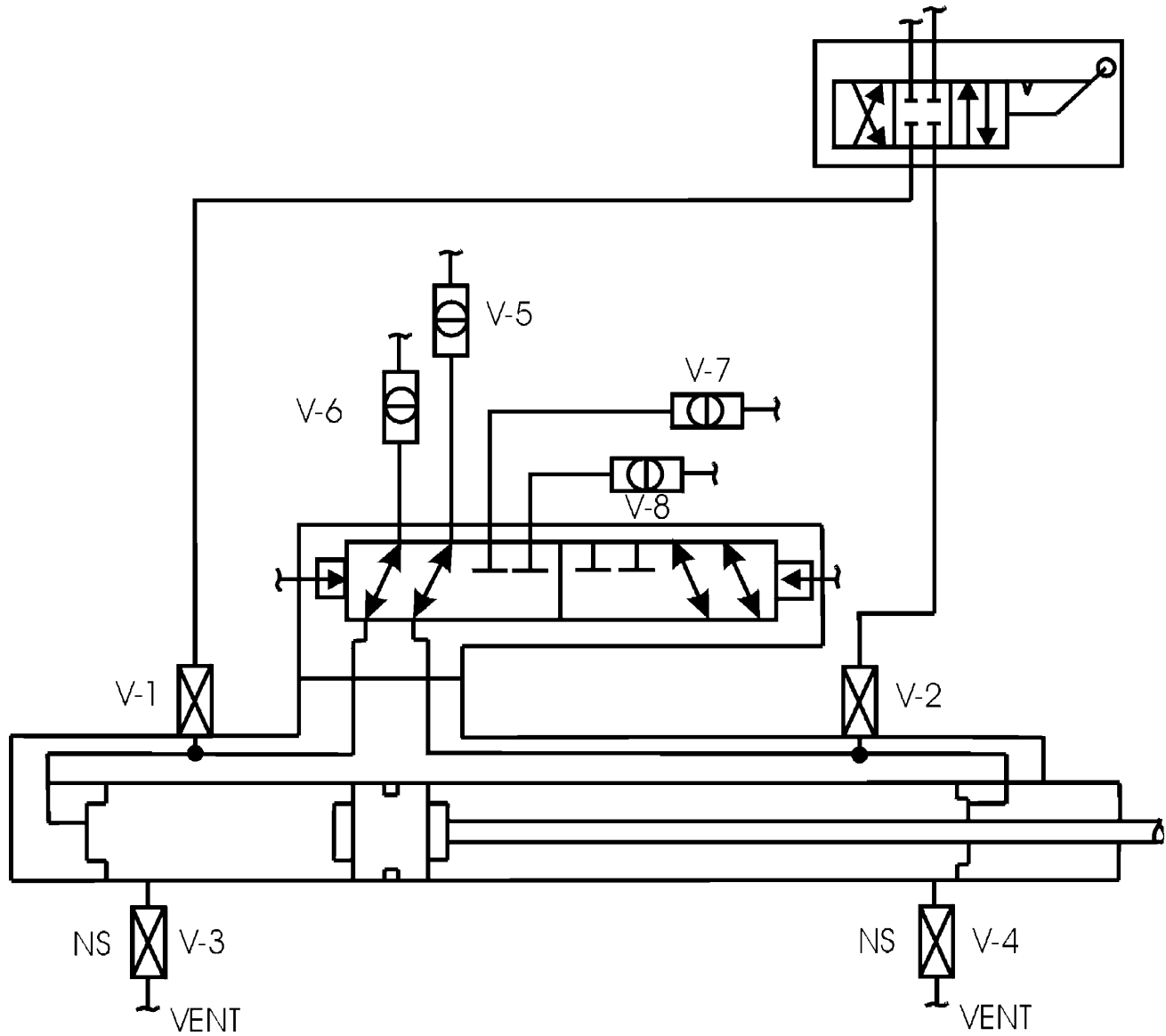

Figure 561-2-11. Cylinder Seal Leakage Test With Power Transfer Valve Attached (Applicable to SSN 688 Class and SSBN 726 Class)



561.2.7.3.9.1 1 The following procedure can be used for SSN 637 Class and SSN 642:

1. In local or emergency mode, slowly operate cylinder to the hard rise or hard left position until the hardstops are engaged.

**NOTE**

Stern Planes hydraulic cylinder is within the SUBSAFE boundary; use appropriate safety precautions.

2. Continue applying hydraulic pressure to V-2, while shutting V-1 and V-2.
3. Very carefully and slowly open V-3; if flow of hydraulic fluid does not cease within a few seconds, it may indicate that V-1 may leak. Leaking valves must be repaired before continuing the test.
4. Shut V-3 and apply hydraulic pressure through V-2 or in the hard rise/hard left direction using the local manual control valve or the emergency control valve.
5. Slowly open V-3; collect the leakage downstream of V-3 for a 5-minutes period.
6. Observe tail rod seal for leakage under static and dynamic (operating) conditions.

**NOTE**

If leakage is between 1 and 5 milliliters (1 milliliter equals approx.20 drops) per inch of seal diameter, sealing surface should be inspected and repaired and piston seal replaced at first convenient opportunity. If leakage exceeds 5 milliliters per inch of seal diameter, sealing surface inspection and repair, and seal replacement should be accomplished immediately. If a new piston seal is installed, the leakage test should be repeated. Maximum allowable leakage for a new seal is ½ milliliter per inch of seal diameter.

561.2.7.3.9.2 1 The following procedure can be used for SSN 688 Class and SSBN 726, refer to [Figure 561-2-11](#) for valve numbers and relative location within the system:

1. In local or emergency mode, slowly operate cylinder to the hard rise or hard left position until the hardstops are engaged.

**NOTE**

Stern Planes hydraulic cylinder is within the SUBSAFE boundary; use appropriate safety precautions.

2. Continue applying hydraulic pressure to V-2, and shut or verify shut V-1, V-2, V-3, V-4, V-5, V-6, V-7, and V-8.
3. Very carefully and slowly open V-3; if flow of hydraulic fluid does not cease within a few seconds, it may indicate that V-1, V-2, V-3, V-4, V-5, V-6, V-7, V-8, or any combination is leaking. Leaking valves must be repaired and verified for no leakage before continuing the test.
4. Shut V-3 and apply hydraulic pressure through V-2 or in the rise/left direction using the local manual control valve.
5. Slowly open V-3; collect the leakage downstream of V-3 for 5-minutes.
6. Observe tail rod seal for leakage under static and dynamic (operating) conditions.

**NOTE**

If leakage is between 1 and 5 milliliters (1 milliliter equals approx.20 drops) per inch of seal diameter, sealing surface should be inspected and repaired and piston seal replaced at first convenient opportunity. If leakage exceeds 5 milliliters per inch of seal diameter, sealing surface inspection and repair, and seal replacement should be accomplished immediately. If a new piston seal is installed, the leakage test should be repeated. Maximum allowable leakage for a new seal is ½ milliliter per inch of seal diameter.

561-2.7.3.10 Summary of Dynamic Seal Leakage Requirements. Acceptable dynamic seal leakage rates for external and internal dynamic seals are summarized in [Table 561-2-2](#). [Table 561-2-3](#) provides allowable leakage for both new and in service seals for various ship classes and systems. All leakage rates are based on a fluid temperature of 37.8°C (100°F). If the system fluid temperature is lower or higher than 37.8°C (100°F) during performance of the tests, a leakage correction factor should be applied, which is provided at the end of [Table 561-2-3](#). For relative leakage rates based on fluid viscosity, see **NSTM Chapter 556, Hydraulic Equipment (Power Transmission and Control)** . If excessive leakage is measured at temperatures over 37.8°C (100°F), a retest with cooler fluid is recommended in lieu of applying leakage correction factors.

561-2.7.4 REPLACEMENT OF PISTON ROD PACKING. Comprehensive guidance regarding installation of V-ring packing is provided in NSTM Chapter 078, Seals. The following is a general procedure for installation of V-ring packing in steering and diving hydraulic cylinders. It should be noted that some submarines have been provided with locking devices that, when installed between the guide cylinder and coupling and the hydraulic cylinder and coupling, lock the coupling in the center position to prevent movement of the operating gear.

1. Install the aforementioned locking device, if available.
2. Isolate the hydraulic cylinder from the hydraulic power source. Depressurize the cylinder using vent fittings on cylinder; drain the cylinder using drain fittings. Leave vent fittings in open position to preclude any pressure buildup in the cylinder as a result of component leakage. Unfasten packing gland and remove packing to be replaced.
3. Select packing components in accordance with size and material requirements specified on the applicable drawing.
4. Install V-ring packing in accordance with instructions in **NSTM Chapter 078, Seals** .
5. Reinstall the packing gland. Lubricate gland fasteners with molybdenum disulfide in accordance with MIL-M-7866, and tighten the fasteners to the appropriate torque values listed in [Table 561-2-4](#). Ensure clearance exists between the ID of the gland and the OD of the shaft.
6. Observing standard shipboard precautions, slowly refill cylinder using low pressure fluid; vent off all air. Secure vents and bring cylinder slowly up to normal operating pressure, observing for leaks. Realign system for normal operations.

561-2.7.5 PISTON/CYLINDER HEAD CLEARANCE. Shipbuilding specifications require that the steering and diving hydraulic cylinders be designed so that the piston clears heads by at least 1/4 inch when the control surface is in the hardover (mechanical hardstop) positions. Most installations have been designed to provide 1/2 inch or more clearance. This additional clearance allows minor variation in the location of the cylinder, linkage manufacturing tolerances, and coupling shim thickness.

561-2.7.5.1 Recommended Verification Procedure. The following piston/cylinder head clearance verification procedure is the most accurate. Follow this procedure whenever possible:

1. With the cylinder fully assembled, but prior to installation in the ship, bottom the piston at both ends of the cylinder and measure and record dimensions A and B as shown in [Figure 561-2-12](#).

**NOTE**

Measurements are to be made to the shoulder where the threads end and the polished portion of the rod begins rather than to the end of the piston rod. This is necessary to allow additional measurements when the coupling is installed. These dimensions should be measured to the nearest sixteenth of an inch and engraved on the end of the cylinder in decimals as shown in Figure 561-2-12.

**Table 561-2-2 SUMMARY OF DYNAMIC SEAL ALLOWABLE LEAKAGE RATES** <sup>NOTE 1</sup>

<b>PART A - EXTERNAL SEALS (PISTON ROD)</b>		
<b>Maximum Leakage for New or Replacement Seals</b> <sup>NOTE 2</sup>	<b>Recommended Maximum Acceptable Leakage Prior to Seal Replacement</b>	
	Dynamic Test	Static Test
1 drop/25 cycles for each inch of rod diameter or fraction thereof	1 mL per 10 cycles per inch of rod diameter or fraction thereof	4 mL/hr per inch of rod diameter or fraction thereof
<b>PART B - INTERNAL SEALS (PISTON)</b>		
<b>Leakage Rate (Static test only)</b>	<b>Seal Condition</b>	<b>Corrective Action</b>
Less than 1 mL/10 minutes per inch of seal diameter (cylinder bore) or fraction thereof	New seal condition	None
Less than 1 mL/5 minutes per inch of seal diameter (cylinder bore) or fraction thereof	Satisfactory	None
1 mL to 5 mL per 5 minutes per inch of seal diameter (cylinder bore) or fraction thereof <sup>NOTE 3</sup>	Marginally satisfactory	Seal replacement should be scheduled for first convenient opportunity. If corrective action is not initiated within 3 months, the leakage test should be repeated.
More than 5 mL/5 minutes per inch of seal diameter (cylinder bore) or fraction thereof <sup>NOTE 3</sup>	Unsatisfactory	Replace piston seal.
<b>Approximate Conversion Factors for Leakage Measurement</b>		
1 milliliter	= approx 20 drops	
1 teaspoonful	= 1/6 fluid ounce	= 5 mL
1 tablespoonful	= 1/2 fluid ounce 1 cubic inch 1 fluid ounce	= 15 mL = 16.4 mL = 30 mL
1 cup	= 8 fluid ounces	= 236 mL
1 quart	= 32 fluid ounces	= 0.95 liters
1 gallon	= 128 fluid ounces	= 3.78 liters

<sup>NOTE 1</sup>: All leakage rates are based on normal system operating pressures and a temperature of 37.8°C (100°F).

<sup>NOTE 2</sup>: Leakage rates are applicable to both hydraulic cylinder rod seal as well through hull rod chevron packing seals.

<sup>NOTE 3</sup>: Add 180 mL/5 minutes (SSN 688 CL) and 1800 mL/5 minutes (SSBN 726 CL) for rudder and stern planes hydraulic cylinders.

**Table 561-2-3** ALLOWABLE CYLINDER AND PISTON ROD LEAKAGE

CLASS	PISTON SEAL		TAIL ROD SEAL	
	NEW mL/10min	USED mL/5min	New drops/25 cyc.	Used mL/10 cyc.
<b>SSN 637 Class</b>				
Stern Diving Planes	9mL	45mL	4drops	4mL
Rudder	11mL	55mL	5drops	5mL
Fairwater Planes	7mL	45mL	3drops	3mL
<b>SSN 642</b>				
Stern Diving Planes	11mL	55mL	5drops	5mL
Rudder	13mL	65mL	5drops	5mL
Fairwater Planes	11mL	55mL	5drops	5mL
<b>SSN 688-750 Class</b>				
Stern Diving Planes	11mL	55mL	5drops	5mL
Dive Stop Rod			5drops	5mL
Rudder	13mL	65mL	5drops	5mL
Fairwater Planes	13mL	65mL	4drops	4mL
<b>SSN 751-773 Class</b>				
Stern Diving Planes	11mL	55mL	5drops	5mL
Dive Stop Rod			5drops	5mL
Rudder	13mL	65mL	5drops	5mL
Bow Planes	11mL	55mL	4drops	4mL
<b>SSN 718 Only</b>				
Inner Stern Diving Planes	8mL	40mL	4drops	4mL
Outer Stern Diving Planes	8mL	40mL	4drops	4mL
Rudder	13mL	65mL	5drops	5mL
Fairwater Planes	13mL	65mL	4drops	4mL
<b>SSBN 726 Class</b>				
Stern Diving Planes	14mL	70mL	6drops	6mL
Rudder	15mL	75mL	7drops	7mL
Fairwater Planes	16mL	80mL	8drops	8mL
<b>SSN 21 Class</b>				
Inner & Outer St Dvg Planes	8mL	40mL	4drops	4mL
Rudder	14mL	70mL	6drops	6mL
Fairwater Planes	9mL	45mL	5drops	5mL
<b>NOTE</b>				
Allowable seal leakage is based on 2190 TEP oil at 100°F. Multiply allowable leakage by the following correction factors to correct for oil temperatures other than 100°F.				
TEMPERATURE		CORRECTION FACTOR		
60°F		.3		
70°F		.4		
80°F		.6		
90°F		.8		
100°F		1.0		
110°F		1.3		
120°F		1.7		
130°F		2.2		
140°F		2.8		

**Table 561-2-4** PACKING GLAND FASTENER TORQUES (FT-LB)

Class Applicability	Stern Diving		Rudder		Fairwater/Bow	
	Molykote G	Molykote P37	Molykote G	Molykote P37	Molykote G	Molykote P37
SSN 637 Class	32-40		32-40		65-75	
SSN 642	32-40		32-40		32-40	
SSN 688 Class	54-60	72-80	59-65	79-87	54-60	72-80
SSBN 726 Class	330-350	440-480	330-350	440-480	655-675	885-910
SSN 21 Class		216-264		720-880		70-84
SSN 774 Class		240-280		240-280		90-110

2. After installing the cylinder and coupling assembly, or any time thereafter when it is necessary to determine the clearance, measure dimensions As and Bs as shown in [Figure 561-2-12](#).

#### NOTE

With the control surface in the two extreme limits of travel (mechanical hardstops) dimensions As and Bs are measured between the same two points used to determine dimensions A and B. The piston/cylinder head clearances are determined by subtraction as shown on [Figure 561-2-12](#). The procedure described is not suitable for unmarked cylinders that are already installed in the ship, because it is not possible to bottom the piston against both ends of the cylinder after installation. An earlier procedure used by some activities required that the dimension of the piston rod extension at the mid-point position be etched on the end of the hydraulic cylinder, whereas the current procedure requires etching of the piston rod extension dimensions when the piston is at the bottomed positions.

561-2.7.5.2 Alternative Verification Procedure. The steering and diving system arrangement drawings for most ships give a dimension from the hydraulic cylinder to the center of the coupling that centers the piston in the cylinder. This is sometimes identified as the 0 or zero degrees condition. If necessary, use the following procedure as an alternative for verifying correct clearances.

1. With the coupling at the distance listed on the drawing for the 0 degree condition, measure the distance the piston is required to travel to move the piston rod into the hardstops in each direction.
2. Compare these travel distances with one-half the distance the cylinder travels (as determined from the cylinder drawing) to determine if the minimum 1/4-inch end clearance exists. For example:

cylinder stroke (max) = 26.0 inches

piston movement (forward) = 12.2 inches (forward)

piston movement(aft) = 12.9 inches (aft)

one-half cylinder stroke =  $26.0/2 = 13.0$  inches

forward head/piston clearance = one-half cylinder stroke - piston movement (forward)

ENGRAVE (DIMENSIONS A & B)  
 NOTE: B IS THE LARGER OF  
 THE TWO DIMENSIONS

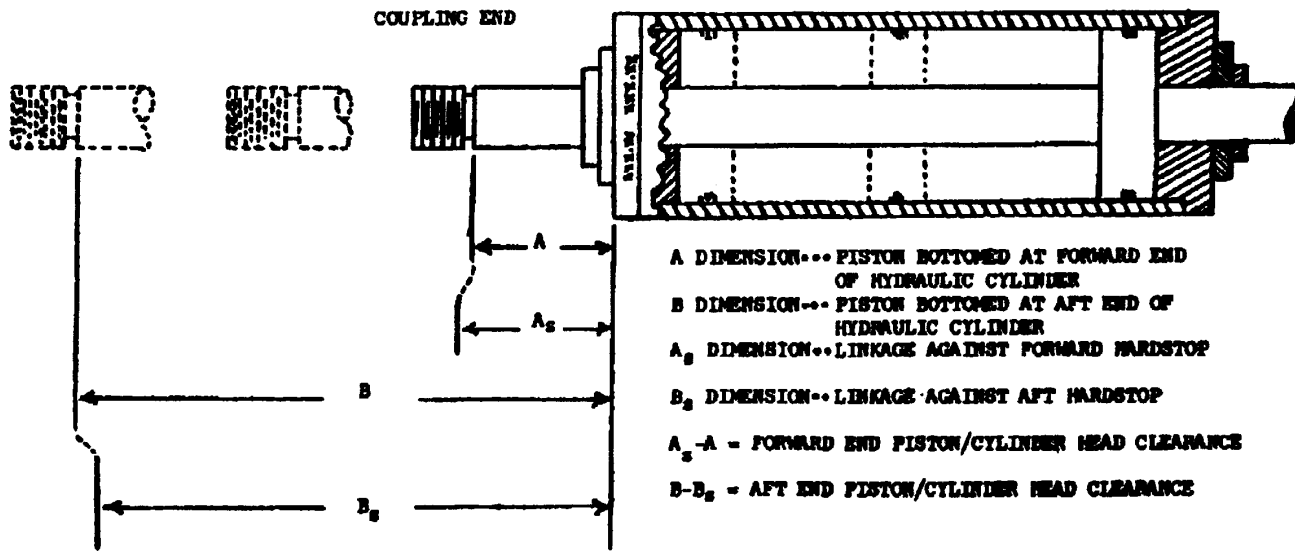

Figure 561-2-12. Piston/Head Clearance Determination

$$= 13.0 - 12.2 = 0.8$$

inch (satisfactory)

aft head/piston clearance = one-half cylinder

stroke - piston

movement (aft)

$$= 13.0 - 12.9 = 0.1$$

inch (unsatisfactory)

**NOTE**

The foregoing procedure will not determine end clearance for variations in piston rod length. Therefore, when a new piston rod is to be installed, verification must be made that the piston rod is the length required by the drawings. It should also be noted that the alternative procedure may be in error by as much as the shim thickness if a shim is installed in a coupling that was originally installed without a shim.

561-2.7.6 REMOVAL OF CYLINDER HEAD. If the foregoing checks reveal that a problem exists, investigate further as follows:

1. Move the control surface to the hardstop position and remove the cylinder head nearest to the piston

**NOTE**

Removal of the cylinder head requires prior depressurization, venting, draining, and isolation of the cylinder in accordance with standard shipboard procedures.

2. With the cylinder head removed, first measure the distance between the piston and the end of the cylinder and then measure the distance that the cylinder head extends into the cylinder. The difference between the two will equal the actual clearance.
3. Taking into account the clearance on this one end and the total distance the piston travels (hardstop to hardstop), calculate the clearance on the opposite end, using dimensions given on ship's drawings.
4. If it is concluded that a problem exists, inspect all mechanical linkage to ensure conformance to the drawing dimensions. If the cause of misalignment cannot be identified, request NAVSEA assistance or guidance to resolve the problem.

561-2.7.6.1 Torquing Of Cylinder Head Fasteners. Whenever the control surface operating cylinder heads are disturbed, it is important that the heads be reinstalled in the cylinder in a proper manner. Specifically, the fasteners that secure the heads to the cylinder body must be properly torqued. The fastener threads must be dry, clean, deburred, and lubricated with molybdenum disulfide in accordance with MIL-M-7866 (NSN 9150-00-943-6880; 203, tube). All nuts or capscrews must be evenly torqued to the appropriate values listed in [Table 561-2-5](#).

**Table 561-2-5 TORQUING OF CYLINDER HEAD FASTENERS**

Class Applicability	Cylinder Head Fasteners Torque (Ft-lbs)					
	Stern Planes		Rudder		Fairwater/ Bow Planes	
	Molykote G	Molykote P37	Molykote G	Molykote P37	Molykote G	Molykote P37
SSN 637 Class	175-200		300-325		350-375	
SSN 642	325-350		550-575		325-350	
SSN 688 Class						
(688-750)	315-330	420-440	585-615	790-830	630-660	850-890
(751-773)	315-330	420-440	585-615	790-830	475-500	640-675
(SSN 718)	200-210	270-285	585-615	790-830	630-660	850-890
SSBN 726	855-900	1160-1220	1780-1850	2400-2500	1780-1850	2400-2500
SSN 21 Class		333-407		1215-1485		390-480
SSN 774 Class		350-450		900-1100		500-600

561-2.7.6.2 Torquing of Hydraulic Cylinder Foundation Fasteners. Steering and diving hydraulic rams are secured to their foundations by various methods. These methods include: (1) fitted bolts for SSN 637 and 688 Classes (SSN 21 and 774 Classes bow planes only), (2) combinations of fitted and tapered bolts (SSN 642), (3) tension bolts (SSN 688 and SSBN 726 Classes fairwater planes ram), and (4) combinations of bolts and tapered stop blocks (SSBN 726 Class and SSN 21 and 774 Classes steering and stern diving rams). The intent of these methods is to secure the cylinder to its foundation and reduce axial movement. All of these designs rely upon fasteners which are preloaded to a specified torque. [Table 561-2-6](#) gives torque values which provide the optimum preload. In some cases, the values given exceed the torque values listed in the design drawings. Lubricate threads and surface under nut with Molykote P-37 paste. **Use of self locking nut is permitted to avoid use of cotter pin or key.** Add run-down torque of self-locking nut to tabulated values. Use hydraulic torque wrench whenever it is available or practical.

561-2.7.6.3 Inspection of Ram Axial Movement. The following provides information and guidance for inspection of hydraulic ram axial movement:



1. Inspections of axial movement of the ram should be kept to a minimum since this test applies forces to the steering/stern diving linkage which exceed the maximum hydrodynamic loads that are applied in service. Inspections should be made after overhaul or refurbishment, to verify work, and whenever URO MRC 015 is conducted to check for material degradation and wear. Inspections should be scheduled in conjunction with any tests involving application of ram load to the steering or diving gear, such as: dockside testing of the coupling, measurement of dogbone freeplay, verification of coupling tightness, and measuring tiller contact area.

**Table 561-2-6 TABLE OF TORQUE VALUES AND SELF-LOCKING NUT  
PART NUMBERS - For Ram Foundation Fasteners**

Ship/Class	Control Surface	Dwg. No.	Pc. No.	Torque [Ft-Lbs]	Self-Locking Nut Part No.
SSN 637CL	Steering	2140776	15/22	420-440	MS17829-16C
			16/23	1470-1550	MS17829-24C
	Stern	2140779	14/20	1140-1200 Note 1	MS17829-22C
			15/19	390-420	MS17829-16C
Fairwater	2141299	25	1280-1350	MS17829-24C	
SSBN 642	Steering	2437921-A	4	630-660	Note 2
			16	2660-2800 Note 1	Note 2
	Stern	2116257-D	2	230-240 Note 1	MS17829-14C
			14	430-450	MS17829-16C
		2116257-E	18	1560-1650	Note 2
Fairwater	2116866-R	7	250-270	MS17829-14C	
			17	1280-1350	MS17829-24C
SSN 688CL	Steering	4457086-A	33	1380-1450	MS17828-24C
			36	550-580	MS17828-18C
	Stern (688-750) (718) (751-773)	4457083-V	16	1600-1690	MS17829-24C
			28	740-775	MS17828-20C
			16	1600-1690	MS17829-24C
	Fairwater	4457128-S	23	970-1020	MS17828-22C
	Bow Planes	5794753-J	37	3110-3190	MS17829-28C
SSBN 726CL	Steering	4640783-F	5	2430-2970	Note 3
			6	1580-1670	Note 3
	Stern	4640786-F	5	2430-2970	Note 3
			6	1580-1670	Note 3
Fairwater	4645234-K	26	3080-3250	MS17829-28C	
SSN21	Steering	6351488	43	760	Note 3
			45	540	Note 3
	Stern	6704476 (TIP)	33	380	Note 3
					Note 3
			36	160	Note 3



**Table 561-2-6 TABLE OF TORQUE VALUES AND SELF-LOCKING NUT  
PART NUMBERS - For Ram Foundation Fasteners - Continued**

Ship/Class	Control Surface	Dwg. No.	Pc. No.	Torque [Ft-Lbs]	Self-Locking Nut Part No.
		6704477 (FLAP)	333 336	380 160	Note 3 Note 3
	Bow Planes	6404303	7	1000-1200	MS17829Z240
SSN774	Steering	6984424	20	1200-1300	Note 3
			17	250-280	Note 3
	Stern	6984428 (INBD&OUTBD)	23	600-700	Note 3
			26	240-290	Note 3
Bow Planes	7067172 7067173	127	1200-1450	MS17829Z240	

Note <sup>1</sup>Torques developed using MolyKote G lubricant.

Note <sup>2</sup>Not available in required size.

Note <sup>3</sup>Not applicable; bolt-tapped hole assembly.

2. Inspection of ram axial movement is made by mounting of dial indicator to the ram foundation and noting the movement of the ram after maximum hydraulic differential pressure is applied. Erroneous data can be obtained if the following steps are not carefully followed:
  - a. Mount the indicator base as close as possible to the pointer. Locate the pointer shaft perpendicular to the vertical surface of the ram feet or pads and as close as possible to the joint between the ram feet and the foundation and the ram axial center line. [Figure 561-2-13](#) shows the correct orientation of the dial indicator for a steering ram. If the indicator is improperly mounted or skewed to the horizontal, then inaccurate readings will result. Make appropriate adjustments in this procedure for the SSN 688 Class fairwater planes hydraulic cylinder, since it is vertically mounted at the lower cylinder head.
  - b. Using the local manual or emergency control mode, move to one of the hard stop positions, applying maximum hydraulic cylinder differential pressure with the tiller against the hard stop. Control the rate of the tiller's movement into the hard stop to avoid damaging any equipment.
  - c. Relax the applied ram pressure to the foundation by moving the tiller a small distance (1/8 inch maximum) away from the hard stop. Do not relax the ram pressure for the SSN 688 class fairwater planes hydraulic cylinder.
  - d. Zero the indicator.
  - e. Move the planes in the opposite direction and repeat steps b. and c. above. Read the indicator to obtain the total axial movement of the ram. With the exception noted above for SSN 688 class fairwater planes, it is important that the dial indicator is read after the ram pressure is relaxed, otherwise the elastic spring or deflection of the foundation fasteners and equipment will influence the data. The purpose of the test is to measure only the actual ram shift on its foundation, due to distorted bolts or bolt holes.
3. Inspection criteria for maximum allowable axial movement of the hydraulic ram are given by paragraph [561-2.7.6.4](#) below. Movement in excess of these amounts indicates the onset of rapidly increasing wear, insufficient torque or both. If proper torquing does not reduce axial movement to the maximum allowable value then restore cylinder mounting fasteners and bolt holes to drawing requirements.

4. Documentation of ram axial movement shall be made using Maintenance Requirement Cards (MRC) for SRA/ERP availabilities and Maintenance Standards (MS) (formerly Technical Repair Standards (TRS)) for regular overhauls or depot availabilities.
5. It is important that the foundation fasteners are properly torqued to maintain the maximum preload of the fasteners and clamping force of the foundation to the cylinder. See paragraph 561-2.7.6.2. If the inspection of relative motion shows values in excess of the maximum allowed of Table 561-2-7 then the torque of the fasteners should be checked and the inspection redone. This may avoid the need for unnecessary repair action.

561-2.7.6.4 Hydraulic Ram Movement. Relative motion between a hydraulic cylinder and its foundation may occur due to one or more of the following reasons:

- a. Insufficient fastener preload.
- b. Elastic bending and shear deflection of the fitted bolts and/or tapered pins in way of shim pads.

561-2.7.6.5 Acceptable Ram Movement. Table 561-2-7 lists the amount of relative motion in the direction of ram travel that is acceptable on new installations and on existing installations that have been refurbished to design dimensions and tolerances. It also tabulates the maximum allowable cylinder to foundation relative movement for in-service submarines.

561-2.7.6.6 SUPERBOLT . See definition for multi-jackbolt tensioner in NSTM Chapter 075, Fasteners, paragraph 075-2.8.4:

**MULTI-JACKBOLT TENSIONER.** Multi-jackbolt tensioners (see Figure 075-2-2) are a solution to a major problem with large diameter fasteners: how to preload the fastener. Conventional fasteners are preloaded by tightening the nut, which can be difficult when the fastener is large or access to the fastener is restricted. Multi-jackbolt tensioners are preloaded by extending the jackbolts in the nut, which can be done using hand tools.

**Description.** Multi-jackbolt tensioners are designed as direct replacements for hex nuts. The tensioner is threaded with a main thread similar to a nut, but usually with a circular rather than hex cross-section. The tensioner is provided with a hardened washer which goes on before the tensioner. The tensioner is equipped with multiple jackbolts (hex or socket head configuration) which encircle the main thread. Once the tensioner is positioned, actual tensioning of the bolt or stud is accomplished by torquing the jackbolts, which bear against the hardened washer.

**Benefits.** The major benefit of multi-jackbolt tensioners is that they can create very high fastener preloads using normal hand tools. Their simpler installation and removal can be completed using fewer workers and less time than is needed to tighten and loosen large hex nuts. Experience has shown that once properly torqued, pre-stressed tensioners will remain tight and not loosen on vibrating, pulsating and reciprocating equipment.

561-2.7.7 CYLINDER PISTON LOCKING DOWEL INSTALLATION. Except for the addition of an alignment shim, the cylinder piston configuration used in steering and stern diving hydraulic cylinders without tailshafts for SSN 637 class and other ships with similar design cylinders is shown in Figure 561-2-14(a). In this configuration, the piston and aft dashpot dasher are secured by the forward dasher, which is threaded onto the piston rod at assembly. The forward dasher is locked onto the piston rod by an axial locking dowel at the interface of the dasher and the piston rod ends. The locking dowel is then held in place by a retaining plate secured to the end of the piston rod.

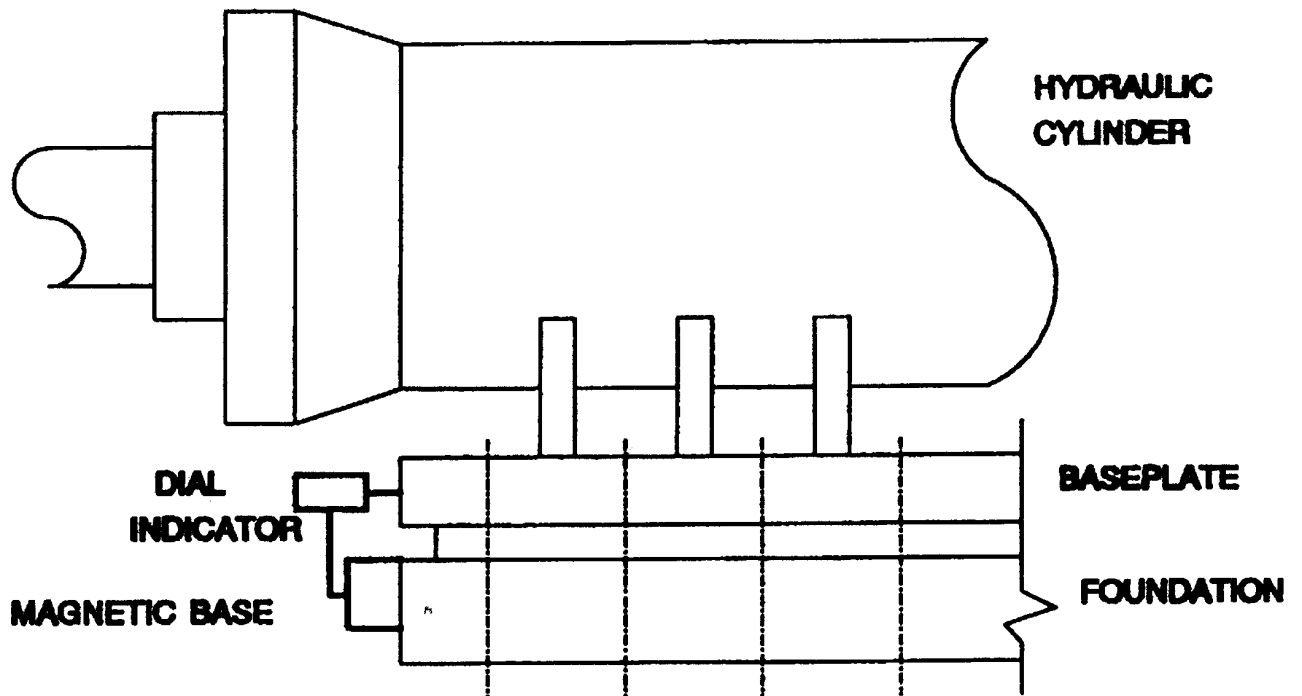

Figure 561-2-13. Hydraulic Ram Axial Movement Inspection

Table 561-2-7 HYDRAULIC RAM MOVEMENT

CLASS	MAXIMUM ALLOWED MOVEMENT (IN)	
	DESIGN	IN-SERVICE
Pre-688	0.005	0.020
688 <sup>Note 1</sup>	0.005	0.020
726	<sup>Note 2</sup>	<sup>Note 2</sup>
21	<sup>Note 2</sup>	<sup>Note 2</sup>
774	<sup>Note 3</sup>	<sup>Note 3</sup>

<sup>Note 1</sup>Fairwater = 0.002" for both design and in-service.

<sup>Note 2</sup>Measurements are not required due to the design of mountings and hard stop arrangement.

<sup>Note 3</sup>Measurements are not required for stern planes and rudder due to the design of the mountings and hard stop arrangement.

561-2.7.7.1 Locking Dowel Misalignment. After rework, the locking dowel hole in the dasher sometimes goes past the portion of the locking dowel hole in the piston rod when the dasher is torqued onto the piston rod. This misalignment can be the result of previous improper assembly or can be caused by machining the faces of the aft dasher, piston, or forward dasher to obtain the surface finish identified in Maintenance Standards (MSs) (formerly Technical Repair Standards (TRSs)). To prevent misalignment, no machining should be done on the faces of the piston or dashers unless required to ensure proper seating of the components or to eliminate surface imperfec-

tions that could affect cylinder operation. If misalignment occurs, alignment shall be corrected by shimming or by relocating the piston locking dowel as described in paragraphs 561-2.7.7.2 through 561-2.7.7.3.

561-2.7.7.2 Shimming to Obtain Locking Dowel Alignment. The more preferable method for correcting the alignment of the holes for the locking dowel is through the use of a shim. Since the forward dasher has advanced too far under torque, the installation of a shim of proper thickness between the piston and forward dasher will realign the dowel holes in the rod and forward dasher. See Figure 561-2-14 a.

561-2.7.7.2.1 The thickness of the shim shall be as required to produce proper dowel hole alignment. The proper thickness can be determined by torquing the dasher against feeler gages or laminated shim stock inserted between the dasher and the piston. The shim shall be made from nickel-copper sheet, QQ-N-281 Class A, or Corrosion-Resistant Steel (CRES) sheet, Condition A, Class 304, 304L, 316 or 316L per QQ-S-766. Shim material of the required thickness is rarely available from the supply system and laminated shim stock is not to be used for permanent installation. The thicker standard sheets listed in Table 561-2-8 can be used, however, by skim-cutting the face of the forward dasher. The face of the dasher to be cut should be the one next to the piston.

561-2.7.7.2.2 The inside diameter of the shim shall be .003/.005 inch larger than the diameter of the piston rod land on which the shim is to be installed. The outside diameter of the shim shall be the same as the outside diameter of the forward dasher. After the shim is inserted, the dasher shall be torqued as indicated on the applicable drawing. Shims in excess of the sheet thicknesses as listed in Table 561-2-8 should not be used.

561-2.7.7.3 Piston Locking Dowel Relocation. A less preferable method for correcting misalignment of the dowel locking hole is shown in Figure 561-2-14. In this method, a new locking dowel hole is drilled at the dasher drive hexagon point 120 degrees from the existing dowel hole after the dasher has been torqued onto the piston rod. The dowel hole may be redrilled (as shown in Figure 561-2-14 b.) only twice. Subsequent misalignment will require correction by the method given in paragraph 561-2.7.7.2 or by replacement of the piston rod. The dowel hole shall be drilled in accordance with requirements of the applicable drawing.

561-2.7.8 STERN DIVING GEAR DIVE LIMIT STOP MECHANISMS. The stern diving rams of SSN688 class (except SSN 718) and SSBN726 class are equipped with hydraulically actuated dive stop mechanisms which prevent plane movement beyond a preset angle. The stop mechanisms on SSN688 and SSBN726 consist of a cross-shaped stop keyed onto the ram tailrod, and a rotating striker plate, with a cross-shaped opening, which is mounted to a housing on the forward end of the ram.

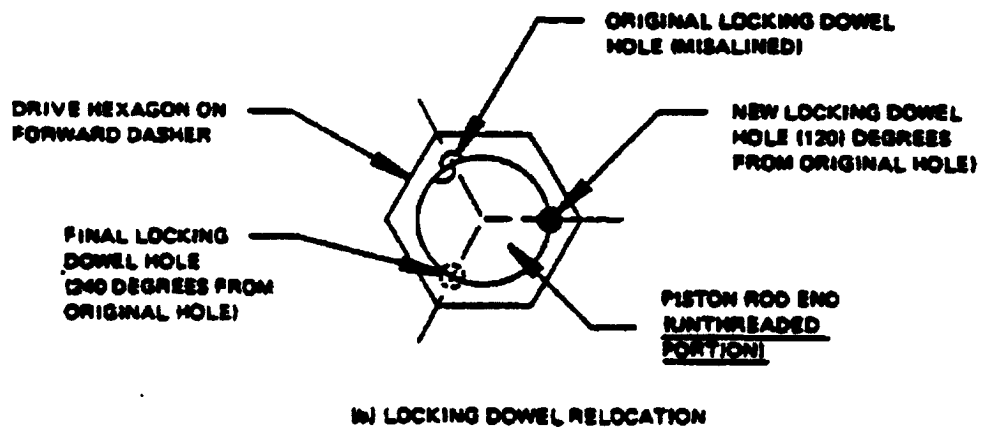
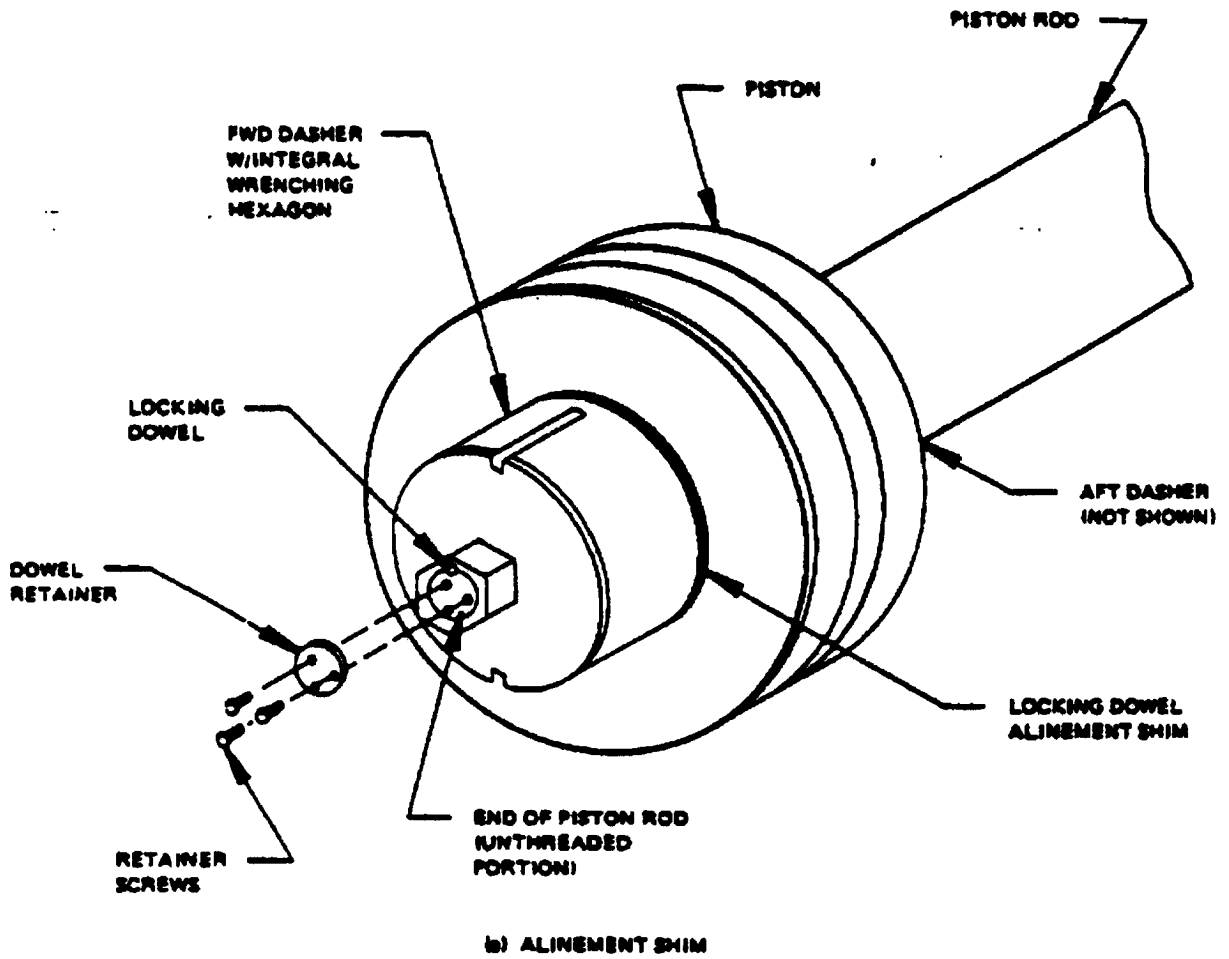

Figure 561-2-14. Hydraulic Cylinder Piston Alinement and Locking Dowel Relocation

**Table 561-2-8 SHEET STOCK MATERIAL FOR CYLINDER PISTON ALINEMENT SHIMS**

Thickness	Nickel Copper QQ-N-281 Class A	CRES Class 304, Condition A
.019	9535-00-767-2064	9515-00-204-4536
.025	-----	9515-00-204-4558
.031	9535-00-232-2307	9515-00-204-4556
.038	9535-00-234-2161	9515-00-204-4533
.050	9535-00-232-2308	9515-00-204-4528
.063	9535-00-234-2166	9515-00-204-4529

561-2.7.8.1 SSN688 Class and SSBN726 Class Ram Stop Operation. During dive stop engagement the striker plate is rotated 45 degrees to interfere with tailrod motion. During dive stop disengagement the striker plate rotates to a position which allows passage of the tailrod stop with a clearance of 1/4 inch on each side of the four stop arms. Having passed into the striker plate, the tailrod stop prevents the striker plate from rotating into its closed position, which prevents the planes from being trapped at a dive angle greater than the preset limit value.

561-2.7.8.2 Correction of SSN688 Class Tailrod Stop Misalignment. A significant difference exists between the stop assemblies on SSN688 class and SSBN726 class. The SSBN726 class tailrod stop is captured throughout its travel by a guide mounted on the striker plate housing. If the striker plate on a SSBN726 class is properly oriented when disengaged, the tailrod stop will be guided into the striker plate with proper clearances. The SSN688 class stop assembly has no such guide prior to entry into the striker plate and relies on the axial key in the tailrod to establish its orientation. If sufficient misalignment exists between a SSN688 class tailrod stop and its disengaged striker plate, interference with tailrod motion and damage to the stop or striker plate can result when the stop enters the striker plate. If a misalignment of the stop to the striker is noted which produces a clearance of less than 3/16 inch on either side of any of the four stop arms (see [Figure 561-2-15](#)) corrective action must be taken.

561-2.7.9 SSN637 CLASS FAIRWATER DIVING GEAR DIVE STOP PLATE INSTALLATION. Although not in the class design, the fairwater diving gear hydraulic ram cylinders of some SSN637 class submarines have a special stop plate mounted on top of the packing gland of the main cylinder upper head. The purpose of this plate is to provide a stop for the under-ice lock ring to prevent a fairwater plane dive jam by limiting the travel in emergency mode to approximately 20-1/2 degrees. The configuration of these stop plates are similar to that shown on drawing number SSN637-518-2663781 Revision D, Detail 8-A in zone 8-D. When encountered, this stop feature shall be retained.

## 561-2.8 STEERING AND DIVING MECHANICAL GEAR

561-2.8.1 TYPICAL STEERING AND DIVING GEAR ARRANGEMENTS. For each control surface, the power developed by the hydraulic cylinder is transmitted through connecting rods to a tiller that, in turn, causes the control surface stock to rotate. A typical steering and stern diving gear arrangement is shown in [Figure 561-2-16](#). The forward diving planes on earlier design submarines are located in the fairwater (sail) and are known as fairwater planes. Newer designs have relocated these planes on the hull forward of the fairwater and are called bow planes or Retractable Bow Planes (RBP) as they are designed to retract into the hull until they are faired flush with the outer hull. A typical fairwater diving plane arrangement is shown in [Figure 561-2-17](#) and a typical bow plane arrangement is shown in [Figure 561-2-18](#). Fairwater, bow and stern plane stocks are supported

by plain-sleeved bearings or spherical-sleeved bearings. The rudder stocks are retained by spherical-sleeved bearings, with the weight of the rudder being supported by thrust washers (carrier bearings). The bearings originally installed on most submarines were metallic and required periodic greasing. NAVSEA has approved the use of self-lubricated bearings for most submarine applications (see [para. 561-2.8.13.12](#)).

**561-2.8.2 STEERING AND DIVING LINKAGE COUPLING.** In most installations, the steering and diving hydraulic cylinder piston rod is connected to the guide cylinder (or crosshead) connecting rod by an internally threaded coupling secured in position by two locking bolts as shown in [Figure 561-2-19](#). Also, in most assemblies, a shim is installed between the two rod ends. The purpose of the shim is to provide a variable dimension which aids in the process of alining existing locking bolt holes in the coupling and the rods. Discussions herein are applicable to the following submarines having couplings similar to that shown in [Figure 561-2-19](#):

SSBN 726 Class

SSN 637 Class

SSN 688 Class

SSN 642

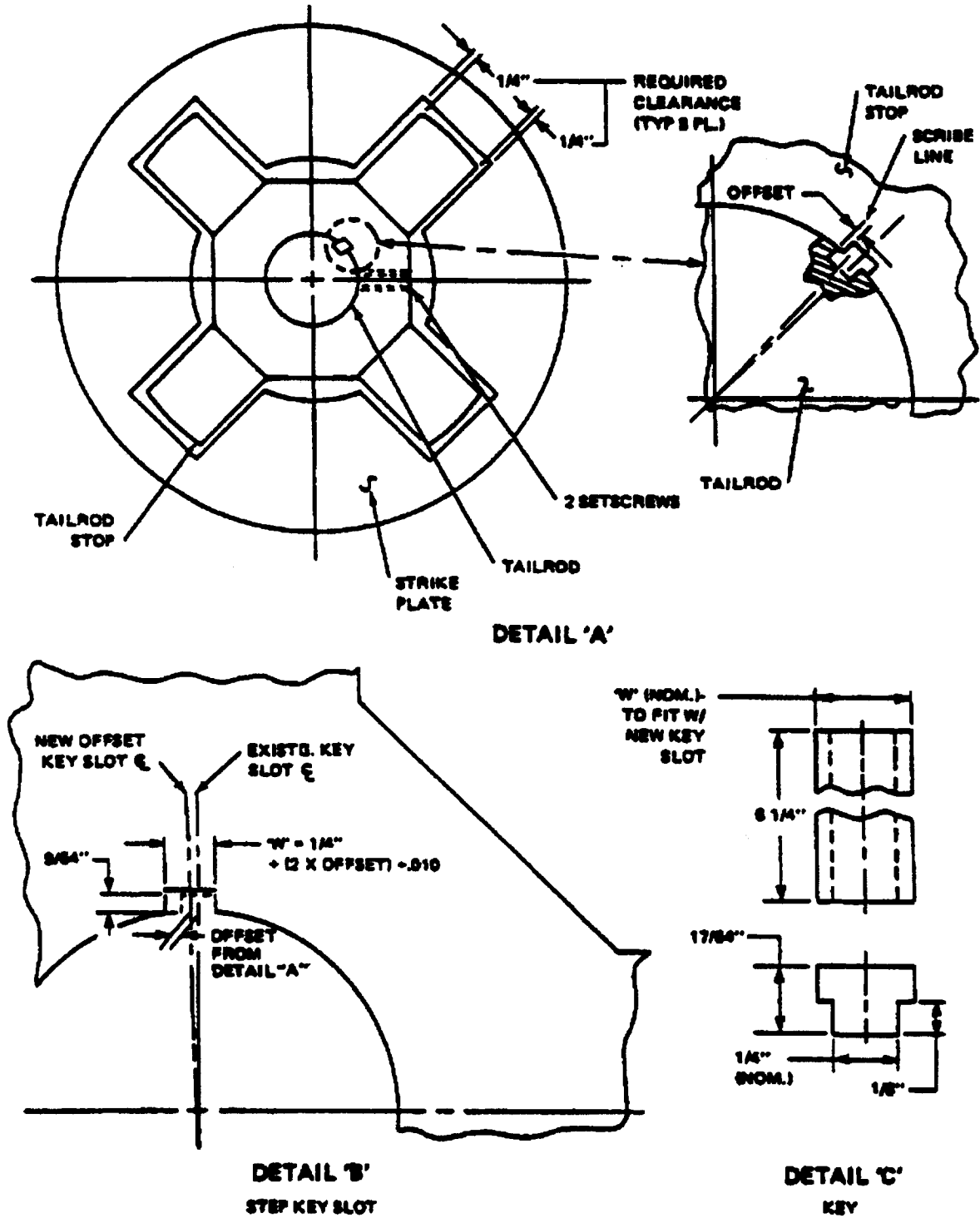

Figure 561-2-15. Step Key Slot



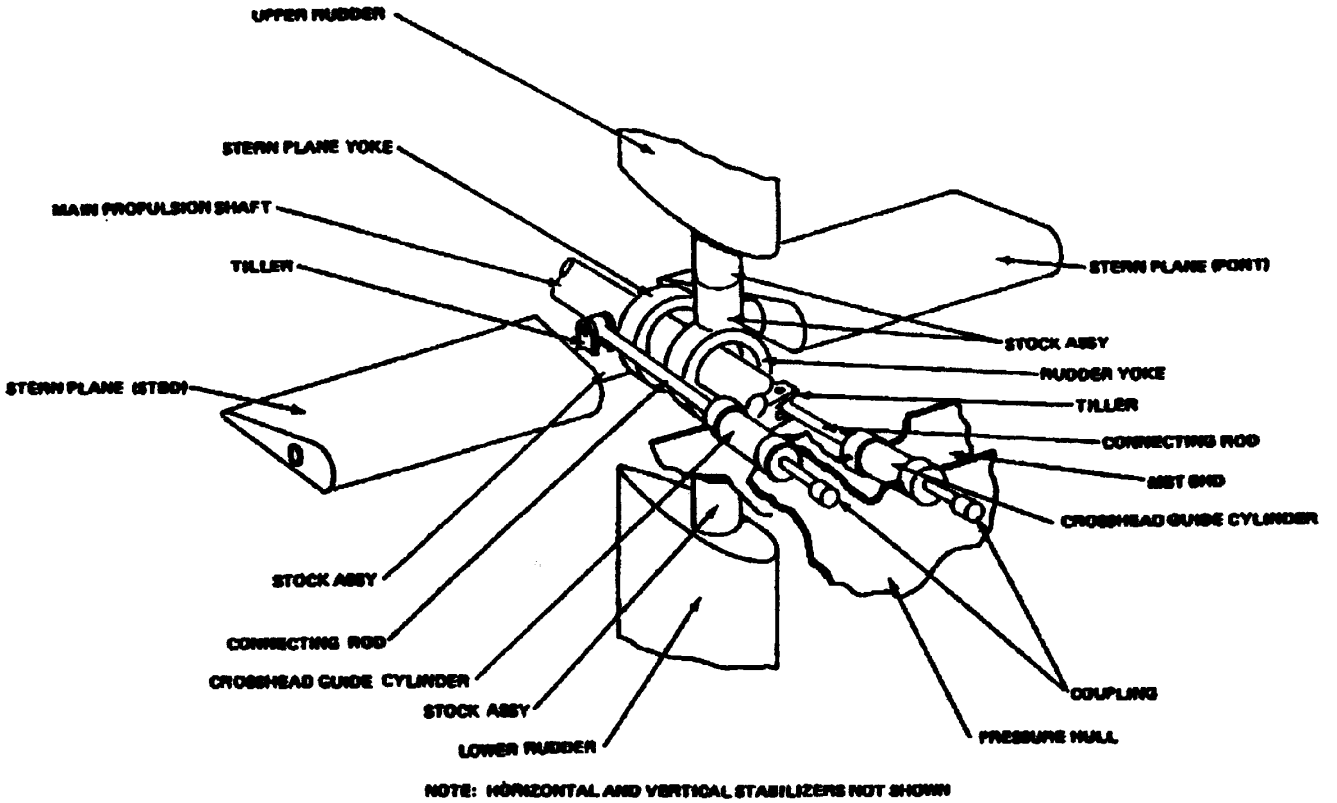

Figure 561-2-16. General Arrangement of Steering and Stern Diving Gear

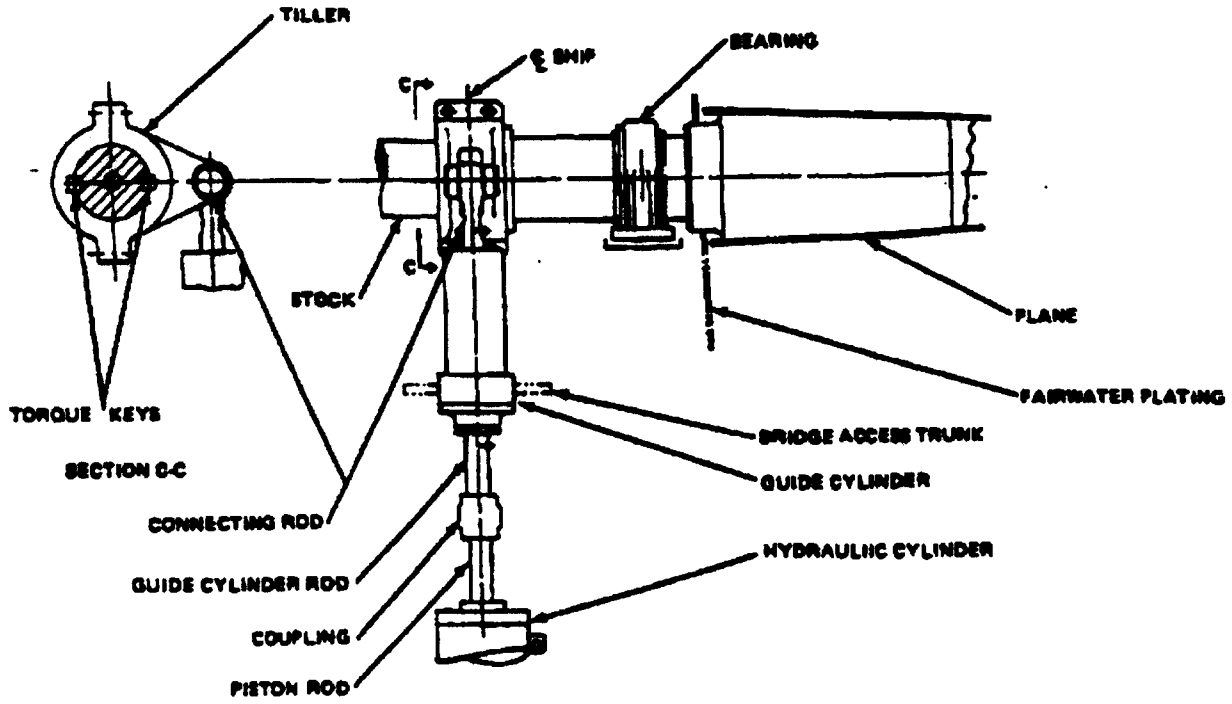

Figure 561-2-17. Fairwater Diving Arrangement

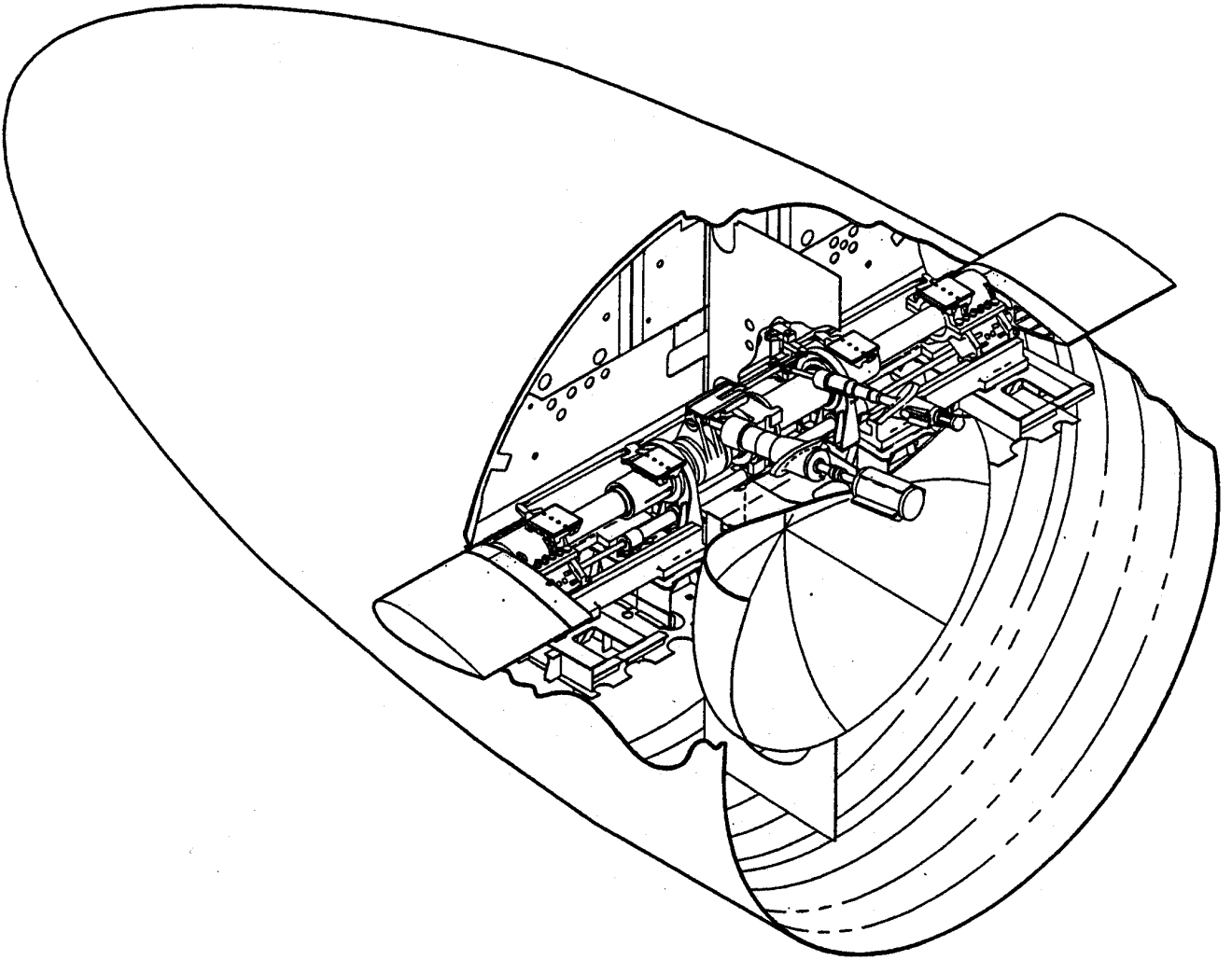

Figure 561-2-18. SSN 688 Class Retractable Bow Planes Arrangement (Extended Position)

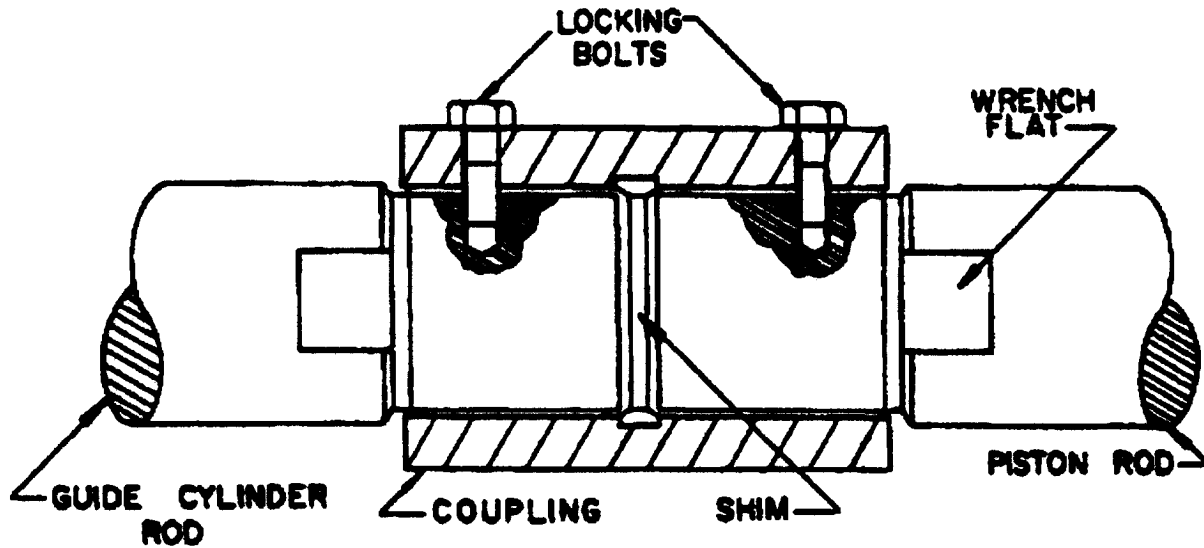

Figure 561-2-19. Coupling Arrangement

561-2.8.2.1 Coupling Installation Requirements. This procedure is followed whenever a coupling assembly consisting of either existing or new components is installed or reassembled. It varies from the procedures given by steering and diving assembly drawings. Assemble the coupling as follows:

1. Verify that the through hull rod and the hydraulic cylinder piston rod are in proper alignment or realine as necessary. (See paragraph 561-2.8.4.2).
2. Prior to installing the coupling on the rods, apply a thread lubricant (molybdenum disulfide) to the threads on both rods to prevent galling.

#### NOTE

During installation, the coupling is first started on the through hull connecting rod one turn prior to threading on the piston rod. This provides room for the shim and results in proper locking bolt hole alignment.

3. Thread coupling on one rod, one complete thread before engaging the other rod to avoid cross-threading. Hold the rods fixed and rotate the coupling to draw both rods into the coupling simultaneously. This will prevent damage to any thread locking devices in the ram or guide cylinder piston (crosshead).
4. Torque coupling to the torque value given by [Table 561-2-9](#)

#### CAUTION

**Control the rate of the tiller's movement into the hard stops to avoid damaging any equipment.**

5. Exercise the coupling by applying the maximum force of the hydraulic cylinder to the coupling assembly. Move the tiller into contact with each hard stop at least three times. After contacting the hard stop, maintain hydraulic cylinder load against the hard stop for a brief period of time (5-10 sec). Use available 3000 psi hydraulic power source.

#### NOTE

In some cases, the torque values shown in [Table 561-2-9](#) may exceed the torque values on the ship's drawings.

6. Verify coupling has not loosened after step 5 by attempting to retorque coupling to required torque value (see [Table 561-2-9](#)).
7. If coupling rotates during step 6, repeat steps 5 and 6 until step 6 can be performed without a rotation of the coupling.

**Table 561-2-9** TABLE OF TORQUE VALUES FOR COUPLING

Ship Applicability	Coupling Torque Value in Ft-Lb (-0 ft-lb) (+200 ft-lb)		
	Stern Planes	Rudder	Fairwater/ Bow Planes
SSN 642	2000	2000	2000
SSN 688 Class	2000	2000	2000
SSBN 726 Class	3000	3000	3000
Other Than Above	Drawing	Drawing	Drawing
SSN 21 Class	750-1000	2500-3000	CAPSCREWS 325-350
SSN 718	2000	2000	2000
SSN 774 Class	375-450	2600-3100	CAPSCREWS 360-440

8. Install coupling locking bolts and torque to the required value. If the coupling assembly was previously installed, careful attention must be paid to the realining of the locking bolt holes. If these holes are not properly aligned after torquing, the shim between the two rods must be resized (See [paragraph 561-2.8.2.7](#)) and the entire procedure must be repeated.

**NOTE**

SSBN 726 Class ships have a unique coupling locking bolt configuration, which has adjustable alignment plugs on both ends of the couplings. After the coupling has been torqued to the proper value, the locking bolt holes should be completely visible in the holes for the plugs in the coupling. If the holes in the rods are not completely visible through the coupling, the joint will need to be re-shimmed (see [paragraph 561-2.8.2.5](#)). The original plugs can now be checked for alignment of the plug hole with the hole in the rod. If the holes do not line-up, new plugs will have to be manufactured, by transferring the centerline of the hole in the rod to the new plug.

9. For a new coupling assembly (consisting of either a new coupling or rods or both), drill locking bolt holes in new coupling/rods as necessary and install locking bolts. For a used coupling assembly, resize shim and assemble coupling to maintain required torque value. For SSBN 726 Class ships with locking bolt plugs, manufacture and install new plugs to align locking bolts.

561-2.8.2.2 Coupling Locking Bolts. Once installed, the locking bolts should be lockwired in accordance with MS-33540 with lockwire conforming to MS-20995. Lockwire material can be either monel or CRES.

**CAUTION**

**More than one tapped hole in the rod is prohibited without NAVSEA approval as this could significantly reduce the strength of the rod. Proper coupling assembly as discussed herein is mandatory.**

561-2.8.2.3 Coupling Disassembly. When the coupling must be removed from the linkage in order to perform maintenance or repair of the hydraulic cylinder or mechanical linkage, proceed as follows:

1. Prior to starting disassembly, position the affected control surface to the neutral (zero degree) angle position and, if possible, block the control surface in that position to prevent further movement. When the diving planes cannot be blocked in this manner, position these planes in the hard rise (fairwater) or hard dive (stern diving) position (mechanical hardstop) by using either the local or emergency control mode. This will prevent the diving planes from uncontrolled movement when the coupling is disengaged.
2. Secure all hydraulic power to the operating cylinder by shutting the isolation valves to the cylinder.
3. Vent and drain both ends of the hydraulic cylinder. Disconnect all linkage, such as feedback transmitter linkage, from the coupling.
4. Remove the two locking bolts from the coupling.
5. Prior to further disassembly, scribe reference lines (axially in line with the tapped holes for the locking bolts as shown in [Figure 561-2-20](#)) on each rod and the vertical faces (ends) of the coupling. Sealing wax may be used as a base on which to scribe the marks. The tapped holes on the rod ends will be obscured from view within the coupling as they near their final positions during reassembly and the reference lines will be of considerable value in maintaining the orientation of the holes.
6. Prior to further disassembly, determine the proper shim thickness (paragraph [561-2.8.2.6](#)) and make this information available for use during reassembly.
7. Mark the hydraulic cylinder end of the coupling so it can be easily identified for certain shim fitting procedures and reassembly.

---

**WARNING**

---

**Upon coupling removal, all personnel shall stay clear of the space vacated by the coupling. Wave action and currents can exert forces sufficient to move the control surfaces and such movement can result in the guide cylinder rod impacting against the piston rod. Forces are severe enough to cause loss of life or dismemberment. The general area shall be posted as a danger area.**

---

**CAUTION**

---

**Cylinder piston rod rotation during maintenance of couplings may subject equipment to undue strain and shall be avoided unless otherwise specified.**

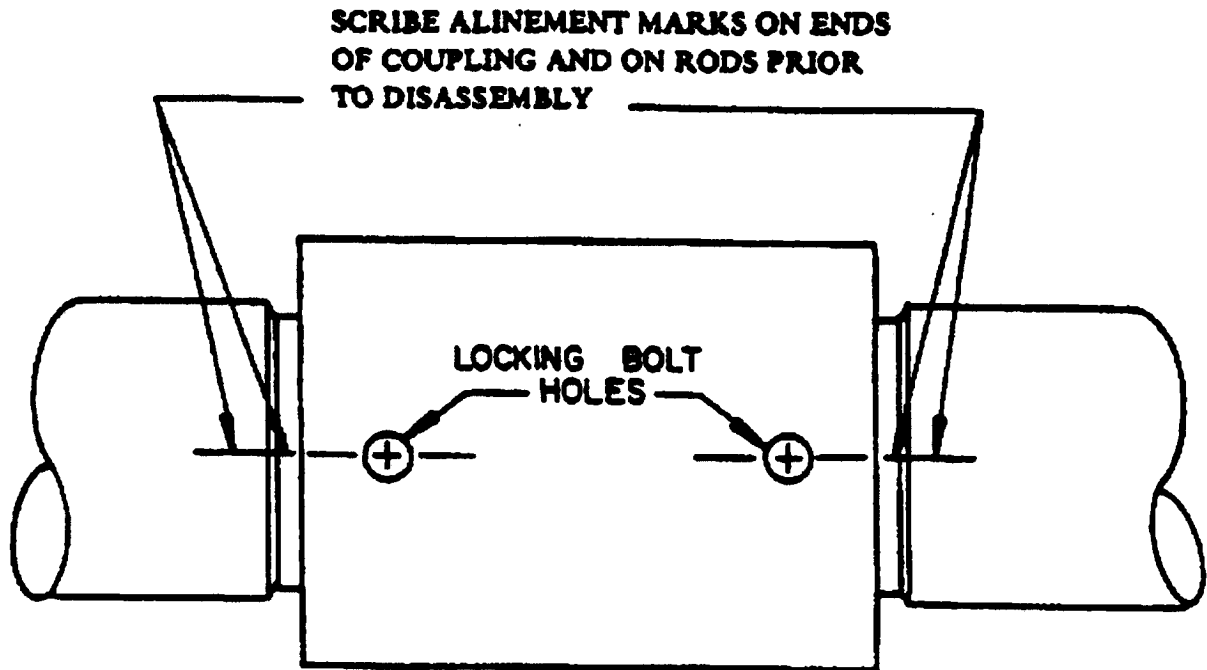

Figure 561-2-20. Location of Alinement Marks

8. Remove the coupling from the linkage.

561-2.8.2.4 Rod Rotation. When installing, disassembling, or reassembling coupling, do not allow the through hull connecting rod to rotate as this places undue stress on the yoke pin and the crosshead pin.

561-2.8.2.4.1 When installing, disassembling, or reassembling coupling, do not allow the hydraulic cylinder piston rod to rotate as this may place undue stress on piston to piston rod fastening screws.

561-2.8.2.5 Shim Fitting. Shim fitting becomes necessary when it is impossible to align the coupling clearance holes and the tapped holes in the piston and through hull connecting rods following torquing of the coupling. In this case, alinement is achieved by changing the thickness of the shim. Under no circumstances should additional holes be added to either the coupling or the rods. If great difficulty is encountered in obtaining the shim thickness necessary in order to align the holes, the coupling hole may be slightly elongated in the direction of the coupling axis, to allow accommodation of the bolt. An elongation of up to 1/8 inch is permissible if the elongation blends smoothly with the original hole and has no corner ridges or cusps. Shims should be machined from the same material as the piston rods. The diameter of the shim should be 1/8 inch less than the ID of the coupling.

561-2.8.2.6 Determining the Thickness of a Replacement Shim. If a coupling assembly, complete with an existing shim and locking bolts, requires reshimming, the thickness of the new shim will be equal to the thickness of the old shim plus the required increase in thickness as determined by the following procedure:

1. With the original shim still in the coupling, align the tapped holes in the rods with the clearance holes in the coupling (the assembled condition with the locking bolts removed).
2. Attach a dial indicator to one of the rods with the indicator plunger in contact with the end of the coupling.
3. Torque the coupling to a value per [Table 561-2-9](#), making certain that neither rod rotates.

4. Double the movement measured on the dial indicator (because both rods move into the coupling) and add this value to the measured thickness of the existing shim to calculate the thickness required for the new shim.

561-2.8.2.7 Determining the Thickness of a New Shim. A coupling that was initially installed with the piston rod and through hull connecting rod in direct contact (no shim installed) is a special case. Although only few in number, such installations do exist. If clearance holes and tapped holes in these installations are in alignment after the coupling is torqued to a value per [Table 561-2-9](#), a shim does not have to be installed. However, since the original installations did not specify a torque value, it is quite likely that the currently specified torque will necessitate use of a shim. If so, determine the thickness of the required shim as follows:

1. Aline the tapped holes in the rods with the clearance holes in the coupling (the assembled condition with the locking bolts removed).
2. Attach a dial indicator to one of the rods, with the indicator plunger in contact with the end of the coupling.
3. Torque the coupling to a value per [Table 561-2-9](#), making certain neither rod rotates.
4. Record the movement measured on the dial indicator.
5. Since a very thin shim is difficult to manufacture, it is suggested that the shim installed have a thickness of  $1/P$  inches plus twice the measurement obtained in step 4. ( $P$  represents the threads per inch in the coupling and  $1/P$  is the movement of the rod relative to the coupling on one complete rotation.)
6. Elongate the hole on the piston rod end of the coupling  $1/P$  inches toward the nearest edge of the coupling. Elongation must be accomplished prior to reassembly.

#### NOTE

During installation, the coupling is first started on the through hull connecting rod one turn prior to threading on to the piston rod. This provides room for the shim and results in proper locking-bolt hole alignment. This procedure is also applicable during coupling reassembly.

561-2.8.2.8 Maximum Allowable Shim Thickness Changes. Addition/deletion of a shim or installation of a thinner/thicker shim in the coupling assembly changes the total length of the mechanical linkage between the control surface stock (yoke assembly) and the hydraulic cylinder piston. The primary concern regarding this change is that the clearance between the piston and the hydraulic cylinder head (when the control surface is in the hard over, mechanical hard stop, position) is affected. Shipbuilding specifications require that the cylinder piston clear the ends of the cylinder by at least  $1/4$  inch when the control surfaces are against the hardstops. Most cylinders have been designed to provide clearance of  $1/2$  inch or more. Therefore, it is recommended that if the thickness of the shim to be installed approaches  $1/4$  inch more, or  $1/4$  inch less, than the shim thickness originally specified on the applicable class drawings, the piston/head clearance be verified as outlined in paragraph [561-2.7.5.1](#).

561-2.8.2.9 Reassembly of Couplings. When reassembling the coupling, observe the same precautionary measure cited for coupling disassembly (paragraph [561-2.8.2.3](#)). To prevent the shim from falling out of its intended position once the coupling is started on both rods, secure the shim to one of the rods, using a small patch of lightly applied contact cement. In some installations, a flathead machine screw is used to hold the shim to one of the rods. In these installations be sure that the screw is tightened in place before proceeding. The procedure for assembling a coupling will differ according to the initial coupling installation and the maintenance performed, but in all cases the requirements of section [561-2.8.2.1](#) will apply. Procedures for five specific cases are as follows:

#### CAUTION

**Cylinder piston rotation during assembly of couplings may subject equipment to undue strain and shall be avoided unless otherwise specified.**



1. Case 1 - Original installation did not include shim. The dimensions of the new shim should be those determined in accordance with the instructions in paragraph 561-2.8.2.7. Thread coupling on to the rods per paragraph 561-2.8.2.1. Verify proper orientation of the tapped holes in the two rods, using the scribed lines (paragraph 561-2.8.2.3). Holding both rods from rotating, torque the coupling to a value per Table 561-2-9, stopping when the locking bolt clearance holes align with the tapped holes in the rods. If alignment cannot be achieved with torque within the specified range, redetermine the proper shim thickness and repeat the above process until alignment is obtained. (See paragraph 561-2.8.2.7 for requirements.) Install locking bolts in accordance with paragraph 561-2.8.2.2.
2. Case 2 - Original installation included shim. The dimensions of the new shim should be those determined in accordance with the instructions in paragraph 561-2.8.2.6. Secure the shim to one rod as discussed previously. Thread coupling on to the rods per paragraph 561-2.8.2.1. Verify proper orientation of the tapped holes in the two rods, using the scribed lines (paragraph 561-2.8.2.3). Holding both rods from rotating, torque the coupling to a value per Table 561-2-9, stopping when the locking bolt clearance holes align with the tapped holes in the rods. If alignment cannot be achieved with torque within the specified range, redetermine the proper shim thickness and repeat the above process until alignment is obtained. (See paragraph 561-2.8.2.7 for requirements.) Install locking bolts in accordance with paragraph 561-2.8.2.2.
3. Case 3 - Piston rod replaced. Install piston rods in accordance with applicable system drawings and complete the assembly per paragraph 561-2.8.2.1.
4. Case 4 - Through hull connecting rod replacement. Install through hull connecting rods in accordance with applicable system drawings and complete the assembly per paragraph 561-2.8.2.1.
5. Case 5 - Coupling replaced. If a new coupling is to be installed, it shall be furnished with locking bolt clearance holes not drilled since these holes must be aligned to the existing locking bolt holes in the piston rod and the through-hull connecting rod. Using micrometers, measure the axial distance from the centerline of the locking bolt hole in each rod to some prominent point on the rod which will remain accessible when the coupling is installed. Secure the original coupling shim to the end of one rod. Thread coupling on to the rods per paragraph 561-2.8.2.1. While holding both rods from rotating, torque the coupling to a value per Table 561-2-9, stopping when the scribe lines (See paragraph 561-2.8.2.3, subparagraph 5) on the two rods are in axial alignment. (Reshim if necessary. Ensure that the shim used will provide proper piston to hydraulic cylinder head clearance.) Establish scribe lines on the end faces of the coupling using the scribe lines on the rods. Establish axial centerline locations for the locking bolt clearance holes on each end of the coupling. Using the micrometer dimensions obtained earlier, establish the fwd-aft location of the locking bolt clearance holes on each end of the coupling. Disassemble the coupling and drill the locking bolt clearance holes. Reassemble the coupling in accordance with paragraph 561-2.8.2.9, subparagraph 2 Case 2 and paragraph 561-2.8.2.1.

561-2.8.2.10 Additional Comments Applicable to Reassembly. Precautionary information relative to rotating the piston rod on a number of ship classes is given in paragraph 561-2.8.2.4.1. On ships where assembly conditions necessitate piston rod rotation, the cylinder head should be removed following coupling assembly and the piston locking fasteners should be inspected for integrity. If, during reassembly procedures, both locking bolt holes are out of alignment an equal amount, proceed as follows:

1. Thread coupling on to the rods per paragraph 561-2.8.2.1.
2. After assembling the coupling, verify the existence of proper clearance between the piston and the cylinder heads as specified in paragraph 561-2.7.5.1.
3. Replace and realign all feedback transmitter linkage and mechanical angle indicators.

4. Inspect all mechanisms for ruggedness, proper clamps, presence of all set screws, and security of all pins and fasteners.
5. Conduct an operational test (or URO/MRC-16 or 019 as applicable) of the complete system to verify proper functioning.

561-2.8.3 STEERING AND DIVING CONNECTING RODS. Two connecting rods are used in most installations. One, the through hull connecting rod, is connected to the hydraulic cylinder by the coupling and to the crosshead piston with a threaded connection. This rod penetrates the pressure hull and transmits the linear force generated at the hydraulic cylinder to the crosshead piston. Alinement of this rod with the hydraulic cylinder piston rod is very important, because wear of bearing surfaces and packing rings in the guide cylinder cover and hydraulic cylinder head will accelerate with misalinement. For further information on the subject refer to paragraph 561-2.8.4.1. The other connecting rod usually found in steering and diving gear is commonly referred to as the dogbone because of its shape. This rod is located outboard of the pressure hull. It is connected to the crosshead piston and tiller by means of pins. This arrangement allows for rotary motion at the crosshead piston and tiller, as the tiller swings through an arc while turning the control surfaces. For a typical arrangement of these two rods refer to Figure 561-2-16 and Figure 561-2-17.

561-2.8.3.1 Loose Coupling. During normal operation coupling joints between the hydraulic piston rod and the through-hull rod become worked and occasionally loosen. This loosening occurs when the rods are no longer in tight compression with the shim located between the rods and may result in noise and undesirable mechanical working of the joint. To prevent this from happening the torquing procedure was revised to incorporate working the joint during the torquing process. All couplings currently in service may not have been torqued in this manner. If a loose coupling is detected, retorque the coupling following the procedures provided in paragraph 561-2.8.2.1.

561-2.8.3.2 Removal of SSN 688 Class Through Hull Connecting Rods. Removal of the steering and stern diving through hull connecting rods through the engine room access is impractical because of the long length of the rod. NAVSEA Dwg. 100-5789854 provides guidance and details for removal of these rods using access cuts in the ship's stern section.

561-2.8.4 CONNECTING ROD LUBRICATION. Since rotary motion exists at the tiller and crosshead (piston or slide) pins, bushings are installed in the outboard (dogbone) connecting rod. Various SHIPALTS install bushings in tiller arms where the original design does not provide this feature. Some submarine Maintenance Standards (MSs) provide for installing bushings in guide pistons (crossheads) as a method of restoring piston wrist pin bores that are enlarged due to wear or repair machining. Thrust washers are installed between the bearing faces of the outboard connecting rod and the adjoining surfaces on tillers and pistons. On most submarine classes, each end of the connecting rod receives lubrication via either local grease fittings or a centralized system using manifolds or distribution valves located within the pressure hull. Non-metallic self-lubricated bearings are being installed in some locations on newer classes of submarines during construction and in some locations on other classes using applicable SHIPALTS (see Appendix I). These non-metallic bearings do not require periodic lubrication. Until these new non-metallic bearings are installed, bearing, bushings and washers will require periodic greasing in accordance with PMS and SMMS Performance Monitoring Program (K-Card) MRCs. The **Submarine Greasing Handbook**, NAVSEA T6350-AA-HBK-010, provides general information about greasing components, greasing requirements, and greasing methods.

561-2.8.4.1 Rod Alinement Problems. Preliminary inspection of the inboard coupling alinement following disassembly and prior to repairs has proven useful in some cases to identify unsatisfactory material conditions and target areas of focus or detailed inspection. Of particular interest in this area is potential wear of the outboard

coupling and steady rest operating rod bearings. Since wear of these components influences the inboard coupling alinement, a preliminary inspection would support identification of these or other conditions and is therefore recommended, but is not required for acceptance of the post repair condition of this equipment. If the through hull connecting rods and their associated hydraulic cylinder piston rods are not properly alined prior to coupling installation, the following problems may be experienced:

1. Scratching and galling of the rods.
2. Premature packing wear and leakage.
3. Bending of a rod.

561-2.8.4.1.1 The most common alinement problem has been the scoring and galling of the stern diving through hull connecting rod, primarily on the lower side, as it comes into contact with the guide cylinder packing gland retainer. Even though misalinement may not result in rubbing contact when the ship is surfaced, there may be a problem when the ship submerges. Pressure hull deflection resulting from submergence pressure can result in significant relative motion between the guide cylinder and the hydraulic ram. To minimize potential problems, the hydraulic cylinder piston rod must be carefully alined with the through hull connecting rod. The alinement procedure in paragraph 2561-2.8.4.2 should be used following removal and reinstallation of a hydraulic ram or through hull connecting rod. Whenever damage to a through hull connecting rod or hydraulic cylinder piston rod resulting from misalinement is suspected, the alinement verification procedure in paragraph 561-2.8.4.4 should be conducted.

561-2.8.4.2 Rod Alinement Procedure. For the rod alinement procedure, the coupling must be removed and the ship should be in a dry dock if no positive means to restrain the control surface is available.

### WARNING

**Any movement of control surfaces while coupling is removed can result in the through hull connecting rod's impacting against the hydraulic cylinder piston rod with sufficient force to cause loss of life or dismemberment. The control surfaces must be restrained to prevent movement and the general area of the connecting rods must be posted as a danger area.**

561-2.8.4.2.1 The alinement procedure is as follows:

1. Prior to removal of the coupling, record the radial clearance between the through hull connecting rod and its packing retainer and the hydraulic cylinder piston rod and its packing retainer in accordance with the procedure provided in paragraph 561-2.8.4.4.
2. Remove the coupling and position the through hull connecting rod and the hydraulic cylinder piston rod in a position corresponding to the zero degree position of the control surface. Place a straight edge parallel to the rods as shown in Figure 561-2-21. The straight edge shall be straight to +.0015 inch over its total length, with the total length of the straight edge such that the ends of the straight edge fall within one (1) inch of the hull packing gland and the hydraulic cylinder packing gland. Take measurements A and A1 within one (1) inch of the end of the straight edge and B and B1 within one (1) inch of the end of the rod thread reliefs (on the major diameter of the rod, not on the threads).

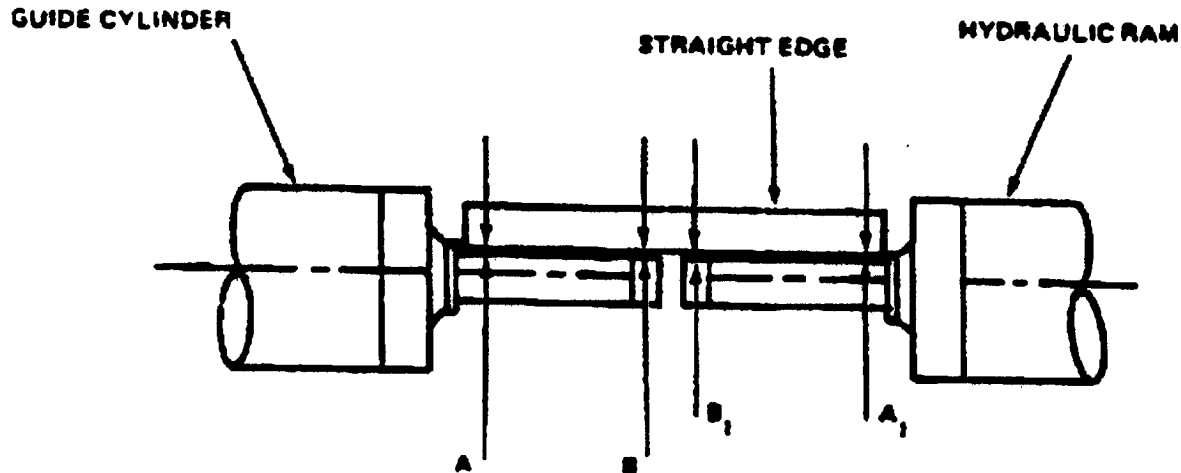

Figure 561-2-21. Rod Alinement Check With Coupling Removed

#### NOTE

It may be necessary to place plastic shims between the rods and their packing retainers in order to keep the rods centered after the coupling is removed. Exercise care when installing shims to avoid damaging the adjacent packing.

3. When alining rods of the same diameter, take measurements of A, A1, B, and B1 dimensions at the 12 and 3 o'clock positions to check alinement in the vertical and horizontal planes respectively. If all measurements are zero, alinement is perfect. If any dimension is greater than .005 inch, take corrective action.
4. When the rods are of different diameter, mount the straight edge on the larger diameter rod (i.e. points A and B on the rod of larger diameter) and take measurements between the straight edge and the smaller diameter rod (i.e. points A1 and B1 on the rod of smaller diameter). Take measurements at the 12 and 6 o'clock positions to check alinement in the vertical plane and at the 3 and 9 o'clock positions to check alinement in the horizontal plane. If all A1 and B1 measurements are equal, alinement is perfect. If the difference between A1 and B1 in a single plane is greater than .005 inch, take corrective action. (Example: If A1 at 3 o'clock is .200 inch and B1 at 3 o'clock is .206 inch, the difference of these readings taken in the horizontal plane is greater than .005 inch and corrective action is necessary.) If the difference between A1 and A1 180 degrees opposite in a single plane or B1 and B1 180 degrees opposite in a single plane is greater than .010 inch, take corrective action. (Example: If A1 at 3 o'clock is .200 inch and A1 at 9 o'clock is .211 inch, the difference of these readings taken in the horizontal plane is greater than .010 inch and corrective action is necessary.) (Alternate Method) (See [Table 561-2-10](#)) When the rods are different diameter, mount the straight edge parallel to the center line of the larger diameter rod, diameter D, (i.e. points A and B on the rod of larger diameter) and take measurements between the straight edge and the smaller diameter rod, diameter D1, (i.e. points A1 and B1 on the rod of smaller diameter). Take and record measurements at the 12 or 6 o'clock positions to check alinement in the vertical plane and at 3 or 9 o'clock positions to check alinement in the horizontal plane. If all A1 and B1 dimensions are equal, alinement is perfect. If the difference between A1 and B1 in a single plane is greater than .005 inch, take corrective action as alinement is unsatisfactory. If the difference between A and A1 (or B and B1), when adjusted for different rod dimensions, is greater than .005 inch, alinement is unsatisfactory.
5. If the thickness of the hydraulic cylinder foundation shims must be adjusted in order to aline the rods, the existing cotter pin holes in the mounting bolt/studs may no longer aline with the holes in the original nuts. In this case, the use of elastic stop nuts is preferred to drilling new holes, because the stud will be weakened by the drilling. [Table 561-2-6](#) provides standard part numbers for self-locking nuts.

**Table 561-2-10** RODS OF DIFFERENT DIAMETERS (ALTERNATE METHOD)

Measurement Positions (See Figure 561-2-18)	Actual Dimensions				Required
	A	B	A1	B1	
Vertical Plane (12 or 6 o'clock)					When rods are different diameters: (1) if the difference between A1 and B1 in a single plane is greater than 0.005 inches, alignment is unsatisfactory. (2) if the difference between (A1+R1) and (A+R) or between (B1+R1) and (B+R) in a single plane is greater than 0.005 inches, alignment is unsatisfactory.
Horizontal Plane (3 or 9 o'clock)					
Rod Diameter D =	D/2 = R =				
Rod Diameter D1 =	D/1 = R1 =				
Vertically: (A1-B1) = (A1+R1) - (A+R) = (B1+R1) - (B+R) =					
Horizontally: (A1-B1) = (A1+R1) - (A+R) = (B1+R1) - (B+R) =					
NOTE: The misalignment calculated using the above equations will result in a positive or negative number. The absolute value of this number is the magnitude of misalignment. The positive or negative sign will indicate the direction of misalignment.					

## 561-2.8.4.3 SSN 637 Class Fairwater Diving Hydraulic Cylinder Alinement Procedure

**NOTE**

For SSN 637 class fairwater planes, problems have been reported in assembling the piston rod to the through hull connecting rod. Due primarily to tight thread fit and screwing into a blind hole, air and excess lubricant have no easy way to escape; consequently, assembly can result in sufficient stress on the threads to cause galling. An acceptable solution to prevent this is to cut a 1/16" wide groove the length of the thread to the depth of the thread root diameter in the male thread. Use of this procedure in applications other than defined above requires SPECIFIC approval from NAVSEA. This alinement procedure should be accomplished with the through hull connecting rod and hydraulic cylinder piston rod in positions corresponding to the zero degree position of the control surface. The alinement procedure is as follows:

1. Completely disassemble the fairwater diving hydraulic cylinder. With all internal components removed, reinstall the body of the external cylinder in the bridge trunk.

**NOTE**

The only fairwater diving gear that should be in the trunk at this time is the body of the external cylinder and the through hull connecting rod. Perform any

required repairs of the ID of the hydraulic cylinder prior to accomplishing this procedure. The alinement check must be accomplished with the hydraulic cylinder ID rework complete.

2. Manufacture a "dummy" inner piston rod from aluminum stock as shown in [Figure 561-2-23](#). The rod will have the same dimensions as the actual inner piston rod. Thread the "dummy" piston rod into the through hull connecting rod.

#### NOTE

Fairwater plane components that are in the bridge trunk following the above should consist of the body of the outer hydraulic cylinder, the through hull connecting rod and the dummy inner piston rod. See [Figure 561-2-24](#).

3. Center the through hull connecting rod within its packing gland by rigging around the lower flanged end of the rod. The through hull connecting rod is considered centered when uniform feeler gauge measurements are obtained as discussed in paragraph [561-2.8.4.4](#). If accessible, also verify that the through hull connecting rod is centered within the bushing. Care should be taken to ensure there is no movement of the through hull connecting rod/"dummy" rod assembly after centering. Shims of uniform thickness may be inserted between the through hull connecting rod and packing gland at four locations to aid in securing the through hull connecting rod. The shim thickness should be the same as the feeler gauge measurements. Shimming between the through hull connecting rod and bushing may be done as well.
4. With the operating rods centered, measure the radial clearance between the OD of the "dummy" inner piston rod and the ID of the hydraulic cylinder. Take measurements at four locations 90 degrees apart from the upper, middle, and lower portions of the hydraulic cylinder (total of 12 measurements). Measurements should be taken in the FWD/AFT and PORT/STBD positions. Alignment is considered satisfactory when each location's measurements are within 0.002 inch of each other.

#### NOTE

While recording measurements, continually verify that the through hull connecting rod remains centered within the packing gland. If any movement has occurred, start again with step 3.

5. This procedure is to be accomplished after all other rework of the fairwater diving gear is completed and prior to final reassembly.

561-2.8.4.4 Rod Alinement Verification. Verified alinement should be as follows: After every coupling reassembly and whenever through hull rod or hydraulic piston rod wear or damage resulting from misalignment is suspected.

#### CAUTION

**Shut isolation valves and tag control valves as necessary in accordance with the TAG-OUT USERS' MANUAL (S0400-AD-URM-010/TUM) to prevent ram movement during alinement verification.**



1. With the control surface first at zero degrees and then at each mechanical hardstop position, measure and record the radial clearance between the through hull connecting rod and its packing retainer.
2. Take measurements at four locations (3, 6, 9 and 12 o'clock) around the rods.
3. Repeat steps 1 and 2 to measure the clearances for the hydraulic cylinder piston rod and its packing retainer.
4. Uniform radial clearance between the through hull connecting rod and its packing retainer, and the hydraulic piston rod and its packing retainer is evidence that the retainers are centered around the rods and that the rods are aligned. A radial clearance less than .002 inch implies possible misalignment of the rods and the need for corrective action (see [paragraph 561-2.8.4.5](#))

561-2.8.4.5 Correcting Rod Misalignment. If during the verification of the rod alignment, the rods are found to be out of alignment, this problem must be corrected prior to assembling the coupling onto the rods. The easiest way to correct this problem is to align the hydraulic cylinder piston rod to the through hull rod. First, the through hull rod must be centered in the packing gland using shims. The hydraulic cylinder must then be loosened and re-shimmed to correct the misalignment using the procedures on the applicable system and class drawings.

561-2.8.5 STEERING AND DIVING GUIDE CYLINDER ASSEMBLIES. The following discussion is general in nature and not descriptive of a particular ship class. For details applicable to a particular ship refer to selected record data such as Ship's Information Book or to assembly and detail drawings. For a typical guide cylinder assembly see [Figure 561-2-22](#).

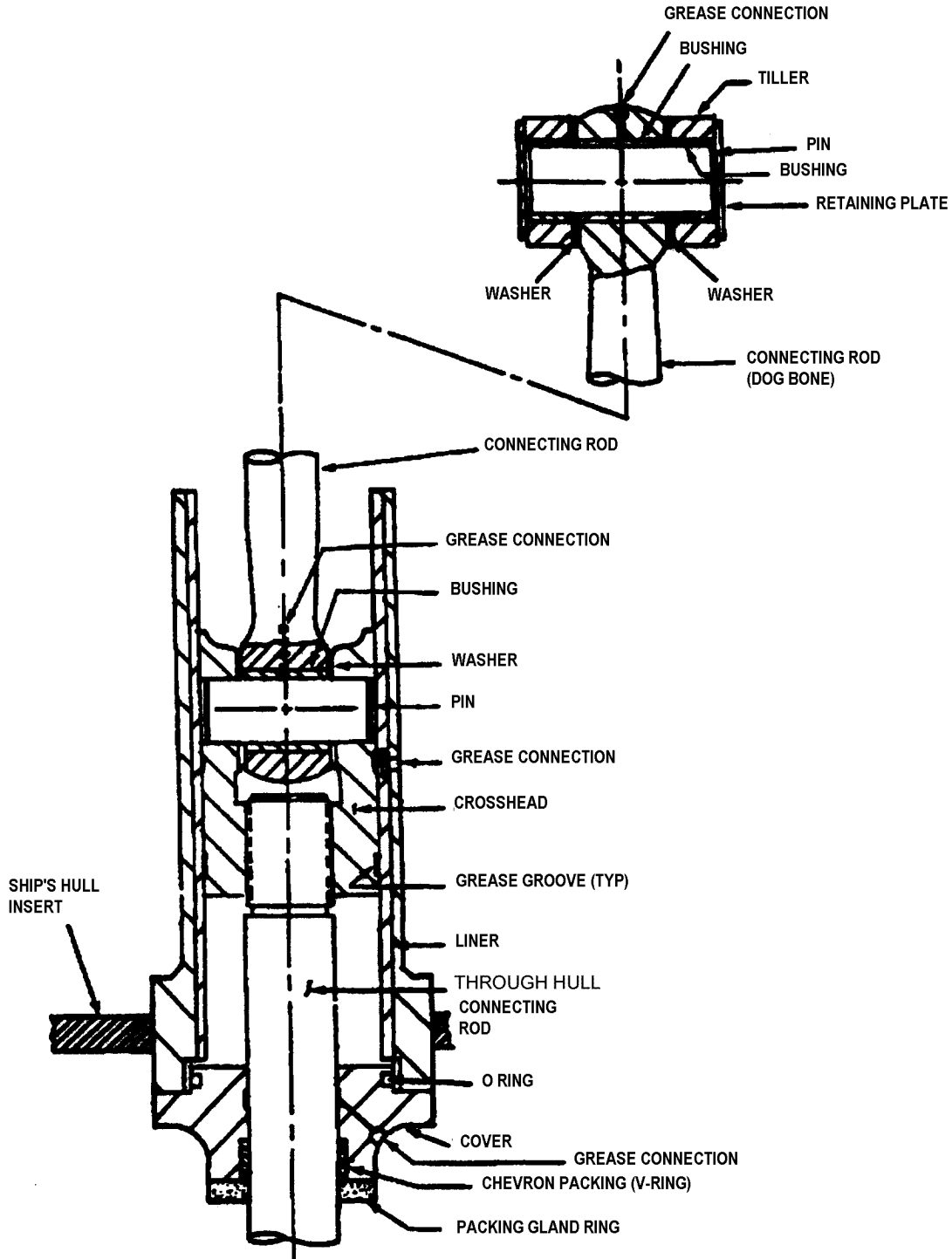

Figure 561-2-22. Guide Cylinder and Connecting Rod



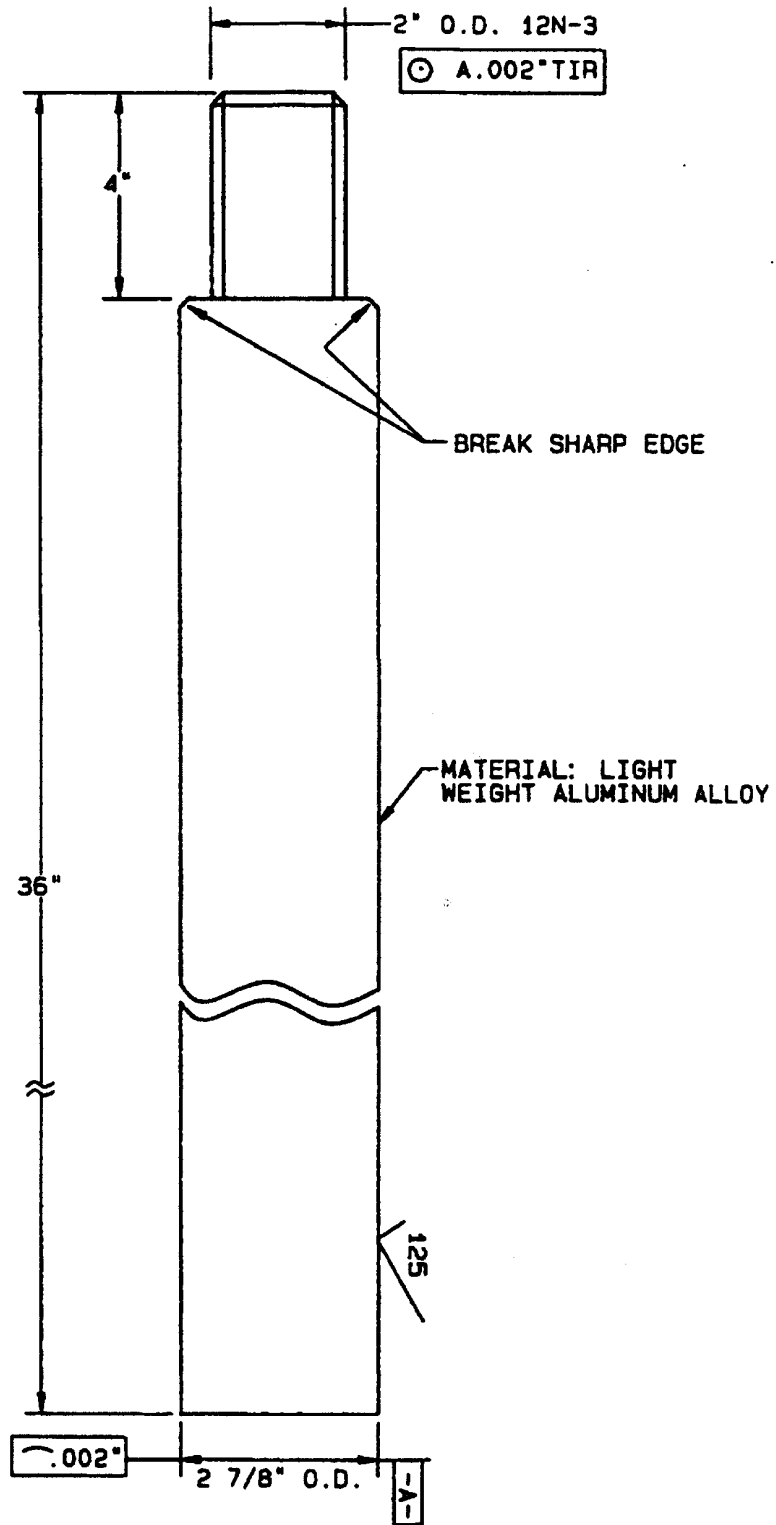

Figure 561-2-23. "Dummy" Inner Piston Rod

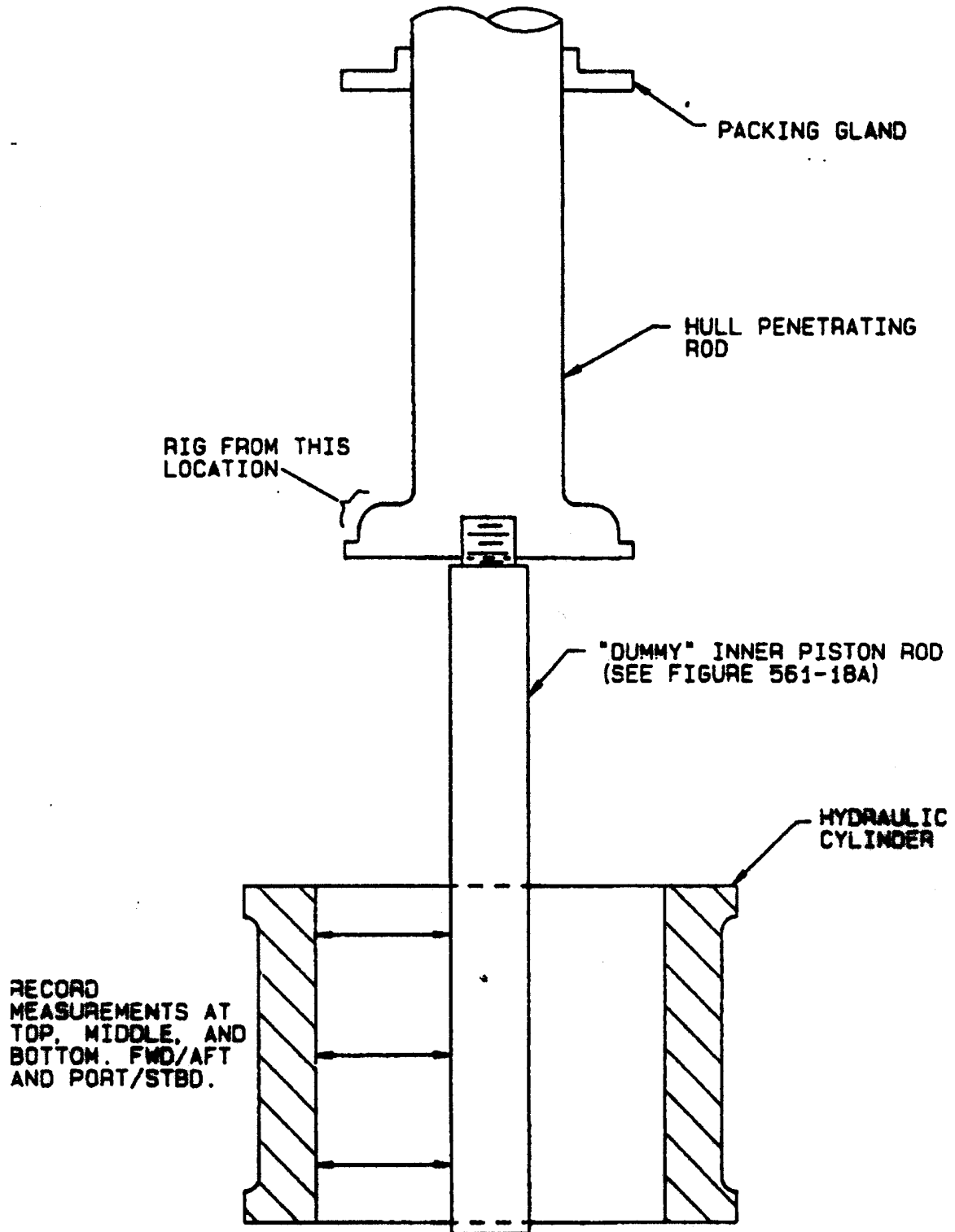

Figure 561-2-24. Fairwater Planes Ram Alinement

561-2.8.5.1 Guide Cylinder Construction. Several components are combined to form the guide cylinder assembly (see [Figure 561-2-22](#)). There are some assembly variations among classes, but the basic designs are similar. The main purpose of the guide cylinder is to provide a means for the crosshead piston to be supported while transmitting hydraulic cylinder forces. Guide cylinder assemblies are comprised of one of the following cylinders in addition to various other components discussed in paragraphs [561-2.8.5.1.1](#) through [561-2.8.5.1.3](#):

1. The steering and stern diving cylinder. Constructed of either steel or Monel, this tube is welded to the pressure hull at the tube's forward end and to the aft ballast tank bulkhead at the tubes other end. On later classes this guide cylinder passes through several ballast tanks.
2. The fairwater diving cylinder. This cylinder is usually a steel tube welded or bolted to the bridge access trunk at its bottom end, with the upper end supported by ship's structure within the fairwater itself.
3. Bow diving guide cylinder. Generally constructed of steel, this cylinder is located in the free flood area forward of the pressure hull.

561-2.8.5.1.1 Most of the steering and diving cylinders penetrating the pressure hull or bridge access trunk have a cast copper-alloy cover bolted onto the inboard end. This cover contains both a bearing surface for the connecting rod to ride on and, at its inboard end, a counterbore for packing around the connecting rod. The packing is held in place with a separate cast retainer that is in turn bolted to the cover. When installed correctly, the chevron or V packing will prevent seawater from entering the ship. For packing installation guidance refer to **NSTM Chapter 078, Volume 1, Seals**. External seal leakage criteria for hydraulic cylinders per [Table 561-2-2](#) may be used for guide cylinder cover (hull gland) V-ring or chevron seals.

561-2.8.5.1.2 Several ship classes do not have a bolted cover on the fairwater diving guide cylinder. These ships have the inboard end of the guide cylinder cast with the cylinder, forming a closed end. The only opening is where the rod penetrates. A packing counterbore and packing retainer, as noted above, are provided.

561-2.8.5.1.3 Steel guide cylinders use a gun metal or other copper-based alloy liner that provides a bearing surface for the crosshead piston to ride on. The interface between the steel guide cylinder and this liner has the potential to cause corrosion of the steel guide cylinder, i.e., galvanic corrosion in a seawater environment. To preclude this action, one of two methods is used. The most common is to apply a synthetic rubber sealant to the area of the interface. The other method is to weld the two pieces together at this joint. If the liner is cut back to remove corrosion, and, as a result, leaves insufficient bearing area for the guide piston (i.e., if any portion of the guide piston grease groove or 10% of the piston bearing area overhangs the guide cylinder liner), the bearing area must be restored. If for this or other reason the liner is removed, replace a gun metal liner with a monel (NI-CU) liner per QQ-N-281. Seal the joint between monel liner and steel cylinder by welding.

561-2.8.5.2 Guide Cylinder Liner Rubber Sealant. To prevent the entrance of seawater, a rubber sealant must be applied to the joint between the guide cylinder and the liner. This joint must be prepared for the sealant as follows:

1. Clean to bare metal (i.e., until free from all foreign substances such as scale, corrosion, and paint) both the joint to be sealed and a 1/2-inch area on each side of the joint.
2. After initial preparation is completed, wipe down the area to be sealed with an oil-free solvent such as trichloro-trifluoroethane conforming to MIL-C-81302. No surface primer is required prior to sealant application.
3. Apply sealant with an extrusion gun or spatula. If an extrusion gun is used, use a 1/8- to 3/16-inch diameter nozzle held so that it is perpendicular to the joint or seam. Exercise care with either method to prevent formation of air pockets or voids.

561-2.8.5.3 Guide Cylinder Liners Welded in Place. The guide cylinders that have the liner welded in place at the interface joint do not require the weld to be removed unless dye penetrant or magnetic particle inspection shows that a defect in the welded joint may exist. If cracks or other defects exist, the defective area is to be excavated to sound metal and repaired as necessary.

561-2.8.5.4 Guide Cylinder Covers and Packing Retainers. Covers and retainers are normally a cast copper alloy such as nickel aluminum bronze. These two pieces form a nonredundant pressure hull boundary; therefore it is imperative that they be maintained in good condition. Maintenance Requirement Card URO-MRC-015 addresses required inspections for these items (see paragraph 561-4.3.1). The packing gland retainer fits very closely with the connecting rod; misalignment of the rod may reduce this clearance to the extent that the rod will rub on the retainer and both will be damaged. If a through hull connecting rod is rubbing the packing retainer, corrective action short of realignment of the rods per paragraph 561-2.8.4.3 shall consist of either (1) increasing the diametrical clearance between rod and packing retainer to a maximum of 0.030 inch by increasing the ID of the packing gland, or (2) performing ShipAlts SSN 2830 or SSBN 1963 for applicable ships to obtain a larger diametrical clearance. Larger clearances are acceptable (if shown on applicable drawings) for installation in which V-ring adapters of duck and synthetic rubber with an approximate hardness of 70 durometer (D scale) are used to reduce extrusion. (Refer to SHIPALTS SSN 2830 and SSBN 1963). If the clearance between the guide cylinder cover and connecting rod becomes excessive, Appendix F may be used to repair the guide cylinder cover in lieu of replacement.

561-2.8.5.5 Guide Cylinder Piston. Within the guide cylinder is a closely-fitted piston. This piston, a casting made of a copper alloy such as nickel aluminum bronze, provides for the transition of liner motion from the hydraulic cylinder to the rotary motion required to operate the tiller. With the exception of the SSN 637 Class fairwater diving gear, which uses tracks instead of a piston, all other control surface gear uses a crosshead piston. The through hull connecting rod is threaded into the forward end of the piston and fixed in place with either a jamnut, pin or both. When reassembling the through hull connecting rod with the guide piston (crossheads), ensure that the threads on the rod are properly coated with sealant PR-380-M or equal. The tiller to outboard connecting rod (dogbone) is connected to the guide piston with a through pin that allows for rotation of this rod. Appropriate bushings are installed in the rod and guide piston to provide a bearing surface that is generally lubricated through an internal grease manifold. The guide piston is grease-lubricated from the same grease manifold, with the guide piston in the zero plane angle position. The guide piston is inspected periodically to determine the extent of corrosion and dealuminization. Because of the work involved, this inspection is usually done only during ship overhaul, unless abnormal operation or noise indicates the existence of a problem. A slapping noise may indicate excessive diametral clearance between the piston and guide cylinder, whereas lost motion between the hydraulic cylinder and control surfaces may indicate that either the connecting rod threaded connection is loose or the pin bushings are worn. Table 561-2-12 provides maximum operating cycle freeplay criteria for stern planes, fairwater planes, bow planes and rudder tiller and guide piston (or wrist) pin connections. Appendix G may be used as a guide for installing new bushings in the guide piston if the bushing bores are worn excessively.

561-2.8.6 TILLERS AND YOKES. Generally, the tiller used for steering and stern diving gear is cast integrally with its respective yoke. The integral tiller and yoke assembly used for steering and stern diving is mounted on the ship's axial centerline with a stock fitted between each control surface and the yoke. Taper fit and draw keys are usually used on each end of the stocks to hold them fast to corresponding tapered holes in the yokes and control surfaces. On some ships, the stocks are welded to the control surface hub, with tapers and keys used only at the yoke connection. Again, keys are installed at the interface of the stocks, yoke, and control surfaces to transmit torque (see Figure 561-2-29 and Figure 561-2-30). The tiller and yoke are preserved externally with a protective coating of paint. Internal yoke areas, where the stocks are fitted, are filled with a preservative compound such as per MIL-C-11796 Class 1A for hot application, or per MIL-C-16173 Grade 1 for cold application; however the hot application is preferred. Maintenance is limited to verifying that the protective compounds are in good condition and that pitting has not exceeded allowable limits and weakened the component. Internal yoke surfaces must be checked periodically to ensure that seawater has not leaked in, displacing the protective compound or corroding the metal of either the yoke or stocks. Fairwater planes tillers for most classes of SSNs and SSBN 726 class are forged directly onto the stock. On SSN 642, the "tiller" is a bolt-on/clamp-on assembly comprised of a forward half, or tiller, and an after half, called the tiller cap. These are bolted together on the one-piece stock and provided with keys to transmit torque to the planes (see Figure 561-2-17). Maintenance problems associated with bolt-on fairwater tiller-stock-bearing assemblies are often identified following a report of bearing noise. If stock bearing clearances and the quality of lubrication indicate that bearings are not the problem, then

tiller-thrust sleeve-stock assembly loosening is the likely cause. The factors, usually in combination, which cause tiller-thrust sleeve-stock assembly loosening are (1) loose thrust sleeve assembly fasteners, (2) loose tiller nuts, (3) excess radial clearance between tiller and stock, and (4) loose tiller keys. This may be confirmed by performing a dial indicator inspection of the stock bearing clearance and the tiller/bearing housing relative motion as follows:

- a. Measure the stock bearing clearances using dial indicators and ship's hydraulics. Ship's hydraulics are used to move the planes in and out of the rise hardstop. Mount dial indicators on port and starboard bearing housings with the indicator plungers reading the movement of the inboard ends of the outer sleeves (preload dial indicator to approx 0.050". See location of outboard indicator in [Figure 561-2-25](#). With the planes in the rise hardstop, zero the dial indicator. Slowly move the planes toward dive (usually about 3 degrees is sufficient). The dial indicator needle will move rapidly for a moment, remain steady briefly, then move erratically as the plane rotates. The clearance reading must be taken after the initial rapid movement while the needle is steady.

#### NOTE

For ships with SHIPALT SSBN 1996, stock bearing diametral clearances may be taken by mounting the dial indicator on the inboard side of the bearing housing reading directly to the stock (with the keeper ring removed). See [Figure 561-2-26](#).

- b. Measure the relative movement between the tiller and the bearing housing. Mount dial indicators on port and starboard bearing housings with indicators on port and starboard bearing housings with indicator plungers reading the movement of the outboard ends of the thrust sleeve assemblies. See location of inboard indicator in [Figure 561-2-25](#). Use ship's hydraulics to move the planes in and out of the hardstops as in step a., above.
- c. Subtract the bearing clearance readings obtained in step a. from the relative movement readings obtained in step b. If the differences on both sides are 0.010 inch or less, the tiller is considered to be satisfactorily tight for operating cycle considerations.
- d. If the difference between the inboard dial indicator and the outboard dial indicator exceeds 0.010 inch, the tiller/thrust sleeve/stock assembly is loose. Repair and troubleshoot the cause/causes as follows:
  1. Loose thrust sleeve assembly fasteners. One at a time, remove, clean, inspect, reassemble and tighten the fasteners that hold the thrust sleeve halves together and that hold the assembly to the tiller/tiller cap. Use torque values provided by NAVSEA 0990-LP-091-6010 [Appendix E](#). Repeat steps b. and v., above. If the difference on either side is still greater than 0.010 inch, looseness in the tiller is possible. Proceed to paragraph [561-2.8.6.d.\(2\)](#), below, to determine if looseness is a result of loose tiller nuts.
  2. Loose tiller nuts. With SHIPALT 2012D installed, remove clean, inspect, reassemble and tighten the nuts one at a time. DO NOT REMOVE THE BOLT. Clean and inspect the threads on both nut and bolt. Thoroughly lubricate the nut and bolt threads and the bearing face of the nut. Torque the nut to 2000 ft. lbs. Measure the relative movement between the tiller and tiller cap in both the horizontal and vertical axes by moving the planes in and out of the hardstops using ship's hydraulics as described in step a. above and by locating dial indicators, as shown in [Figure 561-2-27](#). No movement is allowed. Any movement indicates inadequate preload of the tiller fasteners and this step should be redone. If no relative movement occurs between the tiller and tiller cap, the tiller looseness is caused by excess radial clearance between tiller and stock or loose tiller keys. Contact NAVSEA for repair recommendations.
  3. Excess radial clearance between tiller and stock or loose tiller keys. Repeat steps in subparagraphs b. and c., above. If the difference on either side is still greater than 0.010 inch, there is excess radial clearance between tiller and stock or loose tiller keys. See paragraphs [561-2.8.8](#) through [561-2.8.10](#), below, to inspect and repair.

**561-2.8.7 LOOSE TILLER NUTS.** On SSN 642, two tiller bolts are fitted and two are nonfitted. All are K-monel. Due to the differences in the size and material of the nuts, as detailed on NAVSEA Dwg. 640-518-2118743, the torque required for these nuts is 2000 ft.lbs. Because of the tight clearance between the sides of the nut/bolt heads and the adjacent face of the tiller, it is impractical to fit a standard size socket on either the nut or bolt. Grinding the wall of the socket generally causes the socket to split when torque is applied. Consequently, an open-end wrench, fitted with a dynamometer and attached to a chain fall or a hydraulic jack, is sometimes used to achieve the required torque. It is an acceptable method, but is cumbersome and, when performed by

untrained personnel, inadequate and inaccurate. In order to overcome this deficiency, SHIPALT SSBN 2012D replaces the existing tiller nuts with long nuts to permit socket engagement. If not already accomplished, SHIPALT 2012D should be accomplished if tiller/tiller cap movement is found. To ensure that proper clamping force is applied, the two upper tiller nuts should be torqued while ship's hydraulics forces the tiller cap into the rise hard stop. The two lower tiller nuts should be tightened while ship's hydraulics forces the tiller cap into the dive hard stop. Blocking or a small hydraulic jack may concurrently be used between the hard stop and the tiller cap arm to keep the nuts at a workable angle. The cotter pins for the nuts, piece 18 on NAVSEA dwg 640-518-2118743, are incorrectly specified as 3 1/2 inches long. Five inch long cotter pins should be used instead. The stock number for five inch long by 3/8 inch diameter cotter pins is NSN 5315-00-187-9521.

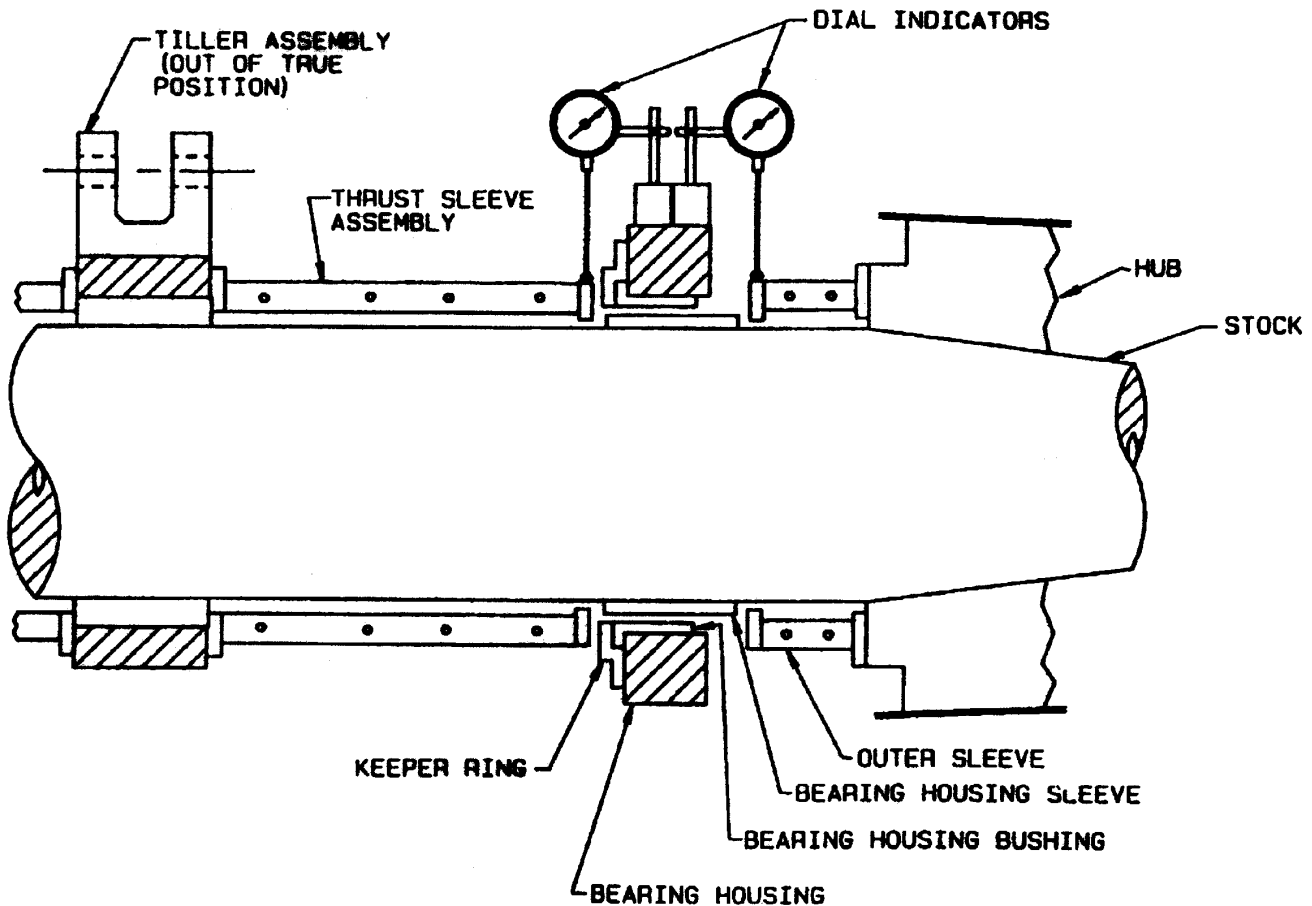

Figure 561-2-25. Stock Bearing Clearance Inspection

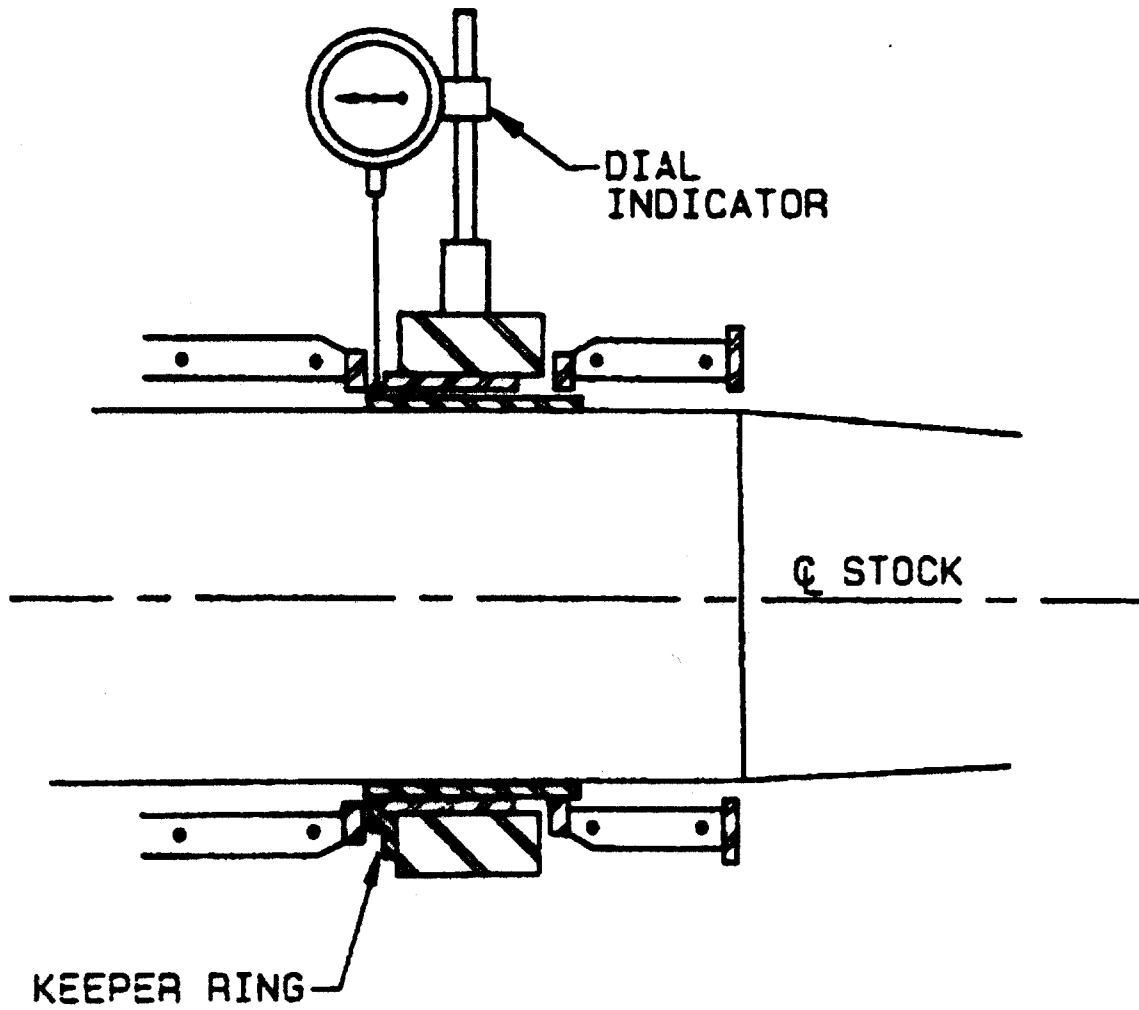

Figure 561-2-26. Stock Bearing Clearance Inspection for Ships with ShipALT SSBN 1996

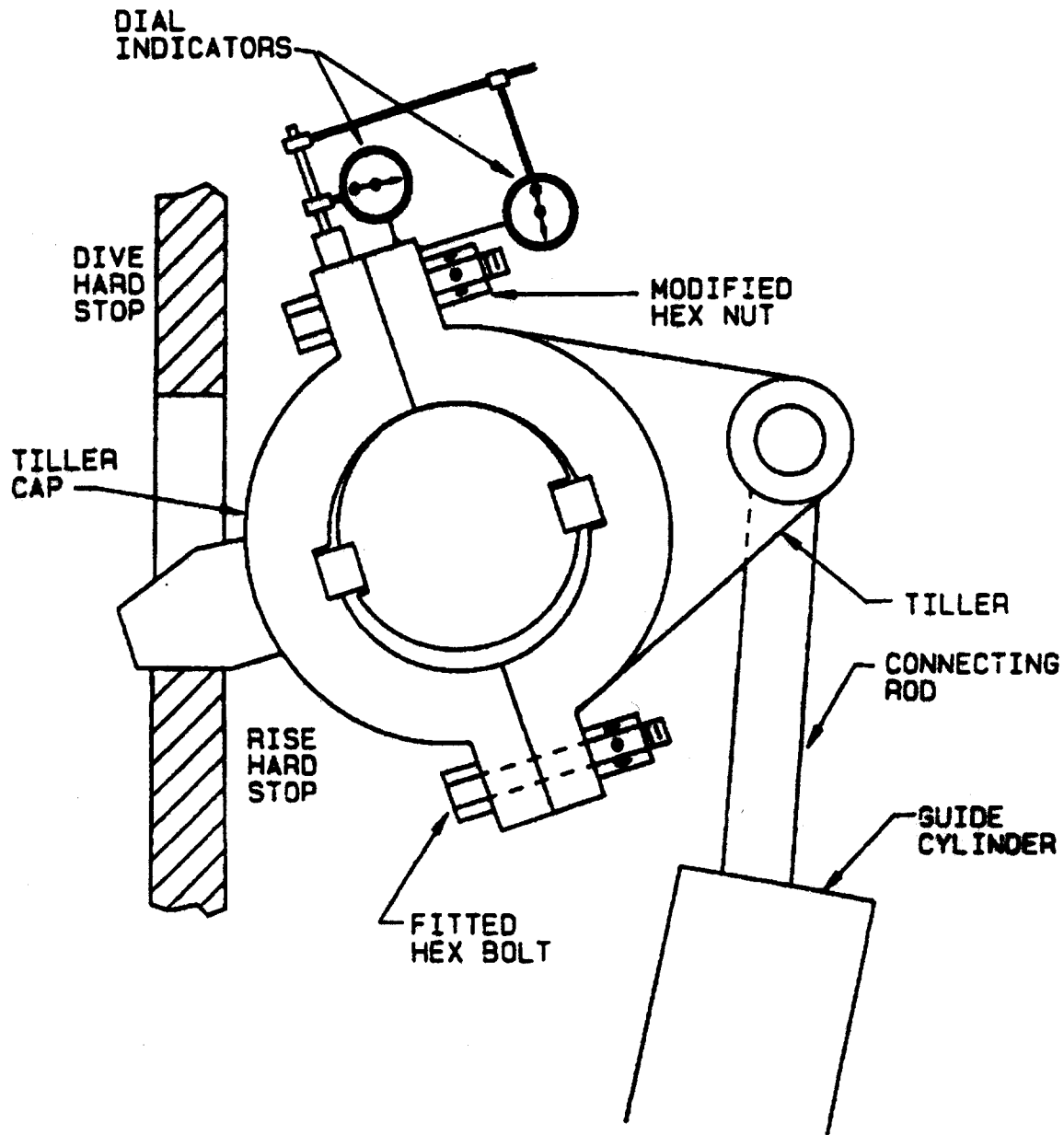

Figure 561-2-27. Fairwater Planes Tiller Inspection

**561-2.8.8 EXCESS RADIAL TILLER/STOCK CLEARANCE.** This clearance may cause wear and corrosion of the tiller/stock interface and motion-generated noise. Wear and deformation of these surfaces are greatly accelerated by any looseness, and once begun, this degradation is self-sustaining. A common, yet undesirable, repair procedure to remove excess radial clearance is to machine the inner faces of the tiller bolt face flanges. This draws the tiller/tiller cap closer together in the fore-and-aft axis, but it doesn't restore sufficient surface contact area and leaves a cavity for seawater intrusion and subsequent corrosion. This procedure may be used as a temporary repair, yet it must be followed by the preferred or permanent repair to restore design fit at the next shipyard availability. The preferred repair action is to accompany the machining of the inner flange faces with a machining of the tiller/tiller cap assembly inside diameter and keyways to restore design fit up with the stock and keys. Following any repairs there must be a check for relative movement between the assembled components in the horizontal and vertical axis.

**561-2.8.9 CORROSION OF THE TILLER/STOCK MATING SURFACES.** This is caused by seawater intrusion, and can be reduced or prevented by the following practices:



- a. Ensure that fairwater thrust sleeves are properly assembled with the flanges in the vertical axis so that rust preventive compound (RPC) fill holes will be near the top of the sleeves.
- b. Coat all mating surfaces of the tiller/tiller cap/keys/stock/thrust sleeves with anti-seize, zinc dust-petroleum thread compound, MIL-T-22361, prior to reassembly whenever the tiller is disassembled.

561-2.8.10 LOOSE TILLER KEYS. This is caused by normal working of the tiller and stock, and is accelerated by loose tiller nuts and corrosion. Design specifications permit a maximum side clearance of 0.003 inch on SSN 642. Operational ships may allow key to keyway clearance up to 25% greater than the maximum allowed by detail design drawings. Beyond this limit, keys must be replaced and/or keyways restored.

561-2.8.11 TILLER ARM BUSHINGS. SSN 642 did not have bushings installed in the tiller arms at new construction. Bushings were later installed to correct defects in the pin bores. [Appendix H](#) was used to install these bushings. Worn bushings are now being replaced with self lubricated non-metallic bearings (see [Appendix I](#)).

561-2.8.12 HARDSTOPS. Steering and diving hardstops are formed by protrusions cast onto the tillers and correspondingly built-up portions of the ship's structure. Stops are required in order to limit control-surface travel to approximately 2 degrees beyond normal operational angles whenever overhauling hydrodynamic forces from sea are experienced or in event of a hydraulic casualty. Strength and shape of stops must be maintained so that the stops will not fail with subsequent damage to the mechanical gear, hydraulic cylinder, or ship structure. To avoid damage to the hardstops a minimum amount of contact (75%) is required. [Figure 561-2-28](#) shows a representation of contact area and percentage of contact.

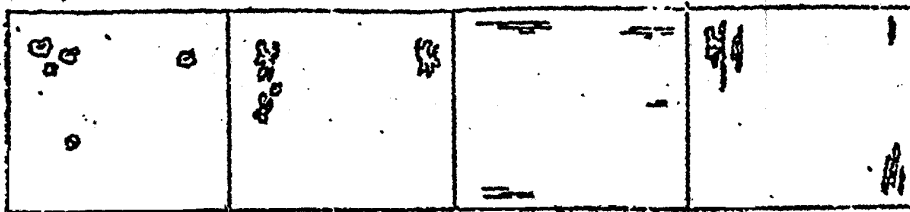

2 - 9 %

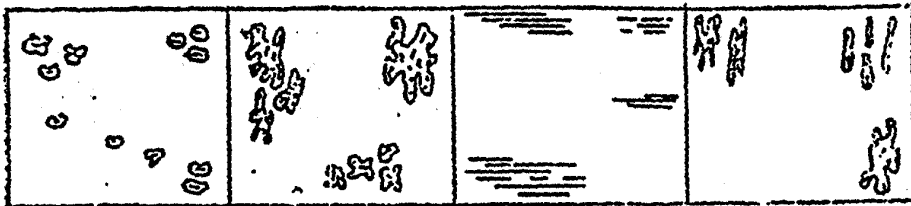

10 - 29 %

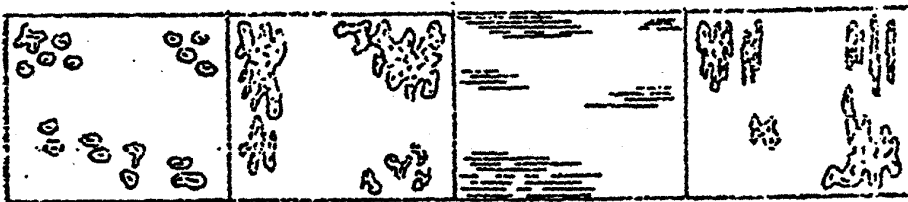

30 - 45 %



55 - 69 %



70 - 84 %

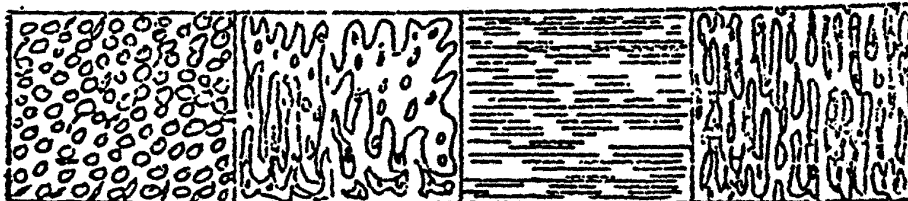

85 - 99 %

Figure 561-2-28. Hard Stop Approximate Percentage of Contact

561-2.8.13 BEARINGS. There are four basic types of bearings used in submarine steering and diving gear: journal, spherical, bushing, and thrust. In order to obtain optimum service life and operation from these bearings, a lubrication system is installed and periodic greasing in accordance with applicable PMS-MRCs is required. Many bearings and bushings are being replaced with non-metallic self-lubricated bearing material (see [Appendix I](#)).

561-2.8.13.1 Bearing Lubrication. In order to obtain optimum service life and operation from steering and diving system bearings, a lubrication system is installed. Periodic greasing in accordance with PMS and SMMS MRC's is required. The **Submarine Greasing Handbook**, NAVSEA T6350-AA-HBK-010, provides general information about greasing components, requirements, and methods.

561-2.8.13.2 Journal Bearings. Journal bearings are comprised of two concentric cylinders. One cylinder, the sleeve, is shrink-fitted onto the stock; the other cylinder, the bushing, is shrink-fitted into a housing that is either welded or bolted to the ship's structure. These pieces are most often made from centrifugally-cast cobalt-based alloy. Journal bearings are usually used for the main support (inboard) and pintle bearings on all control surfaces. (See [Figure 561-2-29](#) and [Figure 561-2-30](#).) Bearing maintenance is limited to periodic greasing, usually from an inboard grease manifold, and to periodic measurements of the diametral clearance in order to determine when replacement is necessary. The lubrication system piping and fittings should be inspected and tested periodically to ensure that the grease is flowing freely from bearing and that all components are in good condition. [Table 561-2-12](#) provides operating cycle criteria for stern planes, rudder, and fairwater stock bearing clearances.

561-2.8.13.3 Spherical Bearings. Spherical, or self-aligning bearings generally consist of: (1) a sleeve, similar to that of a journal bearing, that is interference-fitted on a stock or pin, (2) a bushing, that is interference-fitted into a housing, and (3) a spherical shaped member, or ring, that is located between the sleeve and bushing. The inside surface of the bushing is formed to fit the spherical free-moving ring. The inner cylinder surface of the ring and the outside surface of the sleeve provide the rotating bearing surface, while the spherical surfaces of the ring and bushing permit a degree of axial rotation for self-alignment (see [Figure 561-2-31](#) and [Figure 561-2-32](#)). The maintenance requirements for these bearings are the same as for the journal bearings. Inadequate lubrication of the bearing frequently causes the spherical bearing and sleeve to seize. This forces radial rotation to occur at the bushing-spherical bearing interface and causes accelerated wear of the bushing.

561-2.8.13.4 Thrust Bearings. Thrust bearings essentially are thin bearing rings used to absorb lateral thrust caused either by athwartship movement of the stern and fairwater diving planes or by the vertical load of the rudder (see [Figure 561-2-29](#) and [Figure 561-2-30](#)). These units are made from cobalt-based alloy, copper alloy, or other material. Maintenance for these bearings is the same as for journal bearings.

561-2.8.13.5 Bushings. Bushings are used at each end of the dogbone and in the tiller arms and guide cylinder piston. Bushings, usually made of bronze alloy, are pressed into their respective bores. Sleeves are not usually used (except on SSBN 726 Class where the bushing and pin sleeve are made of stellite) as the pins provide a suitable bearing surface (see [Figure 561-2-22](#)). When excessive wear or clearance indicates that bushing replacement is required, all associated components of that connection (the bore into which the bushing is pressed, the pin, the internal diameter of the other bushings through which the pin passes, and/or the tiller arm bores when no bushings are installed therein) must also be inspected and repaired or replaced as necessary. Only by inspection of all related components in the connection can you ensure that the entire cause of any excessive clearance is corrected. When it has been determined that bushing replacement is required, care must be taken to restore the design fit with the bore and the design clearance with the pin. Particularly on older ships, a bushing of design dimensions may not restore either design fit or design clearance due to wear or corrosion of other components. When replacing components, the internal diameter of the bushing and the external diameter of the pin may vary from plan dimensions by no more than 0.010 inch, provided that the clearance between mating parts conforms to plan clearance. All exceptions to this provision require NAVSEA approval. Maintenance is the same as for journal bearings.

561-2.8.13.6 Guide Piston (crosshead) Pin Plugs. Guide piston pin plugs are used on each end of guide piston pins to prevent the pins from moving laterally and scoring the guide cylinder liner. Guide piston pin plugs made of DELRIN or Ultra High Molecular Weight Poly Ethylene (UHMWPE) should be installed at the outer ends of all guide piston pins when the pistons are removed from their cylinders for any reason. The applicable dimensions for SSN 637 and SSN 642 are specified in [Table 561-2-12](#). SSN 688 class pins are fastened in place. Since the fasteners would have to fail before the pin could move laterally, plugs are unnecessary. SSBN 726 class has plugs specified in the design drawings. It may be necessary to trim plug ends to ease installation. In some instances, two plug sizes are listed for one pin; this is due to the difference in crosshead pin diameters at the ends of the pin.

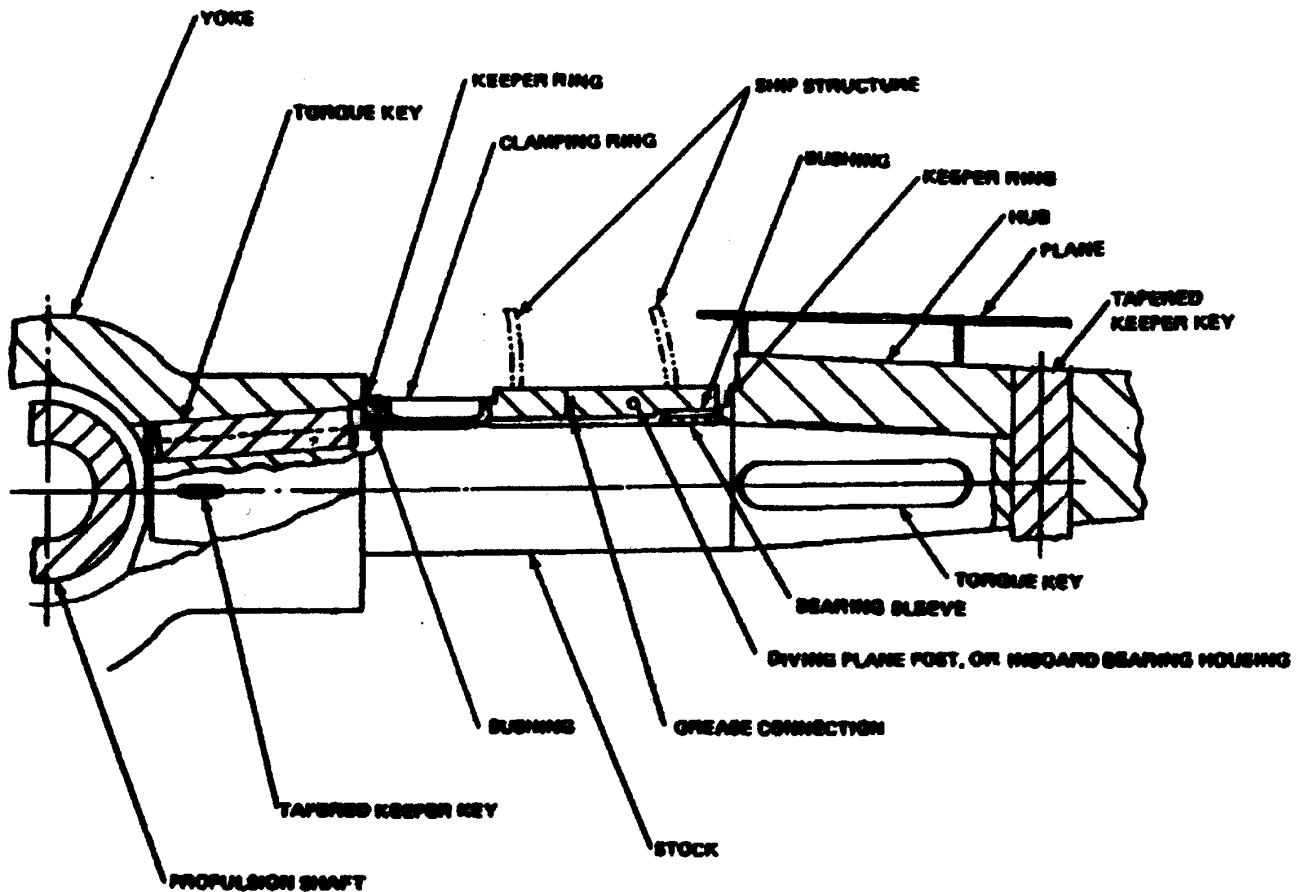

Figure 561-2-29. Stern Diving Plane

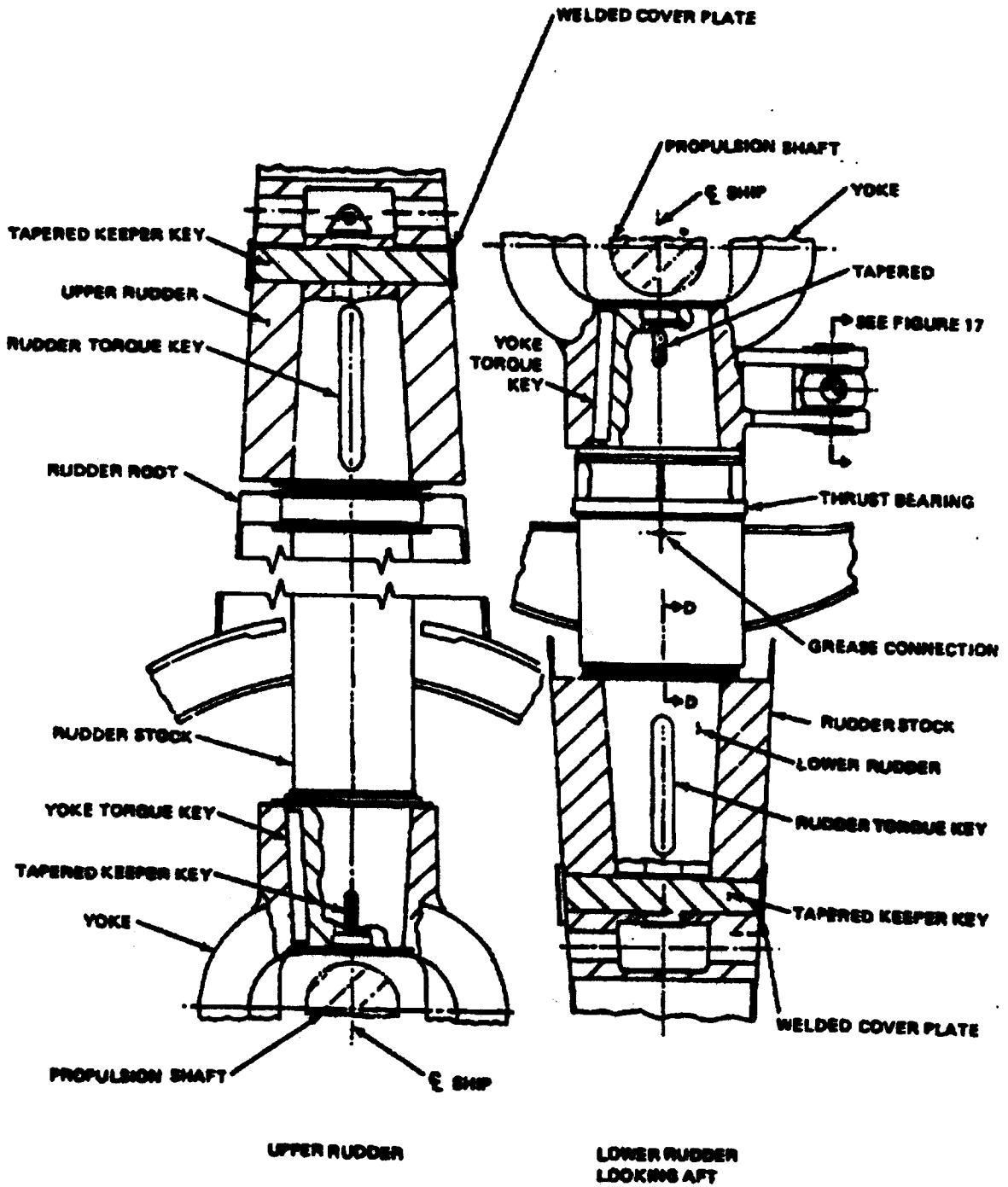

Figure 561-2-30. Rudder Assembly

**Table 561-2-11** CROSSHEAD PIN PLUG DIMENSIONS

CLASS	DIMENSION	FWTR	STERN	RUDDER
SSN 642	DIAMETER	3.75"	5.000" - 5.002"	5.000" - 5.002" 5.254" <sup>NOTE 1.</sup>
	THICKNESS	0.188"	0.431"	0.301"
SSN 637	DIAMETER	N/A	4.252" - 4.254"	4.252" - 4.254" 4.56" <sup>NOTE 1.</sup>
	THICKNESS	N/A	0.301"	0.301"

<sup>NOTE 1</sup>Two plug sizes are listed for one pin when there is a difference in crosshead pin diameters at the ends of the pin.

561-2.8.13.7 Thrust Washers. Thrust washers are usually made of bronze alloy, but are also being replaced with non-metallic self lubricating material. These washers are located between the outboard connecting rod (dogbone) and tiller arms and between the dogbone and guide piston (crosshead) to provide a bearing surface for any side loading that may develop as the control surfaces are moved. (See [Figure 561-2-22](#)). Maintenance is the same as for journal bearings, i.e., limited to greasing and periodic measurement as with journal bearings.

561-2.8.13.8 Rudder Carrier Bearings. Rudder carrier bearings transmit the vertical loads imposed by the rudder and its accessories to the hull. There are three potential rotational interfaces for the carrier bearing: between the collar and lower ring; between the lower and upper rings; and between the upper ring and the split spacer. The interface intended for rotational movement is the interface between the upper and lower rings. The lower ring is generally grooved for grease distribution on both its top and bottom surfaces. Inadequate lubrication of the carrier bearing may cause accelerated wear at any of the bearing interfaces. Sufficient wear on either or both of the lower ring's surfaces can completely eliminate the grease grooves. This will make further lubrication impossible and continue to accelerate carrier bearing wear. Rudder thrust clearance measurements and split spacer clearance measurements are intended to indicate the potential decrease in carrier bearing grease groove depth. When either of these clearances indicates that about two thirds of the depth of the grease groove has worn away (usually about 0.020 inch), the rudder should be jacked and blocked in place, the split spacer removed, and all interfaces inspected for wear. If grease grooves are worn to the above limit or other abnormal wear has occurred, repairs should be accomplished immediately.

561-2.8.13.9 Bearing Clearances. Most bearings will require replacement due to noise generation when their clearance approaches or exceeds the value listed in the REPAIR REQUIRED column of [Table 561-2-12](#). The REPAIR REQUIRED column is for use during a ship's operating cycle between scheduled repair availabilities with the intent of providing a margin of wear beyond that amount of wear allowed by Maintenance Standard (MS), Maintenance Requirement Card (MRC), etc. invoked by scheduled availabilities. As such, Repair Required criteria do not supersede appropriate criteria for scheduled repair availabilities (i.e. MS for overhauls). When the maximum allowable clearance (REPAIR REQUIRED) for a bearing is reached, repair or replacement is mandatory. Noise generation, drydock availability, operating schedule, overhaul schedule, and common sense will inevitably dictate some variation to these criteria. Criteria provided in Maintenance Standards for steering and diving components shall only be used during regular and refueling shipyard overhauls. MS criteria do not apply during ERPs, SRAs, DMPs, upkeeps and refits, or at any point during the ship's operating cycle. Feeler gauge readings are the preferred method of measuring the clearance of an assembled bearing. Steering and diving planes stock bearings generally exhibit the greatest wear at approximately 200 degrees to 210 degrees and 330 degrees to 340 degrees (with 090 degrees being forward). When possible, clearance measurements using feeler gauges should be taken every 30 degrees. As a minimum, clearance readings should be taken at each end of the 150 degrees - 330 degrees axis (and added together for the diametral clearance) and at each end of the 030 degrees - 210 degrees axis (and also added together). This will provide a view of the worst probable wear locations. On

three piece bearings (see paragraph 561-2.8.13.3, above) feeler gauge readings must be taken between the sleeve and the spherical bearing and between the spherical bearing and the bushing. All four measurements on an axis are then added to obtain the total diametral clearance. Although wear may only be taking place on one bearing surface, the total clearance is the distance through which the bearing will move to achieve impact loading. Jacking the bearing while measuring the movement with a dial indicator is an acceptable alternative when the bearing is not easily accessible. Both fore and aft and up and down (left and right for the rudder bearings) jacking measurements should be taken. When repairing or replacing bearing components, always restore design clearances. Adherence to design minimum will extend life of bearing.

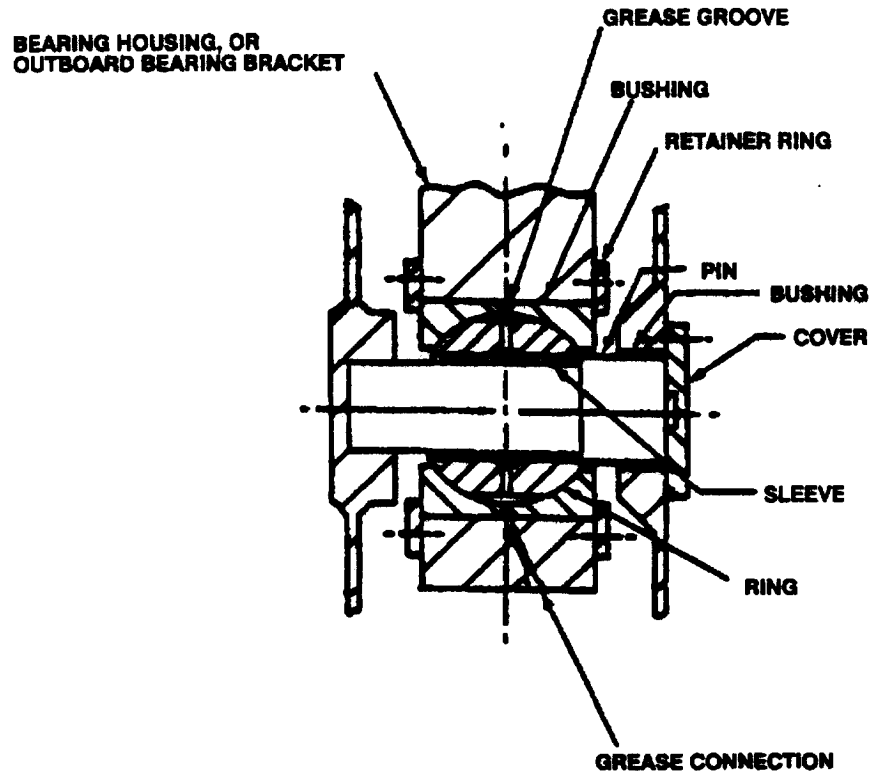

Figure 561-2-31. Typical Outboard Bearing



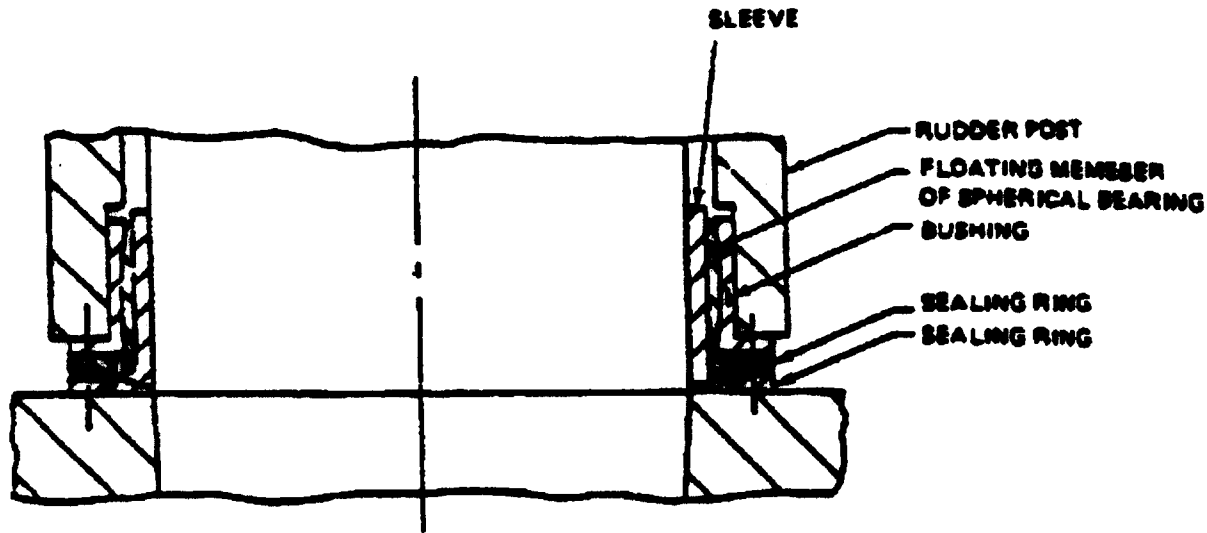

Figure 561-2-32 Typical Rudder Spherical Bearing

561-2.8.13.10 Bearing Clearance Tables. Bearing clearances for several submarine classes for use during the operating cycle are provided in [Table 561-2-12](#) for easy reference. Starred (\*) values are minimum clearances; all other values are maximum clearances.

561-2.8.13.11 Stern Planes Pintle Bearing Brackets and Assemblies. NAVSEA S6420-AB-PRO-010, **SSN/SSBN Stern Diving Plane Pintle Bearing Clearance Inspection And Stern Diving Gear Outboard Bearing Bracket Assembly Inspection**, provides detailed inspection and installation guidance for all classes of submarines.

561-2.8.13.12 Self-Lubricated Bearings Most submarine steering and diving system bearings have been manufactured from metallic materials and have required lubrication with grease. The grease is pumped from inside the pressure hull to the various bearings as required. It was found that the older greases washed away in sea water very rapidly and if the bearings weren't re-greased they would soon start making noise. The first response to this problem was to develop new greases that resisted sea water wash out. The grease currently being used CID A-A-50433 (Termalene II) is a sea water wash resistant grease. But even Termalene II still requires periodic re-greasing and the grease still pollutes the harbors when the ships are in port. The second response to this problem was to develop and test non-metallic self-lubricated bearings, which don't need grease and won't pollute. These bearings are manufactured from various materials, such as TFE and Ultra High Molecular Weight Poly-Ethylene (UHMWPE) which are "plastic" in nature and don't require grease for lubrication. (See [Appendix I](#)). Lubrication for these bearings is provided by sea water. Since all the control surfaces, except fairwater planes, are submerged in water even on the surface, lubrication is generally not a problem. If the stock bearings are not submerged and the control surfaces must be continuously cycled to support testing or maintenance, care must be exercised to avoid overheating and thus damaging the bearings. Limit control surface operational period, under these conditions, to no longer than 5 minutes with at least a 10 minute interval between operational periods. If possible, water lubrication of the bearing should be applied, as the ship design permits, using a hose or spray ring to provide water flow to the bearing. Reduce duty cycle if there is any bearing noise which is indicative of bearing overheating or binding.

561-2.8.14 FASTENERS. Fasteners for steering and diving equipment should be installed using torques derived from NAVSEA 0900-LP-091-6010, Appendix E. The exceptions to this requirement are those instances when torques are specified for various components in this chapter. When a conflict exists between design drawings and NAVSEA 0900-LP-091-6010, Appendix E, the latter shall take precedence. Subsequent to being torqued, fasteners relax and lose their preload. They must therefore be retorqued, usually two to twenty four hours after initial tightening. Due to this relaxation, LOCKTITE must not be used on bolts and studs under dynamic cyclic



loading, since, once the LOCKTITE sets, usually within an hour, the bolt or stud cannot be properly retorqued. The obvious exception to this requirement is at the blind end of a set stud, since the clamping force will be applied using the nut at the open end of the stud.

561-2.8.15 STOCKS. The stocks are forged alloy steel usually with tapers at each end to provide a close fit with both the yoke and plane hub. The tapered ends are machined to provide a metal-to-metal contact of 60 percent minimum for in-service units and 75 percent for units overhauled at a shipyard. Torque keys, usually two, are fitted along the mating surfaces of the stock taper, on the axis of the stock taper. As the name implies these keys transmit or absorb torque that is applied by the hydraulic cylinder to move the control surfaces, by hydrodynamic loading from the sea, or by shock loading. Tapered keeper keys are fitted crosswise through the stocks and into the yoke and plane hubs to pull the tapered stock ends firmly into place.

**Table 561-2-12 STEERING AND DIVING BEARING CLEARANCES**

<b>SSN 642 STERN PLANES</b>			
<b>BEARING</b>		<b>DESIGN MAX</b>	<b>REPAIR REQUIRED</b>
TILLER PIN FREEPLAY	1	0.030	0.060
WRIST PIN FREEPLAY	1	0.030	0.050
CONN ROD/TILLER THRUST	2	0.060	0.160
CONN ROD/PISTON THRUST		0.020	0.080
STOCK (INBOARD) BEARING		0.018	0.060
STOCK THRUST		0.060	0.160
GUIDE PISTON/CYLINDER LINER		0.022	0.050
<b>SSN 642 FAIRWATER PLANES</b>			
<b>BEARING</b>		<b>DESIGN MAX</b>	<b>REPAIR REQUIRED</b>
TILLER PIN FREEPLAY	1	0.016	0.050
WRIST PIN FREEPLAY	1	0.016	0.050
CONN ROD/TILLER THRUST		0.031	0.080
CONN ROD/PISTON THRUST		0.031	0.080
STOCK BEARING		0.020	0.060
STOCK THRUST		0.060	0.160
GUIDE PISTON/CYLINDER LINER		0.023	0.050
<b>SSN 642 RUDDER</b>			
<b>BEARING</b>		<b>DESIGN MAX</b>	<b>REPAIR REQUIRED</b>
TILLER PIN FREEPLAY	1	0.029	0.050
WRIST PIN FREEPLAY	1	0.030	0.050
CONN ROD/TILLER THRUST		0.020	0.080
CONN ROD/PISTON THRUST		0.020	0.080
UPPER STOCK BEARING		0.022	0.080
LOWER STOCK BEARING		0.033	0.075
STOCK THRUST		0.188	0.208
CARRIER SPLIT SPACER		0.047*	0.011*
GUIDE PISTON/CYLINDER LINER		0.022	0.050
<b>SSBN 726 CLASS STERN PLANES</b>			
<b>BEARING</b>		<b>DESIGN MAX</b>	<b>REPAIR REQUIRED</b>
TILLER PIN FREEPLAY	1	0.043	0.055
WRIST PIN FREEPLAY	1	0.045	0.055
CONN ROD/TILLER THRUST		0.100	0.160
CONN ROD/PISTON THRUST		0.090	0.160
STOCK (INBOARD) BEARING		0.010	0.065
STOCK THRUST		0.100	0.160
PINTLE (OUTBOARD) BEARING		0.021	0.060

**Table 561-2-12 STEERING AND DIVING BEARING CLEARANCES -**

Continued

GUIDE PISTON/CYLINDER LINER		0.035	0.070
<b>SSBN 726 CLASS FAIRWATER PLANES</b>			
<b>BEARING</b>		<b>DESIGN MAX</b>	<b>REPAIR REQUIRED</b>
TILLER PIN FREEPLAY	1	0.030	0.050
WRIST PIN FREEPLAY	1	0.025	0.060
CONN ROD/TILLER THRUST		0.200	0.230
CONN ROD/PISTON THRUST		0.065	0.100
STOCK BEARING		0.055	0.080
STOCK THRUST		0.150	0.200
GUIDE PISTON/CYLINDER LINER		0.030	0.065
<b>SSBN 726 CLASS RUDDER</b>			
<b>BEARING</b>		<b>DESIGN MAX</b>	<b>REPAIR REQUIRED</b>
TILLER PIN FREEPLAY	1	0.053	0.065
WRIST PIN FREEPLAY	1	0.043	0.055
CONN ROD/TILLER THRUST		0.090	0.120
CONN ROD/PISTON THRUST		0.090	0.120
UPPER STOCK BEARING		0.020	0.080
LOWER STOCK BEARING		0.020	0.080
STOCK THRUST		0.055	0.105
CARRIER SPLIT SPACER	3	N/A	N/A
GUIDE PISTON/CYLINDER LINER		0.035	0.070
<b>SSN 637 CLASS STERN PLANES</b>			
<b>BEARING</b>		<b>DESIGN MAX</b>	<b>REPAIR REQUIRED</b>
TILLER PIN FREEPLAY	1	0.033	0.045
WRIST PIN FREEPLAY	1	0.033	0.045
CONN ROD/TILLER THRUST	2	0.060	0.120
CONN ROD/PISTON THRUST		0.020	0.090
STOCK (INBOARD) BEARING		0.018	0.060
STOCK THRUST		0.060	0.120
PINTLE (OUTBOARD) BEARING		0.021	0.050
GUIDE PISTON/CYLINDER LINER		0.022	0.050
<b>SSN 637 CLASS FAIRWATER PLANES</b>			
<b>BEARING</b>		<b>DESIGN MAX</b>	<b>REPAIR REQUIRED</b>
TILLER PIN FREEPLAY	1	0.014	0.050
WRIST PIN FREEPLAY	1	0.014	0.050
CONN ROD/TILLER THRUST	2	0.030	0.100
CONN ROD/PISTON THRUST		0.030	0.080
STOCK BEARING		0.018	0.065
STOCK THRUST		0.060	0.120
GUIDE SLIDE/CROSSHEAD		0.026	0.050
<b>SSN 637 CLASS RUDDER</b>			
<b>BEARING</b>		<b>DESIGN MAX</b>	<b>REPAIR REQUIRED</b>
TILLER PIN FREEPLAY	1	0.033	0.045
WRIST PIN FREEPLAY	1	0.022	0.045
CONN ROD/TILLER THRUST		0.020	0.080
CONN ROD/PISTON THRUST		0.020	0.080
UPPER STOCK BEARING		0.032	0.075

**Table 561-2-12 STEERING AND DIVING BEARING CLEARANCES -**

Continued

LOWER STOCK BEARING		0.032	0.075
STOCK THRUST		0.188	0.208
CARRIER SPLIT SPACER		0.047*	0.011*
GUIDE PISTON/CYLINDER LINER		0.022	0.050
<b>SSN 688 CLASS STERN PLANES</b>			
<b>BEARING</b>		<b>DESIGN MAX</b>	<b>REPAIR REQUIRED</b>
TILLER PIN FREEPLAY	1	0.012	0.040
WRIST PIN FREEPLAY	1	0.012	0.040
CONN ROD/TILLER THRUST		0.070	0.160
CONN ROD/PISTON THRUST		0.102	0.140
STOCK (INBOARD) BEARING		0.018	0.065
STOCK THRUST		0.060	0.160
PINTLE (OUTBOARD) BEARING		0.014	0.050
GUIDE PISTON/CYLINDER LINER		0.026	0.050
<b>SSN 688 FAIRWATER PLANES</b>			
<b>BEARING</b>		<b>DESIGN MAX</b>	<b>REPAIR REQUIRED</b>
TILLER PIN FREEPLAY	1	0.019	0.050
WRIST PIN FREEPLAY	1	0.017	0.050
CONN ROD/TILLER THRUST		0.103	0.140
CONN ROD/PISTON THRUST		0.103	0.140
STOCK (BEARING)		0.032	0.070
STOCK THRUST W/O S/A 3604	4	0.060	0.120
STOCK THRUST WITH S/A 3604	4	0.100	0.150
GUIDE PISTON/CYLINDER LINER		0.025	0.050
<b>SSN 688 CLASS RUDDER</b>			
<b>BEARING</b>		<b>DESIGN MAX</b>	<b>REPAIR REQUIRED</b>
TILLER PIN FREEPLAY	1	0.018	0.040
WRIST PIN FREEPLAY	1	0.018	0.040
CONN ROD/TILLER THRUST		0.140	0.180
CONN ROD/PISTON THRUST		0.102	0.140
UPPER STOCK BEARING		0.034	0.075
LOWER STOCK BEARING		0.034	0.075
STOCK THRUST		0.188	0.2275*
CARRIER SPLIT SPACER		0.188*	0.146*
GUIDE PISTON/CYLINDER LINER		0.023	0.050
<b>SSN 688 CLASS BOW PLANES</b>			
<b>BEARING</b>		<b>DESIGN MAX</b>	<b>REPAIR REQUIRED</b>
TILLER PIN FREEPLAY		0.015	0.020
CROSSHEAD FREEPLAY		0.014	0.019
CONN ROD/TILLER THRUST		0.060	0.065
CONN ROD/PISTON THRUST		0.1094	0.1875
PEDESTAL BRG (STBD) FREEPLAY		0.04 (0.036)	0.053 (0.049)
PEDESTAL BRG (PORT) FREEPLAY		0.04 (0.036)	0.053 (0.049)
CENTERLINE BEARING FREEPLAY		0.018	0.024
STOCK BEARING		0.031	0.037
GUIDE PISTON/CROSSHEAD GUIDE		0.015	0.018
<b>SSN 21 CLASS STERN PLANES (INNER)</b>			

**Table 561-2-12 STEERING AND DIVING BEARING CLEARANCES -**

Continued

<b>BEARING</b>		<b>DESIGN MAX</b>		<b>REPAIR REQUIRED</b>	
TILLER PIN FREEPLAY		0.022		0.027	
CROSSHEAD FREEPLAY		0.022		0.027	
CONN ROD/TILLER THRUST		0.099		0.126	
CONN ROD/PISTON THRUST		0.094		0.116	
STOCK (INBOARD) BRG (FLAP)		0.028		0.060	
STOCK THRUST		0.120		0.140	
PINTLE (OUTBD) BRG (FLAP)		0.023		0.060	
GUIDE PISTON/CYLINDER LINER		<b>Max</b>	<b>42mos.</b>	<b>84mos.</b>	<b>120mos.</b>
(minimum) stave material remaining		0.218	0.135	0.072	0.203 (min) new
<b>SSN 21 CLASS STERN PLANES (OUTER)</b>					
<b>BEARING</b>		<b>DESIGN MAX</b>		<b>REPAIR REQUIRED</b>	
TILLER PIN FREEPLAY		0.022		0.027	
CROSSHEAD FREEPLAY		0.022		0.027	
CONN ROD/TILLER THRUST		0.099		0.126	
CONN ROD/PISTON THRUST		0.094		0.116	
STOCK (INBOARD) BRG (TIP)		0.027		0.060	
STOCK THRUST		0.120		0.140	
PINTLE (OUTBD) BRG (TIP)		0.029		0.060	
GUIDE PISTON/CYLINDER LINER		<b>Max</b>	<b>42mos.</b>	<b>84mos.</b>	<b>120mos.</b>
(minimum) stave material remaining		0.1145	0.061	0.038	0.092 (min) new
<b>SSN 21 CLASS RUDDER</b>					
<b>BEARING</b>		<b>DESIGN MAX</b>		<b>REPAIR REQUIRED</b>	
TILLER PIN FREEPLAY		0.0255		0.032	
CROSSHEAD FREEPLAY		0.0255		0.032	
CONN ROD/TILLER THRUST		0.145		0.168	
CONN ROD/PISTON THRUST		0.145		0.168	
UPPER STOCK BEARING		0.039		0.060	
LOWER STOCK BEARING		0.039		0.060	
STOCK THRUST		0.090		0.120	
GUIDE PISTON/CYLINDER LINER		<b>Max</b>	<b>42mos.</b>	<b>84mos.</b>	<b>120mos.</b>
(minimum) stave material remaining		0.2425	0.151	0.081	0.227 (min) new
<b>SSN 21 CLASS BOW PLANES</b>					
<b>BEARING</b>		<b>DESIGN MAX</b>		<b>REPAIR REQUIRED</b>	
TILLER PIN FREEPLAY		0.023		0.035	
CROSSHEAD FREEPLAY		0.023		0.035	
CONN ROD/TILLER THRUST		0.190		0.230	
CONN ROD/PISTON THRUST		0.190		0.230	
STOCK (INBOARD) BEARING		0.044		0.062	
STOCK THRUST		0.044		0.062	
CENTERLINE BEARING THRUST		0.025		0.033	
GUIDE PISTON/CYLINDER LINER		<b>Max</b>	<b>42mos.</b>	<b>84mos.</b>	<b>120mos.</b>
(minimum) stave material remaining		0.1145	0.061	0.038	0.092 (min) new

**Table 561-2-12 STEERING AND DIVING BEARING CLEARANCES -**

Continued

Starred (\*) values are minimum clearances; all other values are maximum clearances.

<sup>1</sup>This value has a double meaning. When an assembled freeplay (double clearance) is measured, the value is the maximum allowable freeplay for the connection. When the connection is disassembled and the bearing components are measured by micrometer, this value is both the maximum allowable freeplay for the connection and the maximum allowable individual clearance between the wrist or tiller pin and any mating bore.

<sup>2</sup>In order to prevent excessive wear or bending of the connecting rod caused by athwartship movement of the yoke, this clearance must be restored to the value indicated instead of the per plan design clearance.

<sup>3</sup>Clearance is established at final assembly between split spacer and lower rudder post, and stamped on aft side of lower rudder post. Allowed reduction from this initial measurement is 0.020.

<sup>4</sup>Readings taken forward and aft between keeper ring and bushing flange.

## **561-2.9 MOLECULAR METAL COATING FOR RESURFACING OF COMPONENTS**

561-2.9.1 APPLICABLE COMPONENTS. The use of Belzona Molecular Super Metal Coating (Belzona Molecular Inc., Garden City, NY) is authorized for repair of corroded or damaged components in static and non-load bearing areas of the following steering gear, stern diving gear, and fairwater diving gear components:

- a. Fairwater diving gear hydraulic ram head static O-ring or quad-ring grooves.
- b. Cross head-to-tiller connecting rod including rod end thrust faces where damage does not exceed 1/4 inch depth on nonbearing surfaces or 3/64 inch on thrust faces.
- c. Guide cylinder outside diameter where damage does not exceed 1/8 inch depth.
- d. Guide cylinder hull fitting external and internal surfaces, excluding sealing surface for guide cylinder cover o-rings or sealing sleeve o-rings, where damage does not exceed 1/8 inch depth.
- e. Yoke internal and external surfaces where damage does not exceed 1/4 inch depth. Coating shall not be used in key slots, in areas where covers or pads are to be welded, on tiller arms to depths greater than 3/64 inch, or in taper bores where coating constitutes greater than 1 percent continuous coverage.
- f. Control surface stocks where damage does not exceed 3/16 inch depth. Do not use coating on stock tapers where coating constitutes greater than 1 percent continuous coverage, or in key slots.
- g. Control surface hub internal and external surfaces where damage does not exceed 1/4 inch depth. Do not use coating in areas where covers or pads are to be welded, in taper bores where coating constitutes greater than 1 percent continuous coverage, in key slots except for fairwater diving gear axial keys.
- h. Control surface stock seal rings, thrust rings, and split spacers.

561-2.9.1.1 Application. Depths stated in paragraph 561-2.9.1 include clean-up and excavation required in preparation of surface for coating application. Coating shall be considered to have no strength value with respect to the structural integrity of the components on which it is applied. Before surface preparation required by the coating manufacturer, bake all components previously subjected to oil or grease at 375°F for a minimum of eight hours to remove petroleum residue.

561-2.9.1.2 Restrictions and Reporting. Although use of Molecular Metal repair is encouraged for those applications stated in paragraph 561-2.9, specific NAVSEA approval is required before use in all other areas. Document and report use to NAVSEA so that inspection of repairs may be made during subsequent availabilities to determine in-service durability and acceptability. Report documents shall include ship number, date of application, drawing number and part number of component on which repair was used, and a description of the area and extent of repair.

561-2.9.1.3 Control Surfaces. Control surfaces are usually fabricated of hull-type steel plating placed over a structural framework. Control surfaces, which are watertight, are internally supported against sea pressure by either plastic (syntactic-foam) filler or end-grained wood and vegetable pitch. Control surfaces should be checked periodically for leakage. If the control surface is to be removed, leakage can then be detected by weighing the control surface and comparing the current weight to the as-manufactured weight. If leakage is to be checked with the plane in place a small inspection hole may have to be cut in the plane. Filler material should be inspected and maintained in accordance with the appropriate MSs.

561-2.9.1.3.1 Because parts of the steering and diving gear are located in freeflood areas, they are almost continually submerged in seawater even when the submarine is on the surface (only the fairwater diving gear is not submerged when the submarine is surfaced).

561-2.9.1.3.2 The stabilizer and stern plane surface plates should be visually inspected for dents, cracks, and pits. Dents up to 3/4 inches below the molded line are permitted aft of the 10 percent chord line, measured from the leading edge. Dents forward of the 10 percent chord line should not exceed 1/2 inch in depth below the molded line. Not more than 2 percent of the total surface area forward of the 10 percent chord line and not more than 10 percent of the total surface area aft of the 10 percent chord line is allowed to be dented, subject to the above criteria. Pitting of the control surface should be inspected and repaired in accordance with **NSTM Chapter 074 Volume 1, Welding and Allied Processes**, and the appropriate Technical Repair Standards. Rudders and planes should be operated to check performance, ease of movement, and the absence of any unusual noise. This check should be conducted at dockside.

### SECTION 3.

#### OPERATING LIMITATIONS

##### 561-3.1 CONTROL SURFACE RATES

561-3.1.1 For most classes of submarines, the original shipbuilding specifications identify the range of acceptable control surface rates. For most later classes of submarines, the rate ranges are from 5 to 9 degrees per second for the diving planes and from 3 to 5 degrees per second for the rudder. In many cases, the hydraulic power plant supplying power to the control surfaces is not designed to provide simultaneous operation of the control surfaces at the maximum rate. Therefore, if the control surface rates are set at the maximum allowable limit, the chances of saturating the power plant increase; that is, it becomes more probable that emptying the accumulators will result in temporary reduction or loss of hydraulic system pressure.

##### 561-3.2 CONTROL SURFACE RATE SELECTION

561-3.2.1 On some classes of submarines, the design rates selected by the design activity are identified on steering and diving system drawings. When the rates are not specifically identified on system diagrams, the following documentation should be used for guidance in selecting the rate to support the Unrestricted-Operations (URO) program:

- a. URO-MRC 016 or 019(paragraph 561-4.3) for bow diving and stern diving systems. For some classes URO-MRC 016 and 019 were combined into 016 and URO-MRC 019 was cancelled.
- b. Original shipbuilding specifications. The control surface rate should be set at the midpoint of the allowable range during dockside system grooming. A slightly reduced rate will exist during at-sea operation as a result of additional hydrodynamic loading of the control surfaces. Therefore, the rate should be checked during normal at-sea operation and verified to be above the minimum allowable. On a few systems it may not be possible to obtain the specified rates at maximum ship speed, because of marginal designs.

### **561-3.3 ASTERN SPEED LIMITATIONS FOR SURFACE OPERATION OF THE RUDDER**

561-3.3.1 Submarine steering systems are sized for ahead operation, and their limitations on surfaced operation astern are deliberately accepted. Full astern propeller speed is allowed for stopping or slowing the ship. However, once the ship starts moving astern, the steering gear provides rudder control only for low astern speeds. Control at higher speeds would usually require a much larger hydraulic cylinder and often an increased output capacity of the hydraulic power plant. The allowable sustained surface speed astern is accordingly defined as the number of propeller revolutions per minute (r/min) that can be allowed continuously if the rudder orders are still to be followed. This number of r/min is determined from actual sea trials with hydraulic cylinder pressures observed while astern propeller speed is systematically increased. Once defined, the maximum allowable sustained surface speed astern is permanently identified on a warning plate installed aboard ship. This sustained speed must not be exceeded for the following reasons:

- a. Adequate ship control cannot be maintained with smaller rudder angles.
- b. Larger rudder angles will result in overpressurization of the operating cylinder and piping, with possible damage to the system. On ships with relief valves installed, the relief valves will lift and the rudder will be driven into the hardstops. Because it will be impossible to move the rudder off the hardstop position until astern speed is reduced, loss of control will occur.



## SECTION 4.

### OVERALL MATERIAL AND MAINTENANCE REQUIREMENTS

#### 561-4.1 STEERING AND DIVING HYDRAULIC SYSTEM MATERIAL IDENTIFICATION AND CONTROL (LEVEL I)

561-4.1.1 Portions of the steering and diving hydraulic systems require Level I material identification in accordance with NAVSEA 0948-LP-045-7010, **Material Control Standard**. In general, hydraulic systems, including components such as valves and piping, for any steering or diving control surface, failure of which would cause loss of both the normal and emergency modes of control surface operation, are designated Level I. Refer to applicable ships drawings for identification of Level I components and required material.

#### 561-4.2 STEERING AND DIVING MATERIAL CERTIFICATION REQUIREMENTS FOR THE SUBMARINE SAFETY PROGRAM

561-4.2.1 NAVSEA 0924-LP-062-0010, **Submarine Safety (SUBSAFE) Requirements Manual, for the Submarine Safety Program** specifies the minimum actions required to provide a satisfactory level of confidence in both the integrity of submarine systems and the adequacy of certain damage control capabilities. The following elements of the diving system are considered to be within the submarine material certification boundary:

- a. Rudder, Fairwater Planes and Bow diving linkage through hull connecting rod and guide cylinder cover or hull penetration.
- b. Hydraulic piping and components that are necessary for both the normal and emergency operational modes of the stern diving system, including any normally shut isolation valves that form a boundary for that portion of the system that is common to both normal and emergency modes.
- c. The diving control sticks and their associated linkages up to but not including any hydraulic control valve operated by the linkage.
- d. The stern diving operating linkage from the hydraulic cylinder (ram) up to and including the stern planes yoke.
- e. All stern diving control and feedback linkages and all linkages associated with normal, auxiliary, or mechanical indication of the stern planes angles.

#### NOTE

If a component is questionable whether it is SUBSAFE or not should be referred to NAVSEA 0924-LP-062-0010.

561-4.2.2 Material certification is jeopardized every time work is done, for any reason, within the established submarine material certification boundary. This includes work done: during the operating period; during an overhaul or availability period; for incorporation of alterations, modifications, or changes; for corrective maintenance; or as part of the preventive maintenance program.

561-4.2.3 To ensure that steering and diving system material conditions remain satisfactory to support continued certification, the requirements of NAVSEA 0924-LP-062-0010 shall be complied with whenever work involving SUBSAFE elements of the diving system is performed.



### 561-4.3 STEERING AND DIVING SYSTEM URO-MRCs

561-4.3.1 NAVSEA 0924-LP-062-0010 specifies the maintenance requirements and identifies the responsibilities and actions necessary to support continued unrestricted submarine operations to design test depth.

1. The maintenance requirements under this
2. Unrestricted-Operations (URO) program are issued in Maintenance Requirement Cards (MRCs) format. The intent of the URO-MRCs is to ensure early identification of any degradation of the material condition within the hull integrity boundary and those systems affecting ship recoverability.
3. The URO-MRCs concerning steering and diving are as follows:
  - a. MRC-015-Inspect Stern Diving Gear.
  - b. MRC-016-Inspect Internal Control Linkage / or Inspect Internal Control Linkage and Conduct Operational Test of the Stern Diving System.
  - c. MRC-019-Conduct Operational Test of the Stern Diving System.

#### NOTE

Some submarine classes perform both URO-MRC-016 and 019, while other classes perform a combined inspection and operational test in URO-MRC-016.

- d. MRC-020-Inspect Internal Surfaces of 2014/2017 Series Aluminum Alloy Component Bodies Installed in the Bow and Stern Diving Hydraulic System.
- e. MRC-021-Inspect Surfaces of 2024 Series Aluminum Alloy Component Bodies Installed in the Bow and Stern Diving Hydraulic System.



## APPENDIX A.

### STEERING AND DIVING HYDRAULIC CYLINDER INTERNAL REPAIR

#### 561-A.1 METHOD 1

561-A.1.1 Defects in bores of hydraulic cylinders, which are chrome plated, may be repaired by honing out (overboring) the defects and restoring the inside diameters of the hydraulic cylinder to drawing dimensions by either CRES sleeving or chrome plating. As required by Section 9210-1-c of the **General Overhaul Specification for Deep Diving SSBN/SSN Submarines** (NAVSEA 0902-LP-018-2010), chrome plating is used to restore defects up to 0.010 in. deep and CRES sleeving, an expensive and difficult process, is used to restore defects deeper than 0.010 inch. See [Table 561-A-1](#) and [Figure 561-A-1](#) for sleeving details.

#### 561-A.2 METHOD 2

561-A.2.1 Defects in bores of hydraulic cylinders may be repaired by overboring the hydraulic cylinder inside diameter a maximum of 0.040 in. beyond the drawing diameter (on SSN688 and SSBN726 classes overboring is only allowed on the inside diameter in way of the piston travel). See Appendix B, hydraulic cylinder head repair for oversized cylinders, to maintain drawing clearances and seal compression. The increase in piston and head diameters (for SSN688 and SSBN726 classes only the piston requires a corresponding increase to maintain drawing clearance), must not be accomplished by chrome plating.

561-A.2.2 In addition, the final inside diameter and plating thickness of overbored cylinders must be documented for the next overhauling activity on the ship's Selected Record Drawing (SRD) titled, "Steering and Diving Hydraulic System Tables". A label plate shall be affixed to the overbored cylinder indicating the dimensions of the final inside diameter and plating thickness.

#### NOTE

Method 2 is more economical than Method 1 and is the preferred repair.

**Table 561-A-1** DIMENSIONS FOR STEERING AND DIVING  
HYDRAULIC CYLINDER INTERNAL SLEEVING CLASS CYLINDER  
DIMENSION A REFERENCE

CLASS	CYLINDER	DIMENSION A	REFERENCE
637	FWTR	12" + 1/64"	518-2143705
637	STERN	9-1/2" + 1/64"	518-2143678
637	RUDDER	11" + 1/64"	518-2143669
640	FWTR	11-1/2" + 1/64"	518-2118745 518-2150531
640	STERN	11-1/2" + 1/64"	518-2118725 518-2149812
640	RUDDER	13-1/2" + 1/64"	518-2118717 518-2149813

Sleeve, PC 1, as identified in [Figure 561-A-1](#), to CRES H.R. ANL QQ-S-766 CL 316L 5/8" plate. Use referenced drawings for dimensions and details not specifically mentioned in [Figure 561-A-1](#).

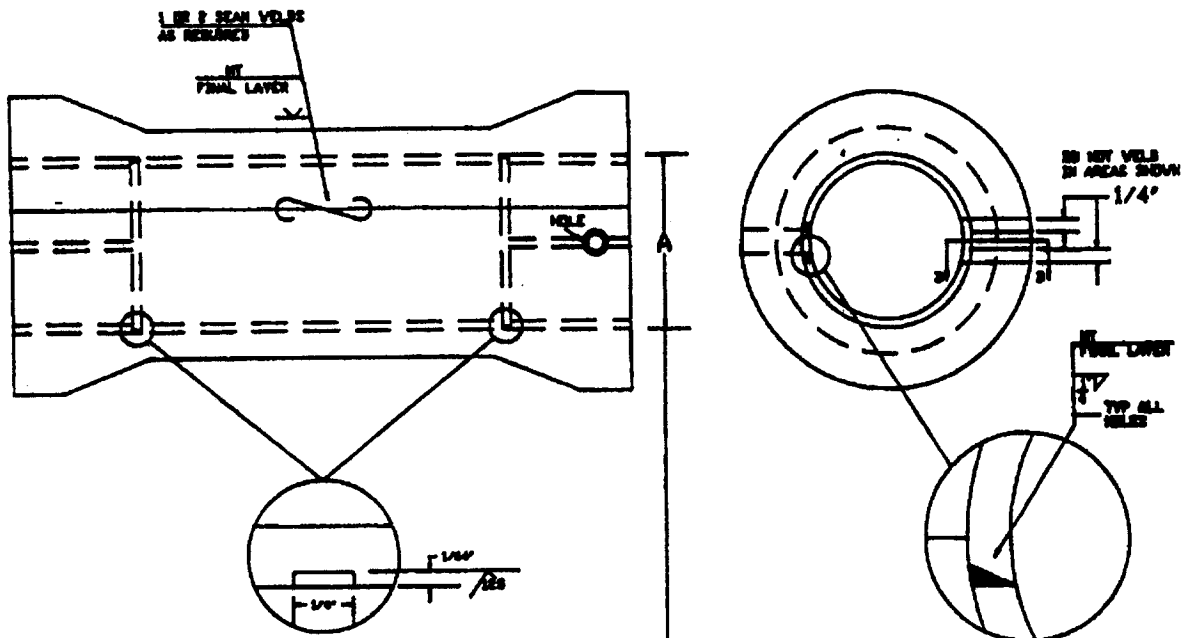

BORE EXISTING CYLINDER TO DIMENSION A TO ACCEPT SLEEVE, PC 1, TO HAVE 0.001 IN. CLEARANCE TO 0.002 IN. INTERFERENCE WITH CYLINDER

DO NOT PREHEAT CYLINDER TO INSTALL SLEEVE

BOTTOM OF GROOVE TO BE SIMILAR TO THAT SHOWN IN SECT. B-B

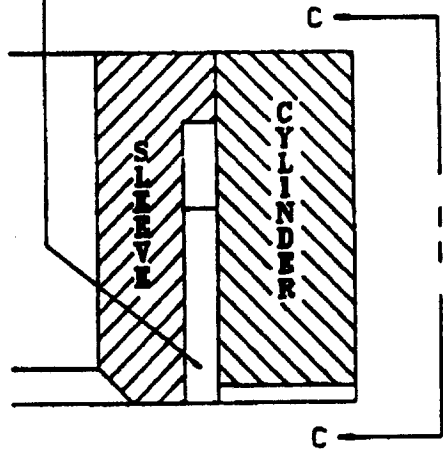

PART. SECT. B - B  
TYP BOTH ENDS

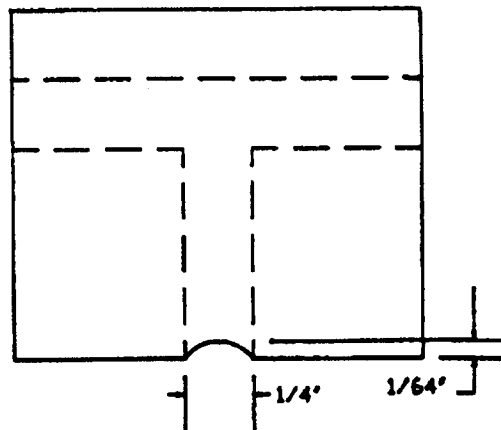

PART. SECT. C - C  
TYP BOTH ENDS

Figure 561-A-1 Steering and Diving Hydraulic Cylinder Internal Sleeving

**APPENDIX B.****STEERING AND DIVING HYDRAULIC CYLINDER HEAD SLEEVING PROCEDURE****561-B.1**

In lieu of manufacturing a new cylinder head to meet acceptance criteria if the hydraulic cylinder is over-bored to restore the finish, the following repair procedure may be used. The procedure requires that the existing cylinder head is machined and a new sleeve is manufactured so that it can be threaded onto the cylinder heads to maintain drawing clearances and seal compression. The sleeve material is to be NI-AL-BRZ, QQ-C-465B alloy C63200. Use [Figure 561-B-1](#), [Table 561-B-1](#) and referenced drawings for details and dimensions. This procedure is only approved for those cylinders which are listed in [Table 561-B-1](#).

## General Notes

1. The following figures were developed to provide instruction for sleeving undersized hydraulic cylinder heads when overboring of the hydraulic cylinder is accomplished by [Appendix A](#).
2. Final dimensions should be machined after installation of the sleeve to the head except for mating surfaces which must be finish machined prior to assembly.
3. Threads between cylinder head and sleeve must be sealed with anaerobic compound per MIL-S-22473, (LOCKTITE GR271) or equivalent as follows: With 1" to 1-3/8" of sleeve internal thread protruding, apply anaerobic compound to remaining internal threads before completing installation.
4. Machine sleeve flush with cylinder head within 0.001" after assembly.
5. Provide a 3/16" wide undercut to root diameter. Radius corners to 0.010".
6. Final dimensions to provide 0.002" to 0.006" diametral clearance with hydraulic cylinder.
7. Threads to be 12UN-3B for sleeve and 12UN-3A for cylinder head.
8. Mating sealing surface between sleeve and cylinder head must be Rhr 32 or smoother on both sleeve and cylinder head.
9. Just prior to installing sleeve on cylinder head, to prevent pinching the o-ring, apply clean 2190 TEP oil to o-ring, o-ring groove and mating sealing surface on cylinder head.
10. Tighten sleeve on cylinder head to provide a metal-to-metal contact fit with cylinder head.
11. The applicable cylinder head drawing, referenced in [Table 561-B-1](#), must be used to provide dimensions not specifically given in the figures.
12. The hydraulic cylinder head must satisfactorily pass a hydrostatic/tightness test.
13. Sleeving of hydraulic cylinder heads must be documented on the ships selected record drawing (SRD) titled, "Steering and Diving Hydraulic System Tables".
14. Tolerances must be as follows, unless indicated in [Figure 561-B-1](#):  
Fractions:  $\pm 1/64$ "  
Decimals:  $\pm 0.010$ "

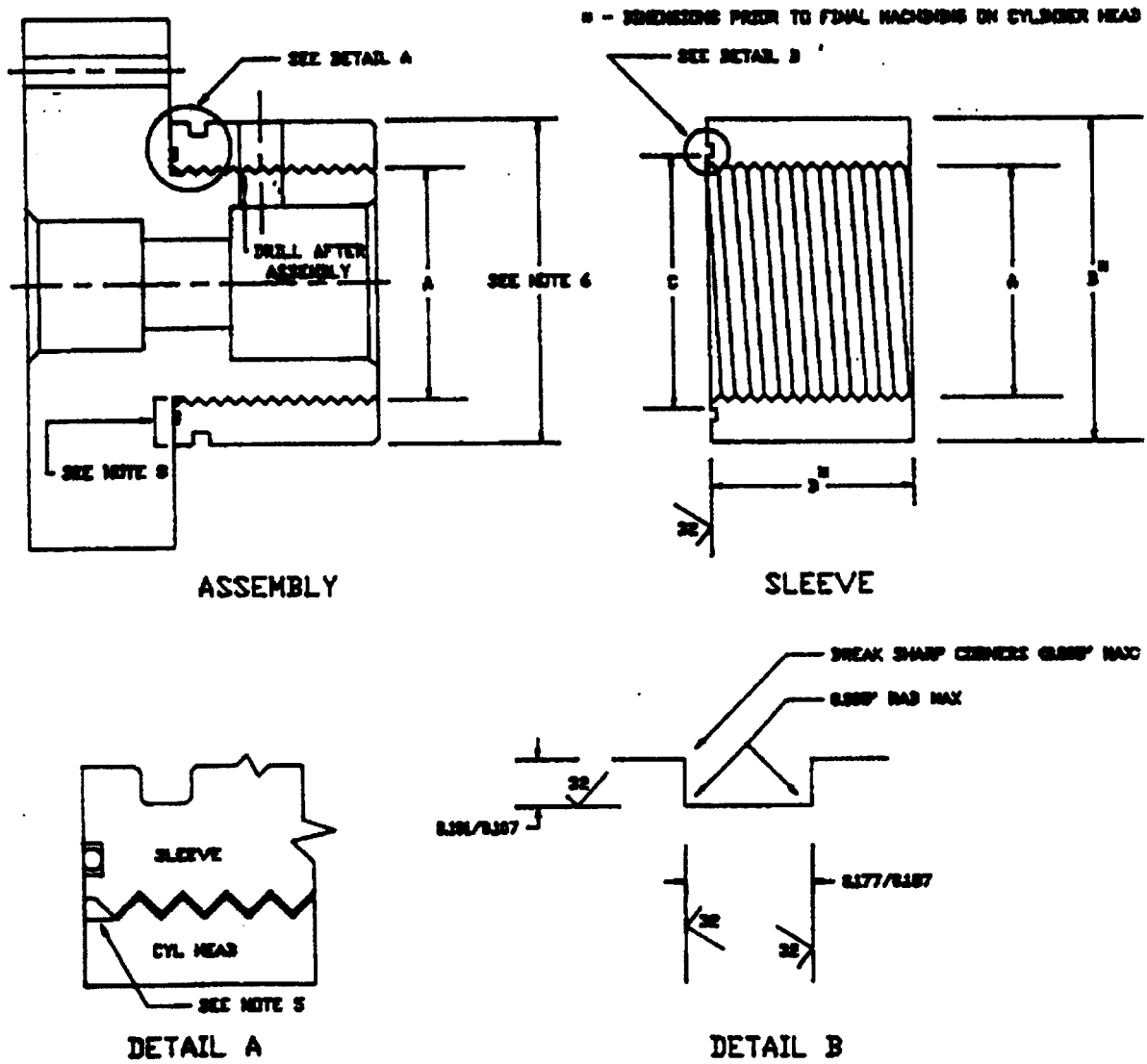

Figure 561-B-1. Typical Hydraulic Cylinder Head Sleeving

Table 561-B-1 DIMENSIONS FOR HYDRAULIC CYLINDER HEAD SLEEVING

STEERING HYDRAULIC CYLINDER HEAD					
CLASS	DIM A	DIM B	DIM C	DIM D	REFERENCE
637	9.000"	10-5/8"	9.500"	4-1/4" 4-3/4"	518-2143669
640	11.500"	13-1/8"	12.000"	4-1/2"	518-2118717
STERN DIVING HYDRAULIC CYLINDER HEAD					
637	7.500"	9-1/8"	8.000"	4-1/2"	518-2143678
640	9.500"	11-1/8"	10.000"	4-1/4"	518-2118725
FAIRWATER DIVING HYDRAULIC CYLINDER HEAD					
637*	10.000"	11-5/8"	10.500"	4-1/4"	518-2143705

**Table 561-B-1** DIMENSIONS FOR HYDRAULIC CYLINDER HEAD

SLEEVING - Continued

<b>STEERING HYDRAULIC CYLINDER HEAD</b>					
<b>CLASS</b>	<b>DIM A</b>	<b>DIM B</b>	<b>DIM C</b>	<b>DIM D</b>	<b>REFERENCE</b>
640	9.000"	11-1/8"	9.500"	5-1/4"	518-2118745

\*Lower hydraulic cylinder head only. Not recommended for upper cylinder head.





**APPENDIX C.****STEERING AND DIVING HYDRAULIC CYLINDER HEAD BUSHING FOR SSN 688 CLASS  
SUBMARINES****561-C.1**

The following repair procedure may be used to restore the hydraulic cylinder head to design operating clearances with the operating rod or piston rod. Machine the existing head and manufacture a bushing that can be placed in the cylinder using [Figure 561-C-1](#) and [Table 561-C-1](#) for details and dimensions. This repair procedure is not applicable to forward cylinder heads on the steering gear, the forward cylinder heads on SSN 718 stern diving or the lower heads on the fairwater diving cylinder heads.

## General Notes

1. Threads between bushing and cylinder head shall be set with anaerobic compound Grade AV or AVV per MIL-S-22473 (LOCTITE GR271) or equivalent.
2. After final machining, drill and tap 1/4-20UNC-3B X 3/8 deep 2 places 180 degrees apart, for hex socket set screw, on Dimension "2". Set with anaerobic compound used in Note 1. Stake in place. All surfaces to be flush or recessed.
3. Machine this face flush with cylinder head mating surface within 0.001".
4. Machine approximately 1/32" longer than recess it is to be screwed into.
5. Bushing material to be NI-AL-BRZ, QQ-C-465B alloy C63200 or equivalent.
6. Set screw material to be NI-CU, QQ-N-281, 1/4-20UNC-3A X 3/8 long.
7. Use referenced drawings for details and dimensions not specifically mentioned in figures.
8. Tolerances shall be as follows:  
Fractions:  $\pm 1/64$ "  
Angles:  $\pm 0$  degrees 30 minutes  
Decimals: As Shown

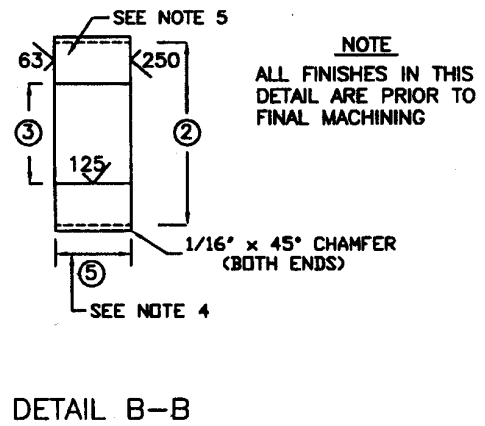
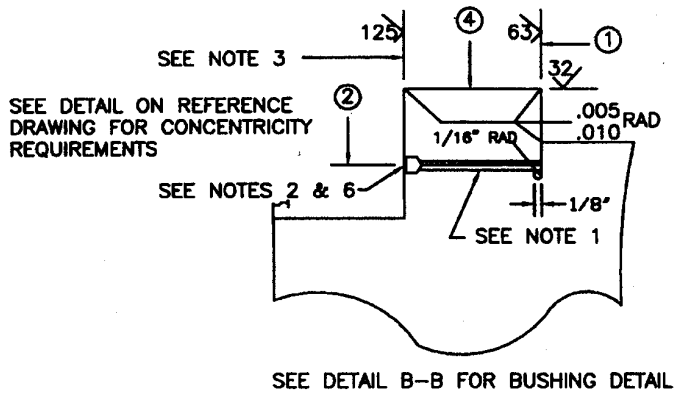
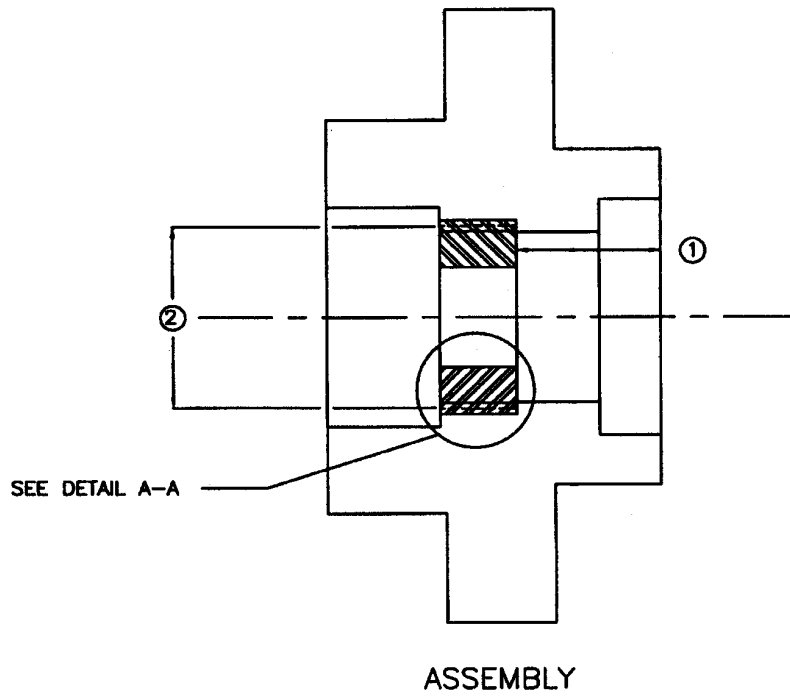

CHANGEDFIGURE

Figure 561-C-1 Typical 688 Class Hydraulic Cylinder Head Bushing

**Table 561-C-1 DIMENSIONS FOR 688 CLASS HYDRAULIC CYLINDER HEAD BUSHING**

<b>STEERING GEAR AFT CYLINDER HEAD</b>					
<b>DIM 1</b>	<b>DIM 2 *</b>	<b>DIM 3</b>	<b>DIM 4</b>	<b>DIM 5</b>	<b>REFERENCE</b>
3.644"/3.746" ***	6"	4-15/16"	5.001 ± 0.001	1-15/16"/1-7/8" ***	518-4457086
<b>STERN DIVING GEAR FORWARD AFT CYLINDER HEAD</b>					
3.644"/4.121" ***	6"	4-7/16"	4.501 ± 0.001	1-13/16"/1-3/8" ***	518-4457083
<b>STERN DIVING GEAR AFT CYLINDER HEAD (SSN718)</b>					
3.531"	4"	3-3/16"	3.251 ± 0.001	1-3/8"	518-5529816
<b>FAIRWATER DIVING GEAR UPPER CYLINDER HEAD</b>					
4.306"/4.492" **	6"	3-15/16"	4.000 ± 0.001	1-1/2/1-1/16" ***	518-4457128

DIM 1 - Reference Dimensions

DIM 2 - Thread Diameter

\* - Threads to be 12UN-2A on bushing and 12UN-2B on cylinder head.

DIM 3 - Nominal inside diameter of unfinished bushing

DIM 4 - Final inside diameter of bushing

DIM 5 - Nominal width of unfinished bushing

\*\*\* - Applicable to reference drawing, revision v and later.

\*\* - Applicable to reference drawing, revision p and later.



**APPENDIX D.****STEERING AND DIVING HYDRAULIC CYLINDER HEAD BUSHING FOR PRE SSN 688 CLASS SUBMARINES****561-D.1**

The following repair procedure may be used to restore the hydraulic cylinder head to design operating clearances with the operating rod or piston rod. Machine the existing head and manufacture a bushing that can be placed in the cylinder head using [Figure 561-D-1](#) and [Table 561-D-1](#) for details and dimensions. This repair procedure is not applicable to forward/lower cylinder heads unless otherwise indicated in [Table 561-D-1](#).

## General Notes

1. Threads to be 12UN-3A on Bushing and 12UN-3B in cylinder head.
2. Threads between bushing and cylinder head shall be set with anaerobic compound Grade AV or AVV per MIL-S-22473 (LOCTITE GR271) or equivalent.
3. After final machining, drill and tap 1/4-20UNC-3B X 3/8 deep 2 places 180 degrees apart, for hex socket set screw, on Dimension "A". Set with anaerobic compound used in Note 2. Stake in place. All surfaces to be flush or recessed.
4. Set screw material to be NI-CU, QQ-N-281, 1/4-20UNC-3A X 3/8 long.
5. Machine bushing cavity in the cylinder head to a depth that is flush with the bottom of the existing packing cavity (Dimension C). Surface finish to be per referenced drawing.
6. Bushing material to be NI-AL-BRZ, QQ-C-465B alloy C63200 or equivalent.
7. Machine this face flush with cylinder head mating surface within 0.001".
8. Use referenced drawings for details and dimensions not specifically mentioned in figures.
9. Tolerances shall be as follows:
  - Fractions:  $\pm 1/64$ "
  - Angles:  $\pm 0$  degrees
  - 30 minutes
  - Decimals: As Shown

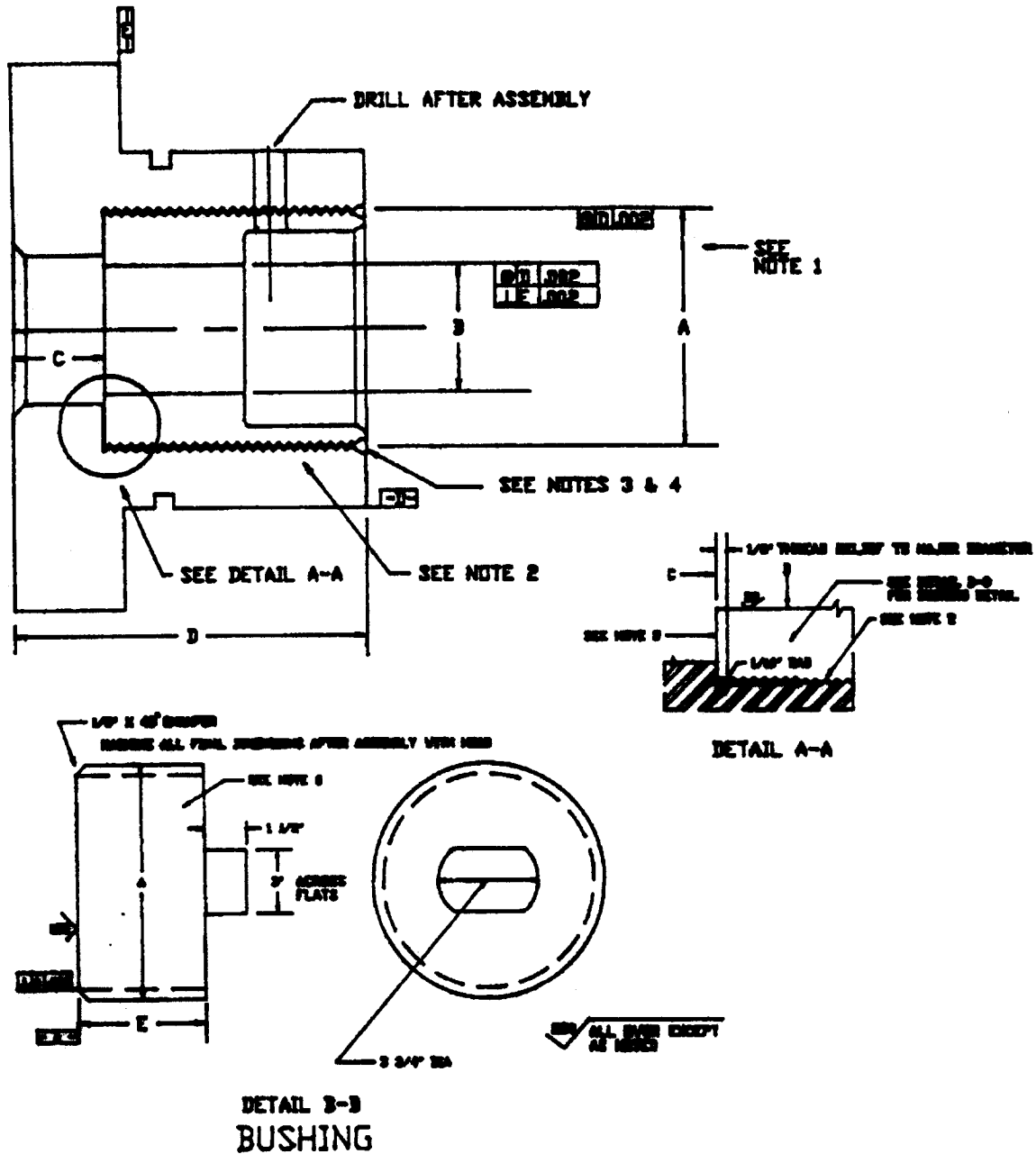

Figure 561-D-1 Typical Pre 688 Class Hydraulic Cylinder Head Bushing

Table 561-D-1 DIMENSIONS FOR PRE 688 CLASS HYDRAULIC CYLINDER HEAD BUSHING

STEERING GEAR						
CLASS	DIM A	DIM B	DIM C	DIM D	DIM E	REFERENCE
637	USE MOD DRAWING SSN 637-518-5308285					
640	8"	5.001 ± 0.001	2.1225 ± 0.0025	7-3/8"	5-5/16"	518-2118717
STERN DIVING GEAR						
CLASS	DIM A	DIM B	DIM C	DIM D	DIM E	REFERENCE
637	USE MOD DRAWING SSN 637-518-5308285					

**Table 561-D-1** DIMENSIONS FOR PRE 688 CLASS HYDRAULIC  
CYLINDER HEAD BUSHING - Continued

<b>STEERING GEAR</b>						
<b>CLASS</b>	<b>DIM A</b>	<b>DIM B</b>	<b>DIM C</b>	<b>DIM D</b>	<b>DIM E</b>	<b>REFERENCE</b>
640	7"	4.501 ± 0.001	2.1225 ± 0.0025	6-7/8"	4-7/8"	518-2118725
<b>FAIRWATER DIVING GEAR</b>						
640	7"	4.501 ± 0.001	2.1225 ± 0.0025	7-7/8"	6-13/16"	518-2118745





**APPENDIX E.****STEERING AND DIVING HYDRAULIC CYLINDER AND FOUNDATION FITTED BOLT BUSHING****561-E.1**

The following methods may be used to repair hydraulic cylinder rams and associated foundations in the way of the fitted bolt holes.

Method 1: Weld repair the hydraulic ram and foundation and re-machine the bores to provide original drawing tolerances with the fitted bolts. This procedure may cause warpage and should be done with caution.

Method 2: Using [Figure 561-E-1](#) and [Table 561-E-1](#) as guides, overbore the fitted bolt holes and manufacture bushings to be installed in the hydraulic ram and foundation bolt holes. Machine bushings to provide original drawing tolerance with fitted bolts.

## General Notes

1. Manufacture bushings from HY-80 barstock, MIL-S-21952.
2. Tack weld each bushing in place on the spotface side of the mounting using a minimum of 1/4" long 1/8" groove welds on each bushing.
3. Touch-up spotfaces, removing the minimum amount of material necessary to smooth off tack welds and restore squareness of spotfaces to the pre-drilled bushing bores.
4. Size bushing OD to provide 0.000" to 0.002" interference fit with the prepared bolt holes.
5. Machine as built diametral clearance just prior to installing fitted bolts to ensure of achieving plan fit.

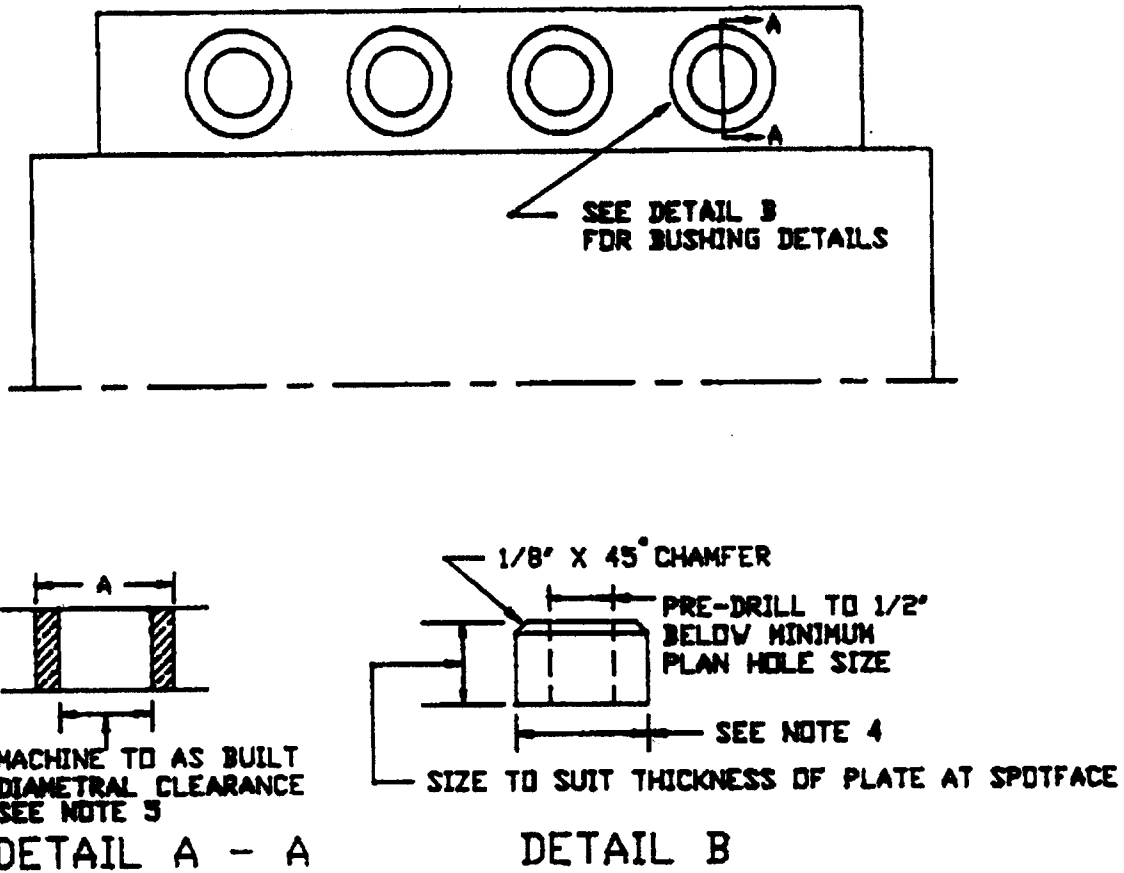

Figure 561-E-1 Steering and Diving Hydraulic Cylinder and Foundation Fitted Bolt Bushing

Table 561-E-1 DIMENSIONS FOR STEERING AND DIVING HYDRAULIC CYLINDER AND FOUNDATION FITTED BOLT BUSHINGS

STEERING GEAR		
CLASS	PLAN DIMENSION	DIMENSION A
637	1.531"	2"
	1.031"	1-5/16"
688	1.500"	1-3/4"
	1.125"	1-5/16"
640	1.781"	2-1/8"
	1.156"	1-1/2"
STERN DIVING GEAR		
637	1.406"	1-13/16"
	1.031"	1-5/16"
688	1.500"	1-3/4"
	1.250" <sup>#</sup>	1-1/2"
640	1.531"	2"
	1.031"	1-5/16"
FAIRWATER DIVING GEAR		
637	1.531"	2"
688	N/A	N/A

**Table 561-E-1** DIMENSIONS FOR STEERING AND DIVING  
HYDRAULIC CYLINDER AND FOUNDATION FITTED BOLT BUSHINGS

- Continued

<b>STEERING GEAR</b>		
<b>CLASS</b>	<b>PLAN DIMENSION</b>	<b>DIMENSION A</b>
640	1.531"	2"

#- Applicable to SSN 718



**APPENDIX F.****STEERING AND DIVING GUIDE CYLINDER COVER BUSHING****561-F.1**

The following repair procedure may be used to restore the guide cylinder cover to design operating clearances with the operating rod. Machine the existing cover and manufacture a bushing that can be placed in the cover using [Figure 561-F-1](#) and [Table 561-F-1](#) for details and dimensions.

## General Notes

1. Thread fit of "A" on Bushing and bore "B" in cylinder head.
2. Threads between bushing and guide cylinder cover shall be set with anaerobic compound Grade AV or AVV per MIL-S-22473 (LOCTITE GR271) or equivalent.
3. After final machining, drill and tap 1/4-20UNC-3B X 3/8 deep 2 places 180 degrees apart, for hex socket set screw, on Dimension "A". Set with anaerobic compound used in Note 2. Stake in place. All surfaces to be flush or recessed.
4. Set screw material to be NI-CU, QQ-N-281, 1/4-20UNC-3A X 3/8 long.
5. Machine this face flush with guide cylinder cover mating surface within 0.001".
6. Bushing material to be NI-AL-BRZ, QQ-C-465B alloy C63200 or equivalent.
7. Surface finish to be per referenced drawing.
8. Use referenced drawings for details and dimensions not specifically mentioned in the figures.
9. Tolerances shall be as follows:
  - Fractions:  $\pm 1/64$
  - Angles:  $\pm 0$  degrees
  - 30 minutes
  - Decimals: As Shown

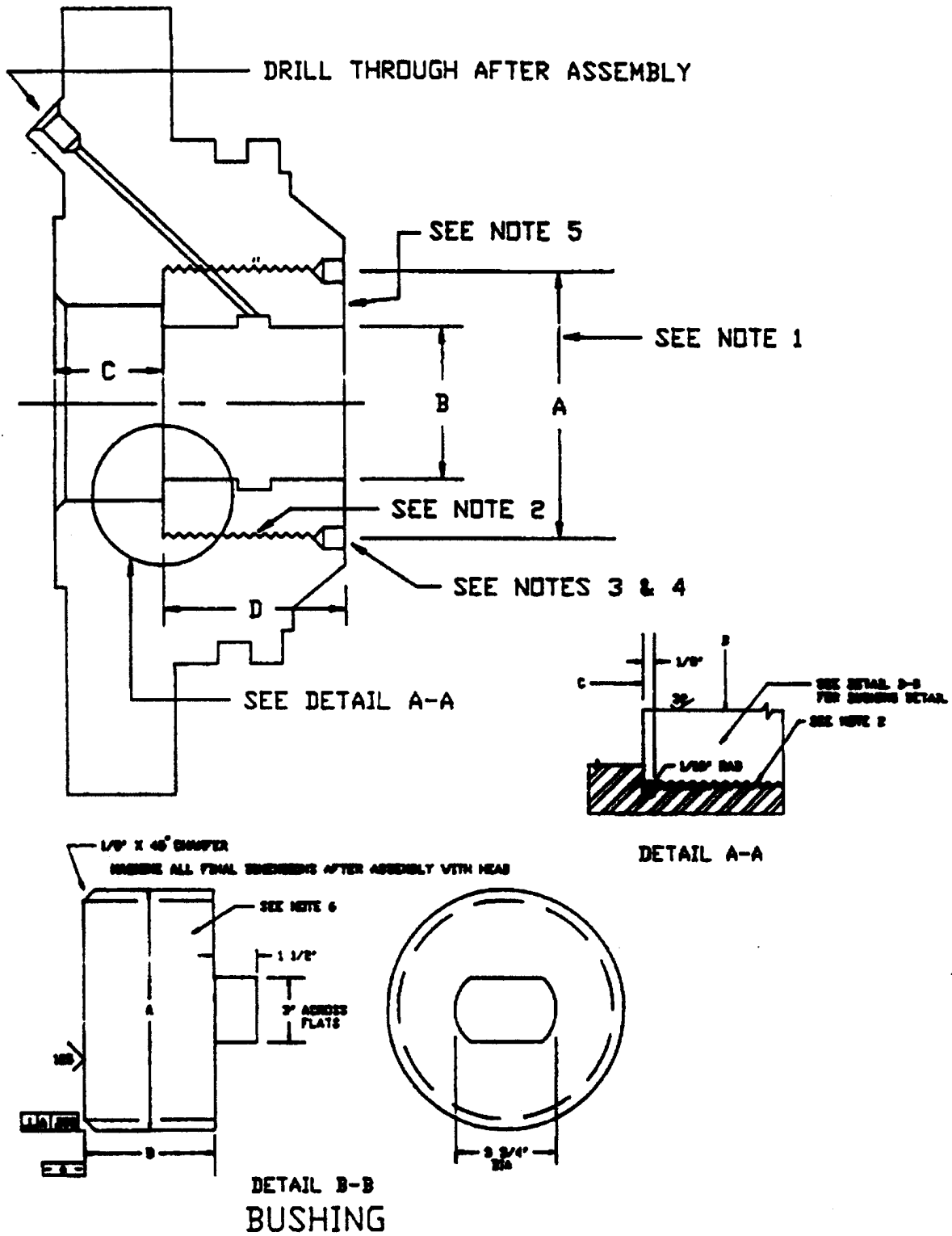

Figure 561-F-1 Guide Cylinder Cover Bushing

**Table 561-F-1 DIMENSIONS FOR STEERING AND DIVING GUIDE  
CYLINDER COVER BUSHING**

<b>STEERING GEAR</b>					
<b>CLASS</b>	<b>DIM A</b> *	<b>DIM B</b>	<b>DIM C</b>	<b>DIM D</b>	<b>REFERENCE</b>
637	USE DRAWING 518-5157643 AS REFERENCE GUIDE				
640	6-1/2"	5.010 ± 0.001	1.8725 ± 0.0005	3-1/8"	518-2118720
<b>STERN DIVING GEAR</b>					
637	USE DRAWING 518-5157643 AS REFERENCE GUIDE				
640	6-1/2"	4.513 ± 0.001	1.8725 ± 0.0005	3-1/8"	518-2118728
<b>FAIRWATER DIVING GEAR</b>					
640	6-1/2"	4.5075 ± 0.0015	1.873 ± 0.002	2-5/8"	518-2118744

\* - Dimension for 12UN-3 threads.





**APPENDIX G.****STEERING AND DIVING GUIDE CYLINDER PISTON BUSHING****561-G.1**

The following repair procedure may be used to restore the clearances between the guide cylinder piston and the guide cylinder pin. Machine the existing guide cylinder piston and manufacture new bushings which would be installed into the guide cylinder piston. Bushing material to be NI-AL-BRZ, QQ-C-465B alloy C63200 or equivalent. Use [Figure 561-G-1](#), [Table 561-G-1](#), and referenced drawings for details and dimensions.

Tolerances shall be as follows:

Fractions:  $\pm 1/64$

Angles:  $\pm 0$  degrees

30 minutes

Decimals: As Shown

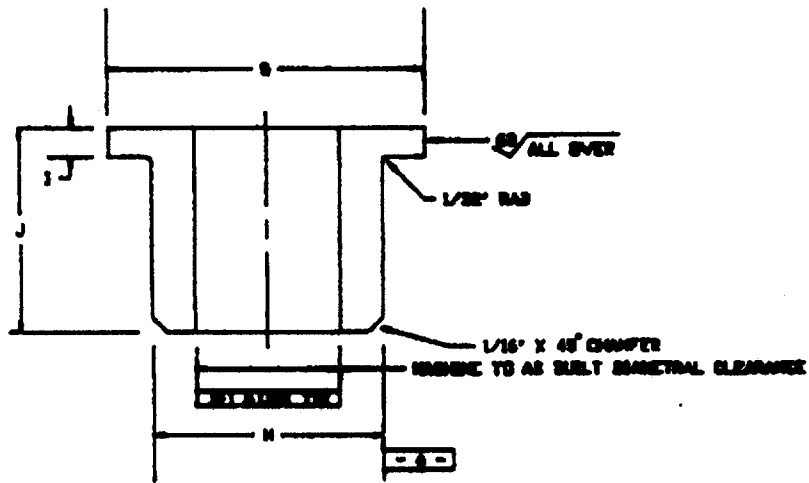
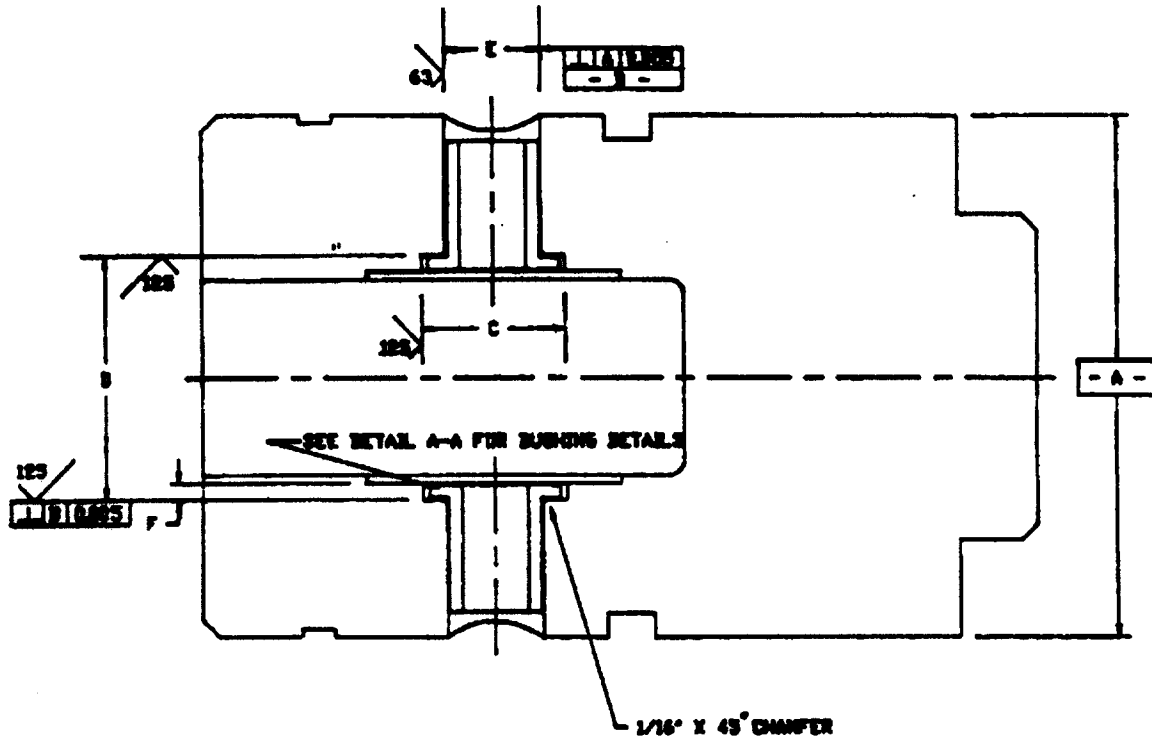

DETAIL A - A

Figure 561-G-1 Guide Cylinder Piston Bushing

**Table 561-G-1** DIMENSIONS FOR GUIDE CYLINDER PISTON  
BUSHING STEERING GEAR

CL	DIM C	DIM D	DIM E	DIM F	DIM G	DIM H	DIM I	DIM J	REFERENCE
637	5-7/8"	6-3/4"	5.003 ± 0.001	3/8"	5-3/4"	5.002 ± 0.001	11/32"	2-1/8"	518-2143671
688	6-3/8"	6-5/16"	5.502 ± 0.001	3/8"	6-1/4"	5.5025 ± 0.0005	11/32"	2-9/16"	518-4457076
640	6-3/8"	8-1/4"	5.751 ± 0.001	3/8"	6-1/4"	5.7515 ± 0.0005	11/32"	2-15/16"	518-2118719
<b>STERN DIVING GEAR</b>									
637	5-7/8"	6-3/4"	5.003 ± 0.001	3/8"	5-3/4"	5.0035 ± 0.0005	11/32"	2-1/2"	518-2143680
688 *	5-5/8"	6-5/16"	4.752 ± 0.001	3/8"	5-1/2"	4.7525 ± 0.0005	11/32"	2-9/16"	518-4457080
718 **	3-1/2"	4-1/2"	3.252 ± 0.001	3/8"	3-3/4"	3.2525 ± 0.0005	11/32"	2-11/16"	518-5529809
640	6-3/8"	6-3/4"	5.7505 ± 0.0005	3/8"	6-1/4"	5.7515 ± 0.0005	5/16"	2-1/8"	518-2118727
<b>FAIRWATER DIVING GEAR</b>									
637	4-7/8"	5-3/8"	4.0025 ± 0.0015	3/8"	4-3/4"	4.0035 ± 0.0005	11/32"	1-5/8"	518-2047378
640	6"	6-5/16"	4.5005 ± 0.0005	3/8"	5-5/8"	4.5015 ± 0.0005	13/32"	1-15/16"	518-2118743

\* - Applicable to SSN 718 No. 2 Guide Piston.

\*\* - Applicable to SSN 718 No. 1 Guide Piston ONLY.



**APPENDIX H.****STEERING AND DIVING TILLER ARM BUSHING****561-H.1**

The following repair procedure may be used to restore the plan clearances between the tiller arm and tiller pin. This procedure allows the overboring of the tiller arms to allow a bushing to be installed to restore the pin clearance. For those classes of submarines that do not have bushings installed during new construction, do not have new construction drawings that could be utilized or do not have ShipAlts that would accomplish the bushing, use [Figure 561-H-1](#) and [Table 561-H-1](#) for details and dimensions for adding bushings to the tiller arms. OD's of the bushings in [Table 561-H-1](#) may not be increased. Bushing material to be QQ-C-465B alloy C63200 or equivalent.

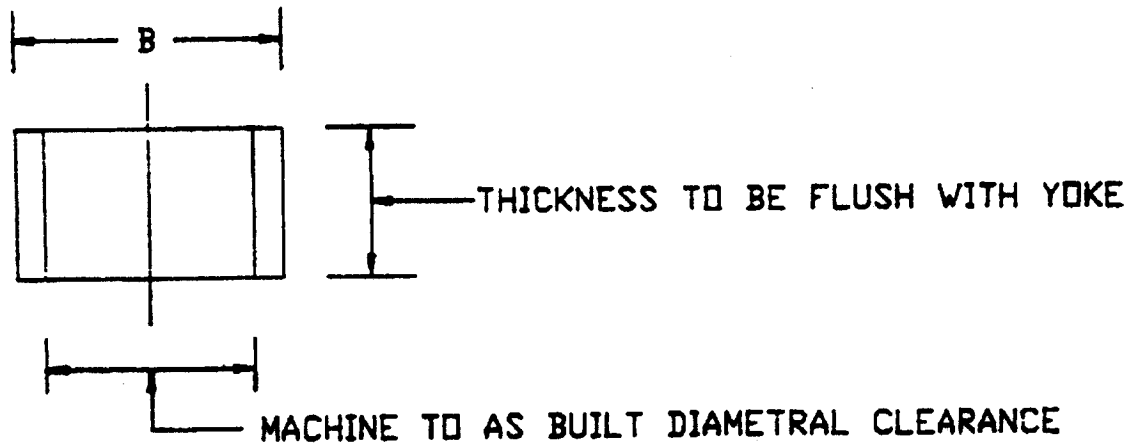
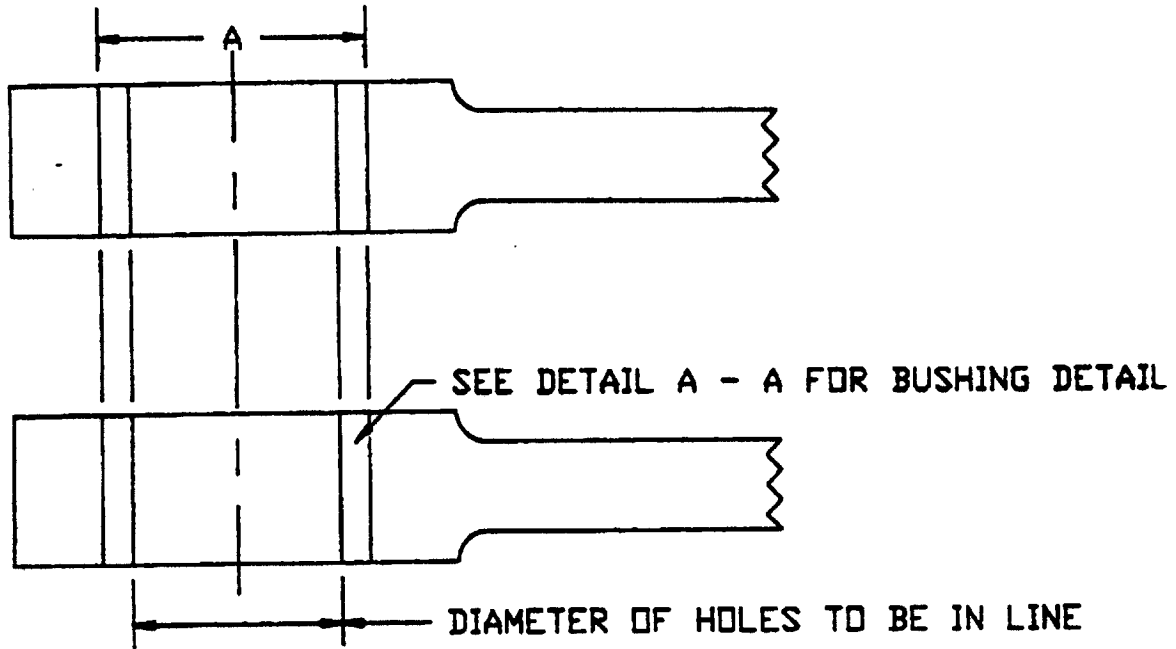

## DETAIL A - A

Figure 561-H-1 Steering and Diving Tiller Arm Bushing

Table 561-H-1 DIMENSIONS FOR STEERING AND DIVING TILLER ARM BUSHING STERN GEAR

SHIP CLASS	DIM A	DIM B	REFERENCE
640	5.750/5.751	5.751/5.752	518-2452193 518-2116832 518-2437193

## APPENDIX I

### INSTALLATION OF SELF-LUBRICATED BEARINGS IN STEERING AND DIVING OPERATING GEAR

#### 561-I.1 GENERAL INFORMATION.

The following repair procedure provides NAVSEA directives on methods for replacement of metal bearing components with self-lubricated bearing materials in submarine steering and diving operating gear. This procedure is intended to supplement but not supersede approved NAVSEA drawings and planning yard engineering notices for steering and diving self-lubricated bearing installation. These procedures apply to repair of SSN 688 Class and SSBN 726 Class submarine steering and diving operating gear bearings.

561.I.1.1 Summary of Bearing Repairs. Repairs incorporating self-lubricated bearings have been developed for the major bearings in SSN 688 Class and SSBN 726 Class submarine steering and diving system operating gear. These bearings include the following:

- a. Connecting rod, tiller arm and guide piston bushings and thrust washers
- b. Guide piston staves
- c. Through-hull rod support and hull penetration bearings
- d. Fairwater diving plane stock bearings
- e. Stern diving plane stock bearings
- f. Stern diving plane pintle bearings
- g. Rudder stock bearings
- h. Rudder carrier bearings

Specific SSN 688 Class and SSBN 726 Class submarine steering and diving bearing replacements covered by this document are shown in [Tables 561-I-1](#) and [561-I-2](#).

**Table 561-I-1** SSN 688 Class Submarine Steering & Diving Bearing Replacements

Application	Component	Materials	
		Existing	Replacement <sup>(1)</sup>
Connecting Rod Bearings	Connecting Rod Bushing	Ni-Al-Brz	Self-Lube Bearing
	Tiller Arm Bushing	Ni-Al-Brz	Self-Lube Bearing
	Guide Piston Bore Bushing	None	Self-Lube Bearing
	Connecting Rod Thrust Washers	Naval Brass, 464	UHMWPE
Guide Piston	Guide Piston Staves	Ni-Al-Brz (Piston)	Orkot
	Guide Piston Pin End Caps	Monel Retainer	UHMWPE
Through-Hull Rod Support Bearings	Hull Gland Bearing	Bronze (Gun Mtl)	Self-Lube Bearing <sup>(3)</sup>
	Rod Support Bearing Staves	Delrin "AF"	UHMWPE, Orkot
Fairwater Stock Bearings	Stock Sleeves	Stellite, Alloy 21	K-Monel
	Bushings (Retainers)	H-Monel, Alloy 16	(Reused)
	Stock Bearings	Stellite, Alloy 20	Self-Lube Bearing
	Keeper Rings	Al-Mn-Brz	UHMWPE, Orkot

**Table 561-I-1** SSN 688 Class Submarine Steering & Diving Bearing  
Replacements - Continued

Application	Component	Materials	
		Existing	Replacement <sup>(1)</sup>
Stern Plane Stock Bearings	Stock Sleeves	Stellite, Alloy 21	K-Monel
	Bushings	Stellite, Alloy 20	Self-Lube Bearing
	Thrust Bearing on Clamp Ring	None	UHMWPE, Orkot
Pintle Bearings	Spherical Bearing Ring	Stellite, Alloy 20	Self-Lube Bearing <sup>(2)</sup>
	Bearing Sleeve	Stellite, Alloy 21	K-Monel
	Bearing Retainer	H-Monel, Alloy 16	NiAlBrz
Rudder Stock and Carrier Bearings	Spherical Bearing Rings	Stellite, Alloy 20	Self-Lube Bearing <sup>(2)</sup>
	Stock Sleeves	Stellite, Alloy 21	K-Monel
	Stock Bushings (Retainers)	H-Monel, Alloy 16	NiAlBrz
	Carrier Bearing Collar	H-Monel, Alloy 16	Karon-V on K-Monel
	Carrier Bearing Lower Washer	Stellite, Alloy 21	Inconel 718
	Carrier Bearing Upper Washer	Stellite, Alloy 20	Karon-V on K-Monel

<sup>(1)</sup>Contact NAVSEA 92T for list of self-lubricated bearing materials that are qualified for use.

<sup>(3)</sup>Self-lubricated bearings are not to be used for hull gland bearing in fairwater diving gear.

<sup>(2)</sup>Replacements utilize journal type bearings instead of the three piece spherical bearing.

**Table 561-I-2** SSBN 726 Class Submarine Steering & Diving Bearing  
Replacements

Application	Component	Materials	
		Existing	Replacement <sup>(1)</sup>
Connecting Rod Bearings	Connecting Rod Bushing	Stellite Alloy 20	Self-Lube Bearing
Bearing	Tiller Arm Bushing	Ni-Al-Brz	Self-Lube Bearing
	Guide Piston Bore Bushing	Stellite Alloy 20	Self-Lube Bearing
	Connecting Rod Thrust Washers	Gun Metal (Brz)	UHMWPE
	Tiller and Piston Pin Sleeves	Stellite Alloy 21	Removed
Guide Piston	Guide Piston Staves	Ni-Al-Brz (Piston)	UHMWPE, Orkot
	Piston Pin End Caps	Delrin	NiAlBrz, UHMWPE
Through-Hull Rod Support Bearings	Hull Gland Bearing	Bronze (Gun Mtl)	Self-Lube Bearing <sup>(3)</sup>
	Coupling and Bearings	None	Orkot
Fairwater Stock Bearings	Stock Sleeves	Stellite, Alloy 20	K-Monel
	Bushings (Retainers)	H-Monel, Alloy 16	NiAlBrz
	Spherical Bearing Ring	Stellite, Alloy 21	Self-Lube Bearing <sup>(2)</sup>
	Keeper Rings	Ni-Al-Brz	UHMWPE
Stern Plane Stock Bearings	Stock Sleeves	Stellite, Alloy 21	K-Monel
	Bearings	Stellite, Alloy 20	Orkot
	Retaining Plate	None	Monel
	Thrust Bearing on Clamp Ring	None	UHMWPE
Pintle Bearings	Spherical Bearing Ring	Stellite, Alloy 20	Self-Lube Bearing <sup>(2)</sup>
	Bearing Sleeves	Stellite, Alloy 21	K-Monel
	Bearing Retainers	H-Monel, Alloy 16	NiAlBrz



**Table 561-I-2** SSBN 726 Class Submarine Steering & Diving Bearing  
Replacements - Continued

Application	Component	Materials	
		Existing	Replacement <sup>(1)</sup>
Rudder Stock and Carrier Bearings	Spherical Bearing Ring	Stellite, Alloy 20	Self-Lube Bearing <sup>(2)</sup>
	Stock Sleeves	Stellite, Alloy 21	K-Monel
	Stock Bushings (Retainers)	H-Monel, Alloy 16	NiAlBrz
	Carrier Bearing Collar	H-Monel, Alloy 16	Karon-V on K-Monel
	Carrier Bearing Lower Washer	Stellite, Alloy 21	Inconel 718
	Carrier Bearing Upper Washer	Stellite, Alloy 20	Karon-V on K-Monel

<sup>(1)</sup>Contact NAVSEA 92T for list of self-lubricated bearing materials that are qualified for use.

<sup>(3)</sup>Self-lubricated bearings are not to be used for hull gland bearing in fairwater diving gear.

<sup>(2)</sup>Replacement bearing designs utilize journal type bearings instead of three piece spherical bearings.

561-I.1.2 Qualified Bearing Materials. NAVSEA has implemented a continuing program to evaluate self-lubricated bearing materials. Evaluation of these materials has included engineering analyses, wear tests, and trial shipboard installations. Materials have been selected from vendors with commercially available products. The key requirements for material selection include:

- Commercial, off-the-shelf material.
- No lubrication requirements.
- Low water absorption and dimensional stability in seawater.
- Low deformation and creep under design loading.
- High wear resistance and low coefficient of friction.
- Compatible with mating materials in seawater environment.

Table 561-I-3 shows qualified materials for specific types of steering and diving gear bearing applications and typical operating conditions for these applications. Contact NAVSEA 92T for the latest list of qualified self-lubricated bearing materials. Table 561-I-4 provides a comparison of selected material properties and other information for these qualified materials as well as for others which are potentially suitable for submarine steering and diving gear applications.

**Table 561-I-3** Qualified Self-Lubricated Bearing Materials

Bearing Application	Qualified Materials	Maximum Contact Pressure (psi)	Maximum Velocity (fpm)	Angle of Oscillation
Stock Bearings	Tuflite, Karon V Composite, Orkot TXM	5,000	less than 10	35°
Connecting Rod Bearings	Tuflite, Karon V Composite	15,000	less than 10	15°
Guide Piston Staves	Orkot TLM, Thordon SXL, UHMWPE*	300 to 1,000 depending on system	10 to 20	N/A
Thrust Washer	UHMWPE	up to 100	less than 10	15°
Keeper Ring	Orkot TLM, UHMWPE*	up to 1,000 approx.	less than 10	35°

\*UHMWPE only to be used for contact pressure less than 300 psi.

**Table 561-I-4** Characteristics of Selected Self-lubricated Bearing Materials

Manufacturer	Materials	Description	Ultimate Compressive Strength (psi)	Bearing <sup>(1)</sup> Pressure Limit (psi)	Friction <sup>(2)</sup> Coefficient	Water Swell (% by Volume)	Thermal Expansion Coefficient (in/in/°F)
Poly-Hi Polymer Corp Keltrol	Tivar 1000 Ultra-Wear Tuflar	Ultrahigh molecular weight polyethylene (UHMWPE)	3,800 - 5,500	300 (static)	0.10 - 0.15	Negligible	$1 \times 10^{-4}$
Thordon	Thordon SXL and HPSXL <sup>(5)</sup>	Homogenous thermoset elastomer (SXL); HPSXL is higher strength	5,500	1,250 10,000 for HPSXL	0.08 - 0.15	1.3	$8 - 12 \times 10^{-5}$
Rexnord	Tuflite (Duralon)	Teflon/dacron fabric backed by filament wound fiberglass epoxy	60,000	20,000	0.08 - 0.13	Negligible	$7 \times 10^{-6}$
Orkot	TLM and TXM?Marine	Polyester (TLM) or polyester/teflon (TXM) fabric in thermoset polyester resin atrix with MoS <sub>2</sub>	50,000	15,000	0.08 - 0.15	0.1 <sup>(3)</sup>	$2 - 4 \times 10^{-5}$ 5 - $6 \times 10^{-5}$ (hoop/radial)
Kamatics	Karon V	Liner of polyester resin with teflon filler backed by filament wound fiberglass epoxy	50,000 <sup>(4)</sup>	20,000	0.06 - 0.08	0.2 (backing)	$1.6 \times 10^{-5}$ 2.6 x $10^{-5}$ (hoop/radial)
Garlock Bearings	Gar-Fil <sup>(5)</sup> and Gar-Max <sup>(5)</sup>	Teflon tape or wound teflon fiber backed by filament wound fiberglass epoxy	55,000 to 60,000	20,000 to 30,000	0.03-0.15	n/a	$7 \times 10^{-6}$
Tri-Star Plastics	ACM L2 <sup>(5)</sup>	Polyester fabric in thermoset polyester resin matrix with MoS <sub>2</sub>	60,000	n/a	0.05-0.08	0.1	$3 \times 10^{-5}$ 6 x $10^{-5}$ (hoop/radial)
Tenmat	T814 <sup>(5)</sup>	Fabric reinforced phenolic	36,250	9,000	0.06 - 0.09	0.35	$2.5 \times 10^{-5}$ 2.8 x $10^{-5}$ (hoop/radial)

<sup>(1)</sup>Bearing pressure limit is vendor recommended value to limit either creep or wear.

<sup>(2)</sup>Coefficient of friction is dynamic, dry, on polished steel.

<sup>(5)</sup>Material not yet tested by NAVSEA 92T for steering and diving gear service.

<sup>(3)</sup>Orkot water swell is percent change in linear dimensions after 9 months.

<sup>(4)</sup>Karon ultimate strength is for liner material. Ultimate strength for fiberglass backing is 75,000 psi.

For most steering and diving gear self-lubricated bearings, the mating metal surface is intended to be K-Monel, a nickel-copper-aluminum alloy commercially referred to as Monel Alloy K-500. Because of its high strength and good corrosion resistance, K-Monel is widely used for load carrying members in seawater exposed systems. K-Monel has adequate hardness (Rockwell C 25 to 27) for use as a mating surface with self-lubricated bearing materials, and may be used to replace original Stellite (cobalt-chromium-tungsten alloy) bearing components.

**561-I.1.3 Bearing Sizing Guidance.** The bearing repairs described in this procedure provide essentially the same form, fit, and function as the original bearing designs. However, because of the different material properties, it is usually necessary to design the self-lubricated bearing parts with dimensions that differ from the original design dimensions. Increased interference fits are required because self-lubricated bearing materials are generally softer than metals. Self-lubricated bearing materials can also undergo more substantial dimensional changes than metals due to water absorption (swell) and thermal expansion and contraction. Consequently, interference fits must be designed to ensure that adequate retention is provided at low temperature. Also, clearances may need to be increased to provide allowance for thermal expansion and water swell to prevent binding of mating bearing parts. These effects are described below.

**561-I.1.3.1 Water Swell.** The effect of water swell is to increase the size of the bearing part as shown below (see [Figure 561-I-1](#)). For bushings, the OD of the part is constrained, and swell causes the thickness to expand, reducing the bearing clearance. For free floating spherical bearing rings, neither the OD nor the ID is constrained, and the effect of swell is more pronounced since both the OD and the thickness can expand. The magnitude of the water swell effect must be evaluated for the geometry and dimensions of each bearing application.

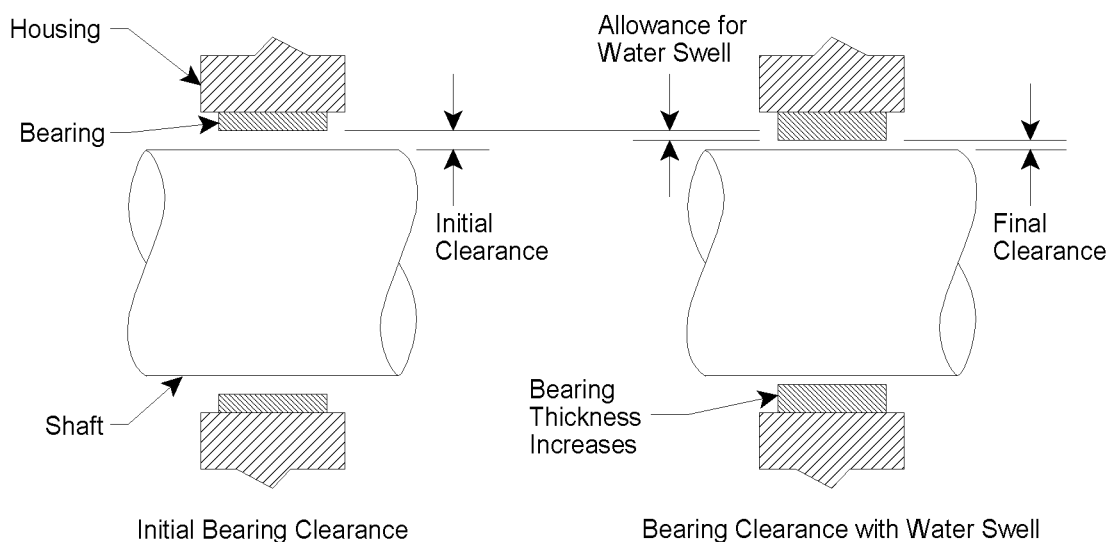

Figure 561-I-1 Effect of Water Swell on Bearing Clearance

**561-I.1.3.2 Differential Thermal Expansion.** Thermal expansion and contraction can occur since the design operating temperature range is 28°F to 95°F for steering and diving components operating in seawater. Assuming the bearing components are assembled at an intermediate temperature (for example, room temperature at 70°F), the bearing dimensions will change at the extremes of the design temperatures. Differential thermal expansion or contraction between the housing and other mating bearing components may result in changes in the clearance or interference fit as shown below (see [Figure 561-I-2](#)).

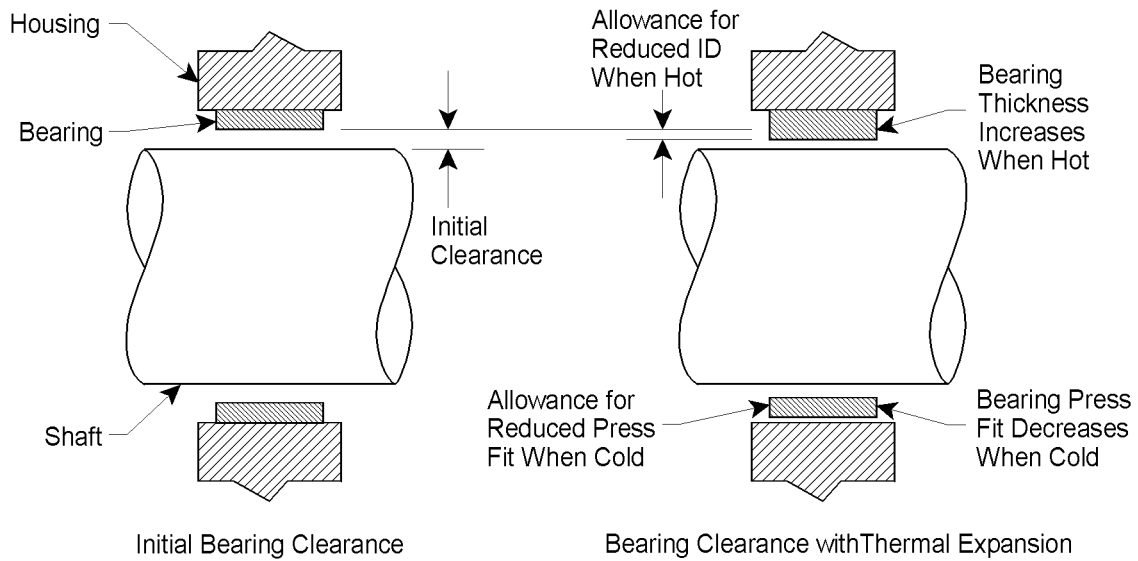
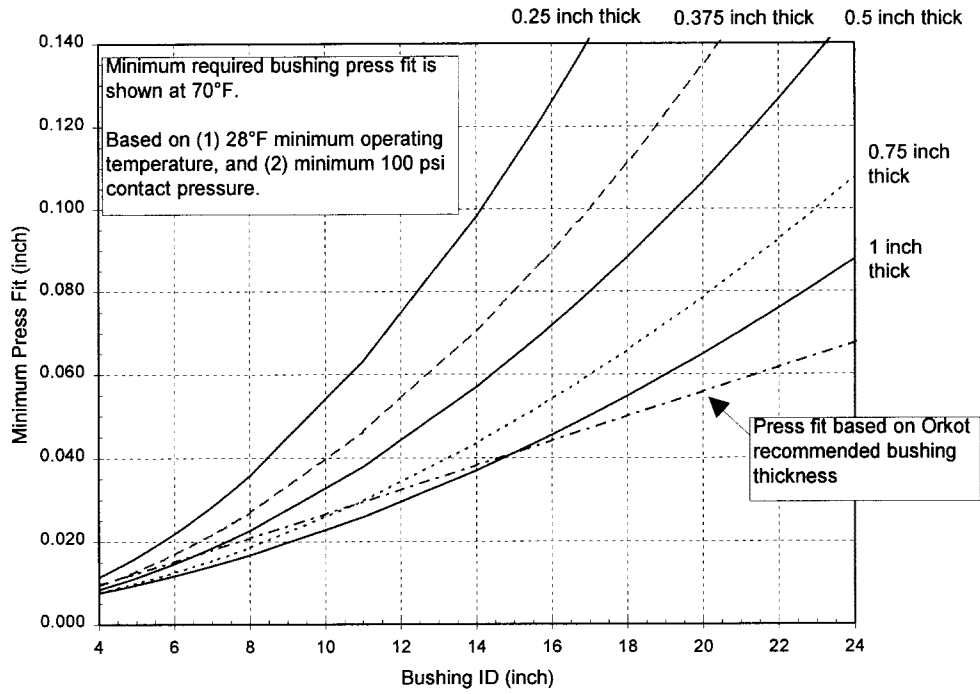

Figure 561-I-2 Effect of Thermal Expansion on Bearing Clearance

NAVSEA has evaluated these effects and has established appropriate interference fits and clearances for the different qualified materials. As an example, the recommended interference fits for a range of diameters and thicknesses are shown below for two different self-lubricated bearing materials. The necessary interference fits and clearances are reflected in the NAVSEA drawings and planning yard engineering notices that have been prepared for most SSN 688 and SSBN 726 Class submarine steering and diving gear bearings. For bearings not covered by these documents, a computerized bearing sizing program has been developed to help in establishing the necessary bearing size.

It is important to note that bearings are always specified with the OD and ID before installation; these dimensions account for the reduction in the bearing ID due to the interference fit.

**Orkot TXM/TLM Bushing Press Fit Requirements**



Recommended Interference Fits for Orkot TXM

**Tuflite Bushing Press Fit Requirements**

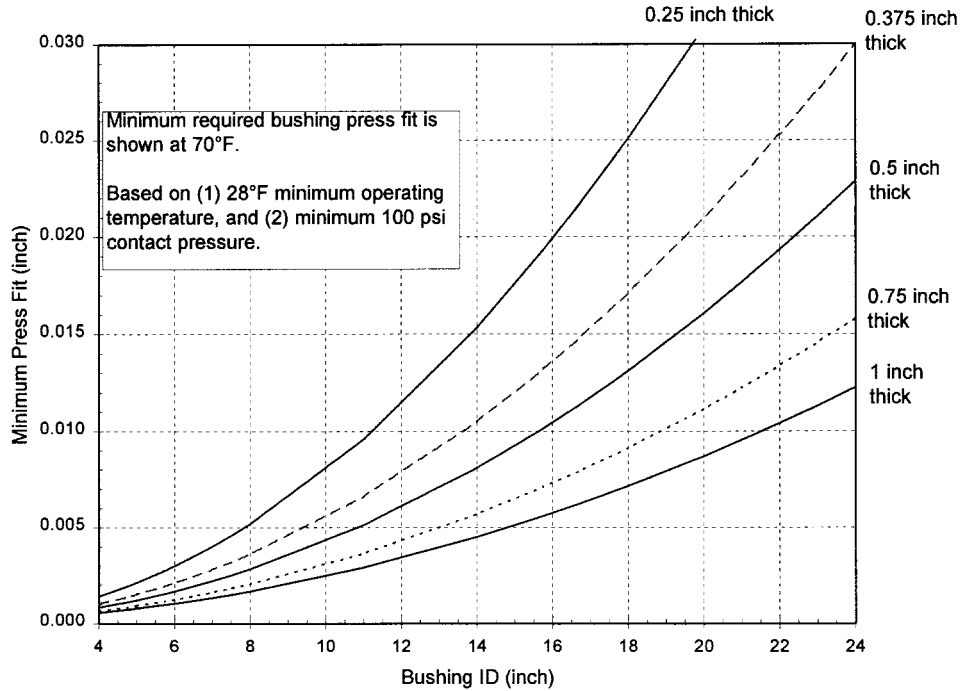

Recommended Interference Fits for Tuflite.

561-I.1.3.3 Bearing Replacement Planning. These bearing repairs are to be implemented as part of any refurbishment or repair activities required to resolve inspection findings, or as part of other overhaul activities for the applicable steering or

diving control surface. For some bearings, the extent of the material replacements can affect work on other components or require additional lead time for component fabrication or machining. Consequently, proper planning is required to ensure schedule requirements are not jeopardized while implementing the modifications described in this chapter.

### 561-I.2 GENERAL REPAIR REQUIREMENTS.

561-I.2.1 Criteria For Repair. Worn, damaged, out-of-specification, or noise generating bearing components shall be repaired. Repairs shall include the self-lubricated bearing modifications described in this procedure. Generally, the criteria to initiate repairs during overhaul is the applicable Maintenance Standard for overhaul of the control surface operating gear, and during the operating cycle it is NSTM Chapter 561 bearing clearance limits. For each operating gear linkage, the extent of bearing components replaced will be based on the scope and type of work being performed to correct worn/damaged components.

561-I.2.2 Scope of Repair. Self-lubricated bearing installations shall be done in the sets described in the subsequent paragraphs of this procedure. When repairing a particular steering and diving system component, ensure all the associated bearing components in the set are repaired or replaced. If the scope of work does not permit the replacement of all components specified in the set, contact NAVSEA 92T for further guidance.

561-I.2.3 Bearing Materials. Bearing materials shall be suitable for the intended application and shall be qualified as described in [paragraph 561-I.1.2](#) or per Commercial Item Description (CID) A-A-50602. Contact NAVSEA 92T for the list of qualified bearing materials if approved NAVSEA drawings or planning yard engineering notices do not specify the bearing materials to be used.

Self-lubricated bearing manufacturers qualified for certain applications include the following:

#### Qualified Bearing Manufacturers

Rexnord Corporation (Duralon/Tuflite)  
2324 Curtiss Street  
Downers Grove, IL 60515  
Phone (630) 969-1770  
Fax (630) 969-8752

Orkot Composites  
2535 Prairie Road  
Eugene, OR 97402  
Phone (541) 688-5529  
(541) 688-2079

Kamatics Corporation (Karon)  
P.O. Box 3  
1330 Blue Hills Avenue  
Bloomfield, CT 06002  
Phone (860) 683-2856  
Fax (860) 683-2942

561-I.2.4 Packaging, Labeling, And Handling Requirements. Packaging, Labeling, And Handling Requirements. Packaging and marking of replacement bearing components shall be per Commercial Item Description (CID) A-A-50602. As a minimum, all procured materials shall be labeled with appropriate identification. Individual parts shall be identified by the applicable drawing and item number. This identification shall be attached to each component or its container (e.g. using tags, marking, or stenciling) such that the identification:

- a. Does not adversely affect or damage the component for its function.
- b. Is clearly traceable to the proper individual component.
- c. Requires manual separation from the component/container.

In addition, all procured and removed components shall be identified with the following statement:

**NOTE**

"Upon receipt of this component, or for its disposition, please contact the SMMS PMT or NAVSEA 92T31. Do not dispose of this component unless directed otherwise by NAVSEA 92T31."

561-I.2.5 Ordering Requirements. Self-lubricated bearing replacement components shall be ordered directly from the manufacturers identified above, listed in the CID, or as otherwise approved by NAVSEA 92T. Ordering information shall include the necessary component identification information as specified above and any additional component ordering information as specified in the detailed installation requirements.

- a. In general, self-lubricated bearings are fabricated on a mandril in 10 to 24 inch lengths. In most cases, unit bearing costs are significantly reduced by purchasing the material in tube form, and sawing individual bearings to the required length on site.
- b. Specify the location of the wear surface (for example, on the ID for bushings or spherical bearing rings) and the minimum and maximum thickness of any wear liner.
- c. Ultrahigh molecular weight polyethylene (UHMWPE) is a non-proprietary material and may be obtained from a local plastics distributor. Also, most naval repair activities use UHMWPE in a variety of other applications, and have established local stocking procedures.
- d. When ordering materials, allow appropriate lead time. The lead time for most non-metallic materials except UHMWPE is approximately 4 to 6 weeks.
- e. For K-Monel parts, sleeves shall be made from ring forgings or centrifugal castings; welded plate is not permitted. The lead time will vary with the form required. Stock materials (e.g., bar, plate) may be readily available, but ring forgings may require up to 8 weeks. Always allow some time for final machining of the bearing parts.

561-I.2.6 Allowance For Final Machining. Both self-lubricated and metal bearing parts shall be ordered oversized to provide some allowance for final machining to fit the as-found or as-repaired stock OD and housing ID dimensions. Unless otherwise specified on the drawings, use allowances as follows:

- a. Connecting rod, tiller arm, and wrist pin bushings should be ordered with 1/8 inch margin on the OD.
- b. Connecting rod thrust washers may require up to 1/8 inch additional thickness over drawing requirements.
- c. Sleeves for main stock bearings should be ordered with 1/32 inch margin on the ID to account for stock OD variation.
- d. Bushings for main stock bearings should be ordered with 1/8 inch margin on the OD to account for housing or post ID variation.

561-I.2.7 Reuse of Existing Parts. The self-lubricated bearing repairs described in this document typically require replacement of the bearing (or bushing) and its mating bearing component, such as the stock sleeve. In some bearing applications, other non-wearing bearing components, such as the bearing carrier, housing, or retainer, are also specified for replacement with alternative materials. These non-wearing bearing components may be reused with NAVSEA 92T approval when the components are:

- (1) found to be in satisfactory material condition,
- (2) dimensionally compatible with interfacing parts, and
- (3) of a material that is compatible with interfacing parts.

561-I.2.8 Fabrication Requirements. The fabrication and assembly of replacement bearing components must:

- a. Restore bearing component clearances to the revised design tolerances with emphasis on achieving the minimum design clearance values. To achieve this requirement, new bearing parts should be fabricated to the maximum material condition allowed on the drawings. This will maximize interference fits and minimize clearances.
- b. Be sized to fit within the as-found or as-repaired dimensions of the major mating components, particularly the stock and bearing housings or posts. To achieve this requirement, measurements must be made of the stock OD, bearing housing or post ID, bushing bore ID, and/or guide cylinder ID following any repairs to these components. The mating bearing parts must then be final machined to provide the proper fit with the as-repaired components.
- c. Provide a finish on all metal bearing surfaces of 16 to 32  $\mu\text{in rms}$ . Surfaces shall be machined to 64  $\mu\text{in rms}$  or better and polished to 16 to 32  $\mu\text{in rms}$  to remove all residual machining edges.
- d. Provide a radius on all metal edges that can potentially contact self-lubricated bearing parts, such as bearing sleeves, spherical bearing loader slots and carrier bearing collar retaining pin holes.
- e. Exclude or remove all grease grooves and holes from applicable replacement bearing components. All applicable bearing grease connections, fittings, and flex hoses shall be removed and plugged.
- f. Keep provisions for o-rings or other seals to provide a means for excluding dirt from the bearing surface. Always install new software at assembly.
- g. Provide positive mechanical retention of the self-lubricated bearing parts. Retainer rings or plates should be used where possible to mechanically lock or encapsulate the bearing part so that it cannot "walk" out of position. Adhesives may also be used to bond self-lubricated bearing parts in place.

561-I.2.9 Self-lubricated Material Machining. Guidance for machining of self-lubricated materials is provided in [paragraphs 561-I.10](#) through [561-I.10.5](#).

561-I.2.10 Shop Practices. Typical shop practices required for installation of the self-lubricated bearing repairs described in this document include freeze fitting, lifting heavy components, torquing fasteners, painting, and others. Detailed procedures for these practices are not provided in this procedure. Approved local shop or shipyard procedures should be used.

561-I.2.11 Assembly Precautions. While self-lubricated bearing materials are less sensitive to installation variations than Stellite components, care must be taken not to damage the bearing wear surface. The following precautions shall be taken when assembling the bearings:

- a. During machining, take care not to let metal machining filings contact self-lubricated components.
- b. Clean surfaces of metal bearing components that contact self-lubricated bearing parts.
- c. Protect bearing wear surfaces with a soft rubber sheet after final machining.
- d. When lifting heavy parts that include pre-assembled self-lubricated bearings (e.g., connecting rods), do not lift or support the assembly with a chain or rope through the bearing bore. Use a strap around the outside of the assembly.
- e. Verify proper fit up and alignment of bearing components prior to freezing, heating, and/or pressing into place.
- f. When freeze fitting parts, dry ice (at  $-110^{\circ}\text{F}$ ) generally provides adequate cooling, however liquid nitrogen (at  $-320^{\circ}\text{F}$ ) may also be used. Use appropriate cryogenic liquid handling procedures when using liquid nitrogen.
- g. When installing press or shrink fit parts, use a tight fitting arbor to apply even pressure all around the edge of the bearing part. Do not use a hammer to force the part into place.
- h. When assembling the stock and bearing, coat bearing wear surfaces (for example, sleeve OD and bushing ID) with Termalene II grease, silicone or teflon spray to ease installation. Where possible, use temporary tapered wood or plastic guides taped to the stock to maintain concentricity of the stock and bearing and prevent binding.



561-I.2.12 As-installed Bearing Measurements. The self-lubricated bearing repairs described in this procedure typically require measuring the dimensions of bearings and mating parts to ensure proper fit up. Following installation, the as-installed bearing ID and stock sleeve or pin OD (or bearing clearance) should be measured and recorded. These measurements should be forwarded to NAVSEA 92T for use in trending bearing wear over time.

561-I.2.13 Threaded Fasteners. Always torque threaded fasteners to the specified value. Unless otherwise specified, use anaerobic thread locking compound (e.g., Mil-S-22473, Grade C) on all threaded fasteners at final assembly.

561-I.2.14 Removed Material. Unless otherwise specified by NAVSEA 92T31, damaged materials removed from the submarine shall be discarded. All undamaged removed material shall be turned in to the nearest Naval Property Manager and tagged with all identifying information.

561-I.2.15 Operating Gear Alignment. To prevent overload and accelerated wear of bearing components, every effort must be made to ensure the operating gear is properly aligned at final assembly. Proper alignment, as illustrated in [figure 561-I-3](#), requires that the thickness of keeper rings and thrust washers be sized to maintain the centerline of the operating rod, connecting rod, and tiller arms. Improper alignment causes side loads on the guide piston and thrust washers and uneven loading on the bearings.

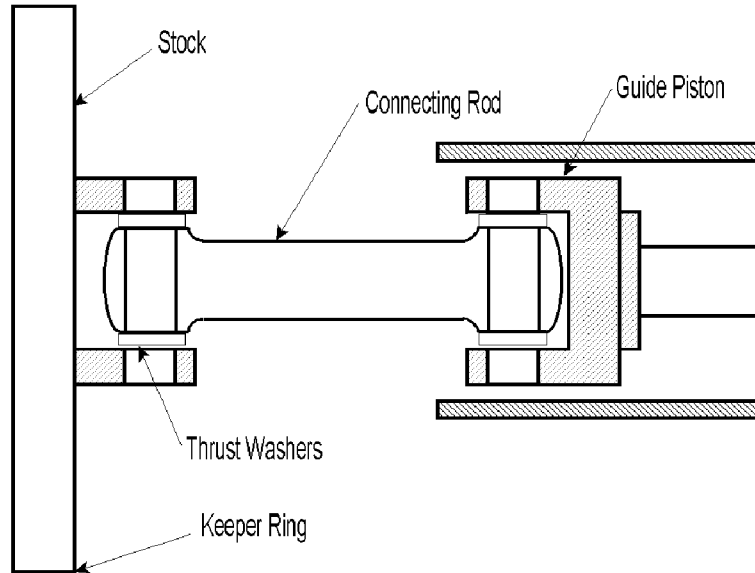

**Proper Operating Gear Alignment**

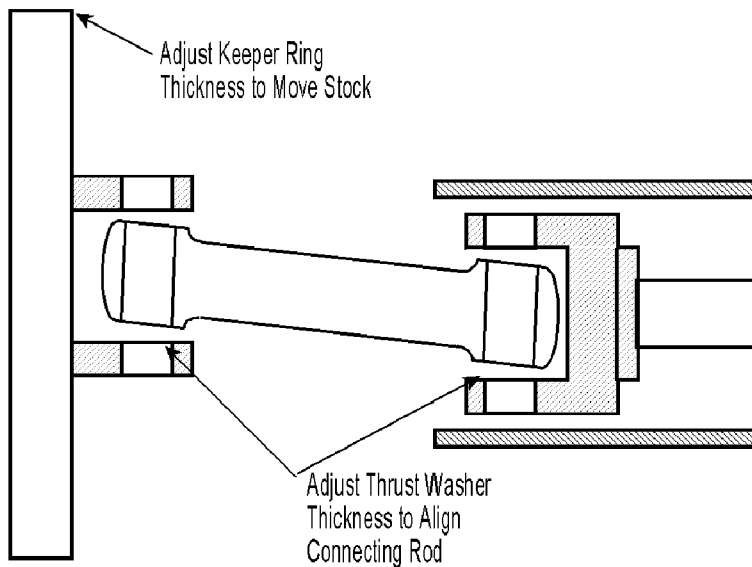

**Improper Operating Gear Alignment**

Figure 561-I-3 Operating Gear Alignment

561-I.2.16 Quality Assurance. Quality assurance, inspection and documentation required for these repairs are the responsibility of the facility performing installation and/or manufacturing. Required procedures will be carried out and documented in accordance with COMSUBPACINST 4355.4B, Sect 8 and 3 and approved established local practice.

561-I.2.16.1 Standard NAVSEA requirements in accordance with NAVSHIPS 0900-006-9010 and NAVSHIPS 0900-027-7010 shall apply as noted on referenced drawings.

561-I.2.16.2 Following completion of repairs, operate the affected steering or diving system in normal and emergency mode and check for smooth and quiet operation. Inspect operating gear and bearings for proper clearances and alignment.

**NOTE**

When measuring connecting rod freeplay, rotating the control surface into the hard stops and applying full hydraulic system pressure may compress the bearing material. This will yield false (excessive) clearance measurements.

561-I.2.16.3 Any abnormal operation or indications identified shall be reported directly to NAVSEA 92T31 (or PMT) for resolution. In all cases, provide bearing diametral and thrust measurement data and results of inspections to SMMS PMT.

**561-I.3 CONNECTING ROD BEARING REPAIR.**

561-I.3.1 Purpose And Scope. The following paragraphs provide detailed requirements for installation of the following SSN 688 and SSBN 726 Class submarine connecting rod bearing component repairs. The affected connecting rod bearing components are illustrated in [Figure 561-I-4](#).

## 561-I.3.1.1 SSN 688 Class.

1. Substituting self-lubricated connecting rod (tiller end) and tiller arm bushings for existing Nickel-Aluminum-Bronze (NiAlBrz, MIL-B-24059) bushings.
2. Substituting Ultra High Molecular Weight Polyethylene (ASTM D-4020) thrust washers for existing Naval Brass (Alloy 464, QQ-B-639) thrust washers.
3. If the guide piston is being modified per Chapter 4:
  - a. Installing new self-lubricated connecting rod (piston end) and guide piston bore (wrist pin) bushings.
  - b. Installing Ultra High Molecular Weight Polyethylene (ASTM D-4020) guide piston pin (wrist pin) end caps.
  - c. Substituting Ultra High Molecular Weight Polyethylene (ASTM D-4020) thrust washers for existing Naval Brass (Alloy 464, QQ-B-639) thrust washers.

## 561-I.3.1.2 SSBN 726 Class.

1. Substituting self-lubricated connecting rod (tiller end) bushings for existing Stellite Alloy 20 (MIL-C-15345) bushings.
2. Substituting self-lubricated tiller arm bushings for existing Nickel-Aluminum-Bronze (NiAlBrz, MIL-B-24480) bushings.
3. Substituting Ultra High Molecular Weight Polyethylene (ASTM D-4020) thrust washers for existing Gun Metal (Bronze, QQ-C-390) thrust washers.
4. Eliminating existing Stellite (Alloy 21) tiller and guide piston pin sleeves.
5. If the guide piston is being modified per [paragraphs 561-I.4](#) through [561-I.4.7](#):
  - a. Installing new self-lubricated connecting rod (piston end) and guide piston bore (wrist pin) bushings.
  - b. Substituting Ultra High Molecular Weight Polyethylene (ASTM D-4020) thrust washers for existing Naval Brass (Alloy 464, QQ-B-639) thrust washers.

These replacements will eliminate greasing requirements, reduce noise, reduce wear on the bushings, provide insulation from galvanic corrosion and extend the period between replacement of these parts.

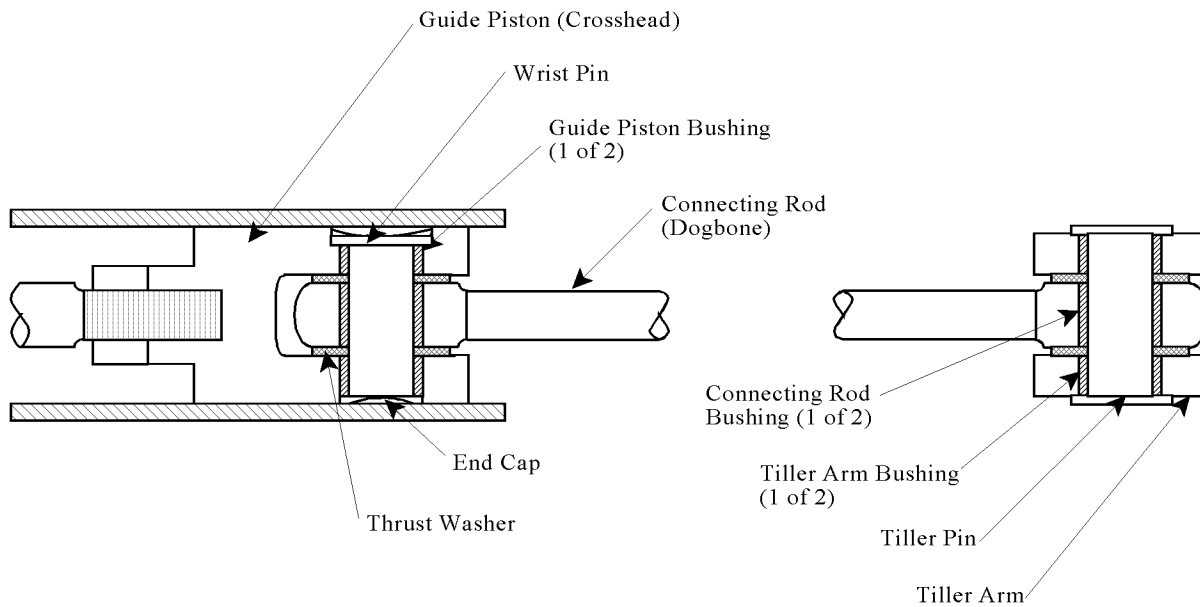

Figure 561-I-4 Typical Connecting Rod Bearing Repairs

561-I.3.2 Repair Requirements. The metallic bushings and thrust washers installed in SSN 688 and SSBN 726 Class submarine connecting rod bearing assemblies shall be replaced with self-lubricated, extended wear parts as illustrated in [Figure 561-I-4](#). The detailed parts are listed in [Tables 561-I-5](#) and [561-I-6](#), and are shown on drawings, [References 561-I.3.5.1](#) and [561-I.3.5.2](#).

561-I.3.2.1 For SSBN 726 Class submarines, the metallic tiller and guide piston pin sleeves will be deleted and heavy wall thickness bushings will be used.

561-I.3.2.2 For SSN 688 class submarines, if the guide piston is being modified per [paragraph 561-I.4](#) through [561-I.4.3.16](#) of this procedure, the wrist pin bores shall be modified to allow installation of self-lubricated bushings. The SSN 688 Class guide piston pin retaining assembly shall be modified to accommodate the bore bushings including the use of non-metallic (UHMWPE) pin end caps.

561-I.3.2.3 All general requirements specified in [paragraphs 561-I.2](#) through [561-I.2.16.3](#) of this procedure shall be met when performing the connecting rod bearing repairs.

561-I.3.2.4 Criteria to initiate these repairs during overhaul shall be MS's 5560-081-033, 5560-081-037, or 5560-081-038 (latest rev.) for SSN 688 Class or 5560-081-005, 5560-081-008, or 5560-081-009 (latest rev.) for SSBN 726 Class.

561-I.3.2.5 Criteria to initiate these repairs during a ship's operating cycle shall be based primarily on noise. As long as the components are not generating detectable noise and the system is operationally quiet, the repairs will not be initiated.

561-I.3.2.6 The clearance limits following repair shall be as specified on the drawings, [References 561-I.3.5.1](#) and [561-I.3.5.2](#).

561-I.3.3 Detailed Installation Requirements . The following actions are required to accomplish this repair:

**NOTE**

The connecting rod must be disassembled and removed in order to install these bearing modifications and repairs.

- a) Lock planes in position to allow safe removal of the connecting rod.
- b) Disassemble the connecting rod from the tiller and guide piston, as applicable. Disassembly from the piston involves disconnecting the operating rod at the coupling to allow removal of the connecting rod from the guide piston. Disassemble these components in accordance with NAVSEA drawings and established shipyard procedures.
- c) Remove the bushings from the tiller arms and the tiller and piston ends of the connecting rod, as applicable. Cut Stellite sleeves off of tiller pin and wrist pin, as applicable. Take care not to damage the OD surface of the pin.
- d) Disconnect the existing grease lines serving the connecting rod bearings on the tiller and guide piston ends, as applicable. Remove the flex hose tubing of the applicable grease lines between the bearing connections and the nearest terminal block. Remove the tube fittings from the bearing connection and plug the vacant orifices. Apply PR-380M thread sealant to plug threads prior to installation. Also plug the appropriate grease line terminal block/grease manifold ports and tube ends. Re-label greasing manifold accordingly.
- e) Inspect condition of connecting rod and tiller arm bores for acceptability per Maintenance Standards requirements. Clean all rust and corrosion from bore IDs and refurbish bores as necessary.

561-I.3.3.1 For SSN 688 Class submarines. If the guide piston is being modified per [paragraphs 561-I.4](#) through [561-I.4.7](#), accomplish the following:

- a) Machine guide piston bore to a larger diameter per Reference [561-I.3.5.1](#) to accommodate new bushings. Criteria for machining the bore shall be per Reference [561-I.3.5.1](#).
- b) Measure and record bores of connecting rod, tiller arm, and guide piston (as applicable) as shown on [Figure 561-I-5](#). Correct any out-of-round or bore misalignment problems found. If necessary, bore ID may be machined oversized by up to 0.120". If bores are machined, repeat measurements per [Figure 561-I-5](#).
- c) Measure and record tiller pin and wrist pin OD as shown on [Figure 561-I-6](#). Tiller pin and wrist pin ODs must be round within original drawing tolerances. If tiller pin or wrist pin are reused, refurbish surfaces to provide surface finish of 32  $\mu$ m rms.
- d) Use the worksheet in [Figure 561-I-7](#) to determine fit-up and final OD for each bushing. Refer to drawings, References [561-I.3.5.1](#) and [561-I.3.5.2](#), to determine the required bushing press fit. For SSN 688 Class submarines, see [Table 561-I-7](#) or [Table 561-I-8](#) as applicable.
- e) Final machine bushings per worksheet and drawings, References [561-I.3.5.1](#) and [561-I.3.5.2](#). Follow guidance in [paragraph 561-I.10](#) of this procedure for machining self-lubricated materials. Tag each bushing and indicate the location where the bushing is to be installed (for example, "connecting rod - tiller end").

**NOTE**

Do not machine grease holes and grease grooves in replacement bearing components.

- f) Fabricate thrust washers and wrist pin end caps. End caps may be made with a spherical surface on the end instead of a cylindrical surface.
- g) Machine 1/16" x 45° chamfers on the connecting rod, tiller and guide piston bore IDs and pin ODs if a chamfer does not already exist.
- h) Prepare tiller arm, connecting rod, and guide piston bores by roughing with 50-60 grit sandpaper. Clean tiller and guide piston pins and connecting rod and tiller bores until free of grease and debris.
- i) Cool the bushings using dry ice or liquid nitrogen or heat the tiller arms/ piston/connecting rod bore to 250°F (using inductive coils or heating blankets) to allow installation at room temperature. Alternatively use both cooling of the bushing and heating of the bore material to obtain a  $\Delta T$  of 170°F for installation of proper press fit.
- j) Press each bushing into the corresponding bore using even pressure all around the edge of the bushing. Use a tight fitting arbor to ease installation of the bushings.
- k) Measure and record and thrust clearances between the connecting rod and guide piston, and between the connecting rod

and tiller arms. Size each thrust washer thickness to align centerline of connecting rod with centerline of guide piston and center of tiller arms. Final machine thrust washer thickness per drawings, References 561-I.3.5.1 and 561-I.3.5.2.

As described in paragraph 561-I.2.15, proper alignment of the operating gear linkage is critical to overall performance of the system. Improper alignment will result in noise and accelerated bearing wear.

**NOTE**

If necessary, thrust washers may be made up of two UHMWPE pieces (i.e., UHMWPE thrust washer shims are acceptable). The minimum thickness for UHMWPE thrust washer shims shall be 0.125 inch.

- l) Reassemble connecting rod components in accordance with the applicable NAVSEA drawings and established procedures. Use care not to damage bushing ID surfaces.

**NOTE**

When reassembling connecting rod, do not lift or support connecting rod with a chain or rope through the bushing bores. Use straps around the outside of the connecting rod.

561-I.3.4 Prior And/Or Concurrent Alterations. The following prior ship alterations (shipalts) are applicable. The installation details are based on prior completion of these shipalts:

561-I.3.4.1 SSN 688 Class.

- a) SSN 688-2934 (3554) - - Modifies the connecting rod/tiller arm pin bearing and the connecting rod/guide piston pin bearings to provide remote greasing to these bearings.
- b) SSN 688-3328 - - Modifies thrust washer clearances to prevent stern and fairwater connecting rods from making hard contact with the thrust washers with the planes in the extreme (hard over) positions.

561-I.3.4.2 SSBN 726 Class. None identified.

561-I.3.5 References.

561-I.3.5.1 MPR Drawing 1059-126-10. "SSN 688 Class, Connecting Rod Bearing Component Replacement."

561-I.3.5.2 NAVSEA Drawing 7006698. "SSBN Trident Class, Steering and Diving Gear Connecting Rod Bearing Modification."

561-I.3.5.3 NAVSEA Drawing 4403809. "SSN 688 Class Submarine, Rudder Stocks, Posts & Yoke."

561-I.3.5.4 NAVSEA Drawing 6225162. "SSN 688 Class Submarine, Rudder Stocks, Posts & Yoke."

561-I.3.5.5 NAVSEA Drawing 4403812. "SSN 688 Class Submarine, Fairwater Diving Planes Stock & Bearings."

561-I.3.5.6 NAVSEA Drawing 4403816. "SSN 688 Class Submarine, Stern Diving Plane Stocks, Pintles, Bearings & Yoke."

561-I.3.5.7 NAVSEA Drawing 4457075. "SSN 688 Class Submarine, Steering Gear Aft Operating Gear Assembly."

- 561-I.3.5.8 NAVSEA Drawing 4457076. "SSN 688 Class Submarine, Steering Gear Crosshead & Oper. Rod Detail."
- 561-I.3.5.9 NAVSEA Drawing 4457079. "SSN 688 Class Submarine, Stern Diving Gear Aft Operating Gear Assembly."
- 561-I.3.5.10 NAVSEA Drawing 4457080. "SSN 688 Class Submarine, Stern Diving Gear Crosshead Guide & Operating Rod Details."
- 561-I.3.5.11 NAVSEA Drawing 4457125. "SSN 688 Class Submarine, Fairwater Diving Gear Aft Operating Gear Assembly."
- 561-I.3.5.12 NAVSEA Drawing 4457126. "SSN 688 Class Submarine, Fairwater Diving Gear Crosshead Guide Details."
- 561-I.3.5.13 NAVSEA Drawing 4643331. "SSBN Trident Class, Rudder Stock, Yoke & Details."
- 561-I.3.5.14 NAVSEA Drawing 4643344. "SSBN Trident Class, Stern Plane Stock, Yoke, Bearing & Post."
- 561-I.3.5.15 NAVSEA Drawing 4643402. "SSBN Trident Class, Fairwater Diving Planes Stock and Details."
- 561-I.3.5.16 NAVSEA Drawing 4674747. "SSBN Trident Class, Steering Gear Assembly and Installation."
- 561-I.3.5.17 NAVSEA Drawing 4674753. "SSBN Trident Class, Steering/Diving Gear Connecting Rod & Details."
- 561-I.3.5.18 NAVSEA Drawing 4674761. "SSBN Trident Class, Stern Diving Gear Assembly and Installation."
- 561-I.3.5.19 NAVSEA Drawing 4674799. "SSBN Trident Class, Fairwater Diving Gear Assembly and Installation."
- 561-I.3.5.20 NAVSEA Drawing 4674802. "SSBN Trident Class, Fairwater Diving Gear Crosshead Misc."
- 561-I.3.5.21 Maintenance Standard (MS) 5560-081-005. "Overhaul Fairwater Diving Gear."
- 561-I.3.5.22 Maintenance Standard (MS) 5560-081-006. "Overhaul Stern Diving Gear Operation Linkage."
- 561-I.3.5.23 Maintenance Standard (MS) 5560-081-007. "Overhaul Steering Gear Operation Linkage."
- 561-I.3.5.24 Maintenance Standard (MS) 5560-081-008. "Overhaul Stern Diving Gear (Drydocking Required)."
- 561-I.3.5.25 Maintenance Standard (MS) 5560-081-009. "Overhaul Steering Gear (Drydocking Required)."
- 561-I.3.5.26 Maintenance Standard (MS) 5560-081-033. "Restore External Parts of Steering Gear."
- 561-I.3.5.27 Maintenance Standard (MS) 5560-081-037. "Restore Fairwater Diving Gear."
- 561-I.3.5.28 Maintenance Standard (MS) 5560-081-038. "Restore External Parts of Stern Diving Gear."

- 561-I.3.5.29 General Dynamics, EBDiv Drawing 41052-566000. "Rudder Tiller Pin Replacement Procedure."
- 561-I.3.5.30 General Dynamics, EBDiv Drawing 41053-566000. "Rudder Crosshead Pin Replacement Procedure."
- 561-I.3.5.31 General Dynamics, EBDiv Drawing 41054-566000. "Rudder Connecting Rod Replacement Procedure."
- 561-I.3.5.32 General Dynamics, EBDiv Drawing 41032-566000. "Stern Plane Tiller Pin Replacement Procedure."
- 561-I.3.5.33 General Dynamics, EBDiv Drawing 41058-566000. "Stern Plane Crosshead Pin Replacement Procedure."
- 561-I.3.5.34 General Dynamics, EBDiv Drawing 41049-566000. "Stern Plane Connecting Rod Replacement Procedure."
- 561-I.3.5.35 General Dynamics, EBDiv Drawing 41034-566000. "Fairwater Plane Crosshead and Bearing Replacement Procedure."
- 561-I.3.5.36 DTRC 9073 Code 2744POP. David Taylor Research Center "Temporary Alteration Technical Data Package: Fairwater Diving Planes Bearings, SSBN 726 Class Submarines", including DTRC drawing A27-20023-1 through A27-20023-5.

561-I.3.6 Maintenance Requirement Parts List. Refer to [Tables 561-I-5](#) and [561-I-6](#), and drawings, References [561-I.3.5.1](#) and [561-I.3.5.2](#) for materials required to accomplish these repairs for the applicable submarine class.

**NOTE**

The ordering dimensions specified in the referenced drawing include allowance for field machining components to the final dimensions. Field machining is done after as-built measurements are performed.

561-I.3.6.1 The tiller arm, connecting rod, and guide piston bushings may be ordered in tubes of the manufacturer's standard lengths and cut to size per the reference drawings. In some cases, this may reduce the overall cost of the self-lubricated bearing material. The table below shows the required materials for both 10" and 24" standard tube lengths.

Required Bushing Material in Standard Tube Lengths

Control Surface	Rough Bushing OD	Nominal Bushing ID	10" Lengths Qty Req'd	24" Lengths Qty Req'd
SSN 688 Class Stern Diving	4.625	4.00	3	1
SSN 688 Class Steering	5.375	4.75	3	1
SSN 688 Class Fairwater	5.625	5.00	3	1
SSBN 726 Class Steering & Stern Diving	7.375	5.75	4	2
SSBN 726 Class Fairwater	8.625	6.50	4	2

**NOTE**

Quantity shown is number of lengths required for one complete submarine linkage (connecting rod, tiller arm, and piston bushings)



561-I.3.7 Final Inspection. Perform and record connecting rod bearing diametral and thrust clearance measurements in accordance with Maintenance Standards or ship drawings as applicable.

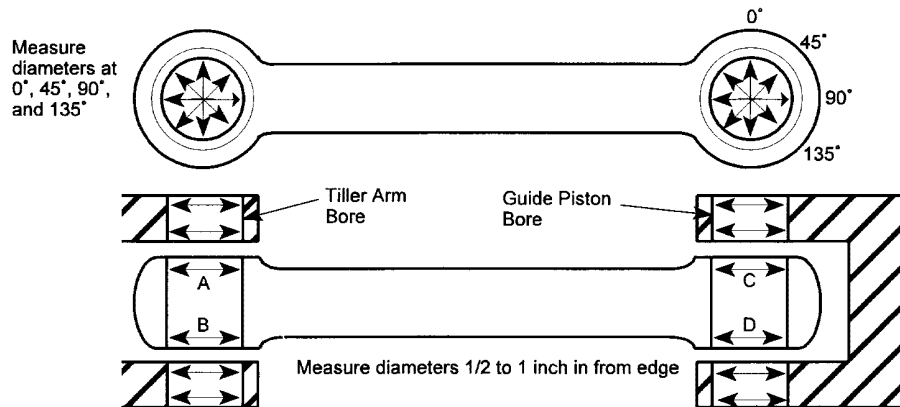

Connecting Rod Bore ID Measurements				
0°				
45°				
90°				
135°				
Average				

A B C D

Tiller Arm Bore ID Measurements				
0°				
45°				
90°				
135°				
Average				

A B C D

Guide Piston Bore ID Measurements				
0°				
45°				
90°				
135°				
Average				

Figure 561-I-5 Bushing Measurement Worksheet

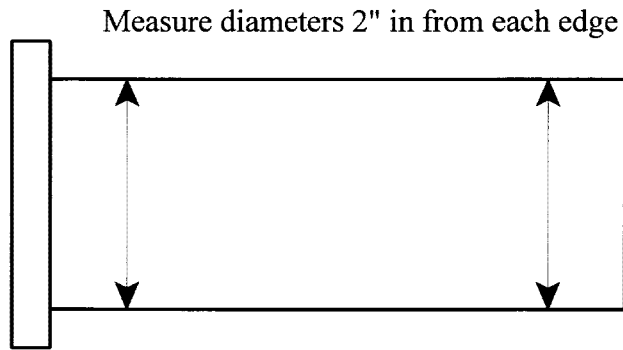

Measure diameters at 0°, 45°, 90°, and 135°

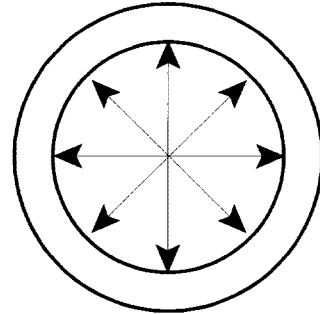

Tiller Pin OD Measurements		
0°		
45°		
90°		
135°		
Average		

Wrist Pin OD Measurements		
0°		
45°		
90°		
135°		
Average		

Figure 561-I-6 Pin Measurement Worksheet

The following steps describe the method for determining the final machining requirements for each bushing OD.

Dimension <sup>(1)</sup>

1. Measure bushing ID in four places 45° apart. Record average: \_\_\_\_\_ <sup>(2)</sup>
2. Enter bushing press fit (maximum): \_\_\_\_\_
3. Subtract line 2 from 1 = expected bushing ID after installation: \_\_\_\_\_
4. Measure the pin OD per Figure 561-I-5. Record average: \_\_\_\_\_ <sup>(2, 3)</sup>
5. Subtract line 4 from 3 = expected bearing clearance:
6. Compare the expected bearing clearance (line 5) to the required clearance at final assembly as specified in drawing or Table 561-I-7 or 561-I-8, as applicable. If OK, go to step 7. If the line 5 value is not within the required final clearance range, adjust required bushing press fit as follows:
 

If line 5 value is less than minimum required clearance:

  - a. Subtract line 5 from minimum required clearance = \_\_\_\_\_
  - b. Adjusted bushing press fit = line 2 **minus** line 6a = \_\_\_\_\_

If line 5 value is greater than maximum required clearance:

  - c. Subtract maximum required clearance from line 5 = \_\_\_\_\_
  - d. Adjusted bushing press fit = line 2 **plus** line 6c = \_\_\_\_\_
7. Measure housing bore ID per Figure 561-I-4. Record average: \_\_\_\_\_ <sup>(3)</sup>
8. Enter required bushing press fit from either line 2, line 6b or line 6d:
9. Bushing OD = bore ID (line 7) plus required bushing press fit (line 8):

NOTES:

- <sup>(1)</sup> Measure all dimensions to within 0.001".
- <sup>(2)</sup> Where referenced to this note, the component dimensions should be within the applicable design dimensions specified in References 561-I.3.5.1 and 561-I.3.5.2.
- <sup>(3)</sup> Pin OD and bore ID shall be round, or machined round, to within ±0.001".

Figure 561-I-7 Final Bushing OD Machining Worksheet

**Table 561-I-5** Summary of SSN 688 Class Connecting Rod Bearing Material Replacements

Control Surface	Qty	Component Applicable Dwg/Pc.#	Materials		Nominal Size OD x ID x lg (inch)
			Existing	Replacement	
Fairwater Diving	2	Connecting Rod Bushing 4457126/Pc 6	Ni-Al-Brz Mil-B-24059	Self-Lubricated Bearing CID A-A-50602	5.625 x 5.00 x 5.490 lg
	2	Tiller Arm Bushing 4403812/Pc 24	Ni-Al-Brz Mil-B-24059	Self-Lubricated Bearing CID A-A-50602	5.625 x 5.00 x 2.344 lg
	2	Guide Piston Bore Bushing (new)	(N/A)	Self-Lubricated Bearing CID A-A-50602	5.625 x 5.00 x 2.375 lg
	2	Thrust Washer (Tiller End) 4457126/Pc 3	Naval Brass Alloy 464, QQ-B-639	UHMWPE ASTM D-4020	6.50 x 5.063 x 0.115 thk
	2	Thrust Washer (Piston End) 4457126/Pc 6	Naval Brass Alloy 464, QQ-B-639	UHMWPE ASTM D-4020	6.50 x 5.063 x 0.115 thk
	1	Wrist Pin End Cap	(N/A)	UHMWPE ASTM D-4020	5.495 x 0.730 thk
	1	Wrist Pin End Cap	(N/A)	UHMWPE ASTM D-4020	5.495 x 0.960 thk
Stern Diving	2	Connecting Rod Bushing 4457080/Pc 1 or 25	Ni-Al-Brz Mil-B-24059	Self-Lubricated Bearing CID A-A-50602	4.625 x 4.00 x 4.990 lg
	2	Tiller Arm Bushing 4403816/Pc 54	Ni-Al-Brz Alloy 630, QQ-C-465	Self-Lubricated Bearing CID A-A-50602	4.625 x 4.00 x 3.500 lg
	2	Guide Piston Bore Bushing (new)	(N/A)	Self-Lubricated Bearing CID A-A-50602	4.625 x 4.00 x 2.625 lg
	2	Thrust Washer (Tiller End) 4457080/Pc 18	Naval Brass Alloy 464, QQ-B-639	UHMWPE ASTM D-4020	8.00 x 4.031 x 0.625 thk
	2	Thrust Washer (Piston End) 4457080/Pc 2	Naval Brass Alloy 464, QQ-B-639	UHMWPE ASTM D-4020	8.00 x 4.031 x 0.250 thk
	1	Wrist Pin End Cap	(N/A)	UHMWPE ASTM D-4020	4.495 x 0.700 thk
	1	Wrist Pin End Cap	(N/A)	UHMWPE ASTM D-4020	4.495 x 0.945 thk
Rudder	2	Connecting Rod Bushing 4457076/Pc 1 or 25	Ni-Al-Brz Mil-B-24059	Self-Lubricated Bearing CID A-A-50602	5.375 x 4.75 x 4.990 lg
	2	Tiller Arm Bushing 4637646/Pc 29	Ni-Al-Brz Mil-B-24059	Self-Lubricated Bearing CID A-A-50602	5.375 x 4.75 x 3.500 lg
	2	Guide Piston Bore Bushing (new)	(N/A)	Self-Lubricated Bearing CID A-A-50602	5.375 x 4.75 x 2.625 lg
	2	Thrust Washer (Tiller End) 4457076/Pc 18	Naval Brass Alloy 464, QQ-B-639	UHMWPE ASTM D-4020	8.00 x 4.781 x 0.625 thk
	2	Thrust Washer (Piston End) 4457076/Pc 2	Naval Brass Alloy 464, QQ-B-639	UHMWPE ASTM D-4020	8.00 x 4.781 x 0.250 thk

**Table 561-I-5** Summary of SSN 688 Class Connecting Rod Bearing Material

## Replacements - Continued

Control Surface	Qty	Component Applicable Dwg/Pc.#	Materials		Nominal Size OD x ID x lg (inch)
			Existing	Replacement	
	1	Wrist Pin End Cap	(N/A)	UHMWPE ASTM D-4020	5.245 x 0.700 thk
	1	Wrist Pin End Cap	(N/A)	UHMWPE ASTM D-4020	5.245 x 0.945 thk

**Table 561-I-6** Summary of SSBN 726 Class Connecting Rod Bearing Material

## Replacements

Control Surface	Qty	Component Applicable Dwg/Pc #	Materials		Nominal Size OD x ID x lg (inch)
			Existing	Replacement	
Fairwater Diving	2	Connecting Rod Bush- ing 4674802/Pc 7	Stellite Alloy 20, Mil-C-15345	Self-Lubricated Bearing CID A-A- 50602	8.625 x 6.50 x 7.485 lg
	2	Tiller Arm Bushing 4643402/Pc 8	Ni-Al-Brz Mil-B- 24480	Self-Lubricated Bearing CID A-A- 50602	8.625 x 6.50 x 3.485 lg
	2	Guide Piston Bore Bushing 4674802/Pc 15	Stellite Alloy 20, Mil-C-15345	Self-Lubricated Bearing CID A-A- 50602	8.625 x 6.50 x 5.485 lg
	2	Thrust Washer (Tiller End) 4674802/Pc 17	Bronze (Gun Metal) Alloy 903, QQ-C- 390	UHMWPE ASTM D-4020	12.00 x 6.530 x 0.620 thk
	2	Thrust Washer (Piston End) 4674802/Pc 11	Bronze (Gun Metal) Alloy 05 Ty1 QQ-C-390	UHMWPE ASTM D-4020	12.00 x 6.530 x 0.480 thk
	2	Tiller Pin Sleeve 4674802/Pc 5	Stellite Alloy 21, Mil-C-15345	(Removed)	N/A
	2	Piston (Crosshead) Pin Sleeve 4674802/Pc 6	Stellite Alloy 21, Mil-C-15345	(Removed)	N/A
Stern Diving	2	Connecting Rod Bush- ing 4674753/Pc 8	Stellite Alloy 20, Mil-C-15345	Self-Lubricated Bearing CID A-A- 50602	7.375 x 5.75 x 7.715 lg
	2	Tiller Arm Bushing 4643344/Pc 19	Ni-Al-Brz Mil-B- 24480	Self-Lubricated Bearing CID A-A- 50602	7.125 x 5.75 x 3.965 lg
	1	Guide Piston Bore Bushing 4674753/Pc 11	Stellite Alloy 20, Mil-C-15345	Self-Lubricated Bearing CID A-A- 50602	7.375 x 5.75 x 3.105 lg
	1	Guide Piston Bore Bushing 4674753/Pc 12	Stellite Alloy 20, Mil-C-15345	Self-Lubricated Bearing CID A-A- 50602	7.375 x 5.750 x 4.105 lg
	2	Thrust Washer (Tiller End) 4674768/Pc 5	Bronze (Gun Metal) Alloy 05 Ty5 QQ-C-390	UHMWPE ASTM D-4020	11.875 x 5.785 x 0.50 thk

**Table 561-I-6** Summary of SSBN 726 Class Connecting Rod Bearing  
Material Replacements - Continued

Control Surface	Qty	Component Applicable Dwg/Pc #	Materials		Nominal Size OD x ID x lg (inch)
			Existing	Replacement	
	2	Thrust Washer (Piston End) 4674753/Pc 15	Bronze (Gun Metal) Alloy 05 Ty1 QQ-C-390	UHMWPE ASTM D-4020	11.875 x 5.785 x 0.50 thk
	2	Tiller Pin Sleeve 4674753/Pc 27	Stellite Alloy 21, Mil-C-15345	(Removed)	N/A
	2	Piston Pin Sleeve 4674753/Pc 10	Stellite Alloy 21, Mil-C-15345	(Removed)	N/A
Rudder	2	Connecting Rod Bushing 4674753/Pc 8	Stellite Alloy 20, Mil-C-15345	Self-Lubricated Bearing CID A-A-50602	7.375 x 5.75 x 7.715 lg
	2	Tiller Arm Bushing 4643331/Pc 17	Ni-Al-Brz Mil-B-24480	Self-Lubricated Bearing CID A-A-50602	7.375 x 5.75 x 3.965 lg
	1	Guide Piston Bore Bushing 4674753/Pc 11	Stellite Alloy 20, Mil-C-15345	Self-Lubricated Bearing CID A-A-50602	7.375 x 5.75 x 3.105 lg
	1	Guide Piston Bore Bushing 4674753/Pc 12	Stellite Alloy 20, Mil-C-15345	Self-Lubricated Bearing CID A-A-50602	7.375 x 5.750 x 4.105 lg
	2	Thrust Washer (Tiller End) 4674753/Pc 15	Bronze (Gun Metal) Alloy 05 Ty5 QQ-C-390	UHMWPE ASTM D-4020	11.875 x 5.785 x 0.50 thk
	2	Thrust Washer (Piston End) 4674753/Pc 15	Bronze (Gun Metal) Alloy 05 Ty1 QQ-C-390	UHMWPE ASTM D-4020	11.875 x 5.785 x 0.50 thk
	2	Tiller Pin Sleeve 4674753/Pc 9	Stellite Alloy 21, Mil-C-15345	(Removed)	N/A
	2	Piston Pin Sleeve 4674753/Pc 10	Stellite Alloy 21, Mil-C-15345	(Removed)	N/A

**Table 561-I-7** SSN 688 Class Submarines -- Standardized Tufite Bushing Sizes  
(inch)

Class and Control Surface	Nominal Housing Bore ID	Bushing ID (Catalog)	Press Fit	Assembled Bushing ID	Sleeve/Pin OD	Assembled Clearance
SSN 688 Stern Diving	4.50	4.012	0.005	4.011	4.000	0.013
		4.009	0.001	4.004	3.998	0.004
SSN 688 Steering	5.25	4.763	0.005	4.762	4.750	0.014
		4.760	0.001	4.755	4.748	0.005
SSN 688 Fairwater	5.50	5.013	0.005	5.012	5.001	0.013
		5.010	0.001	5.005	4.999	0.004

**Table 561-I-8** SSN 688 Class Submarines -- Standardized Orkot Bushing Sizes (inch)

Class and Control Surface	Nominal Housing Bore ID	Bushing ID	Press Fit	Assembled Bushing ID	Sleeve/Pin OD	Assembled Clearance
SSN 688 Stern Diving	4.50	4.027	0.019	4.012	4.000	0.014
		4.023	0.015	4.004	3.998	0.004
SSN 688 Steering	5.25	4.778	0.019	4.763	4.750	0.015
		4.774	0.015	4.755	4.748	0.005
SSN 688 Fairwater	5.50	5.028	0.019	5.013	5.001	0.014
		5.024	0.015	5.005	4.999	0.004

#### 561-I.4 GUIDE PISTON REPAIR.

561-I.4.1 Purpose And Scope. The following paragraphs provide detailed requirements for installation of SSN 688 and SSBN 726 Class submarine guide piston (crosshead) component repairs. The affected bearing components are illustrated in [Figure 561-I-8](#). These repairs include the following:

##### 561-I.4.1.1 SSN 688 Class:

- a. Modifying the existing Ni-Al-Brz guide piston to reduce the OD and provide dovetail slots for installation of Orkot TXM (or equivalent) non-metallic bearing staves.
- b. Plugging the guide piston vent holes to eliminate water flow impingement and reduce the resulting erosion/corrosion of the alloy steel connecting rod.
- c. Installing MIL-B-24480 Ni-Al-Brz threaded inserts to repair guide piston thread problems (such as dealloying of the MIL-B-21230 Ni-Al-Brz material). The Ni-Al-Brz material per MIL-B-24480 has mechanical properties similar to Ni-Al-Brz material per MIL-B-21230, but it has demonstrated an increased resistance to dealloying in the seawater environment.

##### 561-I.4.1.2 SSBN 726 Class:

- a. Modifying the existing Ni-Al-Brz guide pistons to reduce the OD and provide dovetail slots for installation of Orkot TXM, UHMWPE, or equivalent non-metallic bearing staves.
- b. Replacing the existing Delrin guide piston pin end caps with Ni-Al-Brz end caps.
- c. Installing threaded inserts as necessary to repair guide piston-to-operating rod thread problems.

In addition, when the guide piston is removed to accomplish these repairs, the connecting rod and tiller arm bushings shall be replaced in accordance with [paragraphs 561-I.3](#) through [561-I.3.7](#).

These replacements will eliminate greasing requirements, reduce noise, reduce wear on the guide piston and guide tube, provide insulation from galvanic corrosion and extend the period between replacement of these parts.

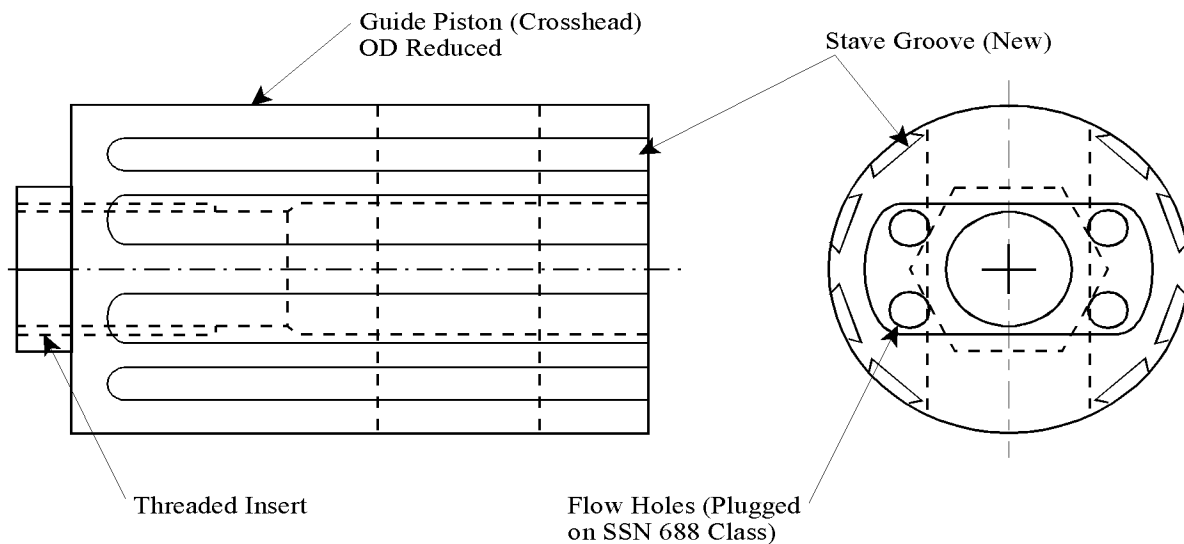

Figure 561-I-8 Typical Guide Piston Repairs

561-I.4.2 Repair Requirements. The SSN 688 and SSBN 726 Class submarine guide pistons shall be modified to permit installation of non-metallic bearing staves in accordance with drawings, References [561-I.4.5.1](#), [561-I.4.5.2](#), or [561-I.4.5.4](#). For SSN 688 Class submarines, the guide piston wrist pin bores shall also be modified to allow installation of self-lubricated bushings.

561-I.4.2.1 Installation of SSN 688 and SSBN 726 Class submarine self-lubricated guide piston bushings shall also be accomplished per [paragraphs 561-I.3](#) through [561-I.3.7](#) of this procedure.

561-I.4.2.2 All general requirements specified in [paragraphs 561-I.2](#) through [561-I.2.16.3](#) of this procedure shall be met when performing the guide piston modifications and repairs.

561-I.4.2.3 Criteria to initiate these repairs during overhaul shall be MS's 5560-081-033, 5560-081-037, or 5560-081-038 (latest rev.) for SSN 688 Class or 5560-081-005, 5560-081-008, or 5560-081-009 (latest rev.) for SSBN 726 Class.

561-I.4.2.4 Criteria to initiate these repairs during a ships' operating cycle shall be based primarily on noise. As long as the components are not generating detectable noise and the system is operationally quiet, the repairs will not be initiated.

561-I.4.2.5 The clearance limits following repair shall be as specified on the drawings, References [561-I.4.5.1](#), [561-I.4.5.2](#), or [561-I.4.5.4](#).

561-I.4.3 Detailed Installation Requirements. The following actions are required to accomplish this repair:

#### NOTE

The connecting rod and guide piston must be disassembled and removed in order to install these bearing modifications and repairs. The guide piston must be removed from the submarine to allow machining of the dovetail slots for the staves (and machining of the guide piston bores for SSN 688 Class submarines).

561-I.4.3.1 Disassemble the connecting rod from the tiller and guide piston in accordance with [paragraphs 561-I.3](#) through [561-I.3.7](#) of this procedure.



561-I.4.3.2 Disassemble the guide piston from the operating rod in accordance with NAVSEA drawings and established procedures.

561-I.4.3.3 Disconnect the existing grease lines serving the guide piston bearings. Remove the flex hose tubing of the applicable grease lines between the bearing connections and the nearest terminal block. Remove the tube fittings from the bearing connection and plug the vacant orifices. Apply PR-380M thread sealant to plug threads prior to installation. Also plug the appropriate grease line terminal block/grease manifold ports and tube ends. Re-label greasing manifold accordingly.

561-I.4.3.4 Remove scale and corrosion buildup from guide tube ID.

561-I.4.3.5 Inspect the guide piston bearing surfaces and operating rod threads for acceptability per Maintenance Standard requirements.

561-I.4.3.6 Measure and record the wrist pin bore ID, piston OD, and guide tube ID as required per the worksheet in [Figure 561-I-8](#). Use the worksheet to determine fit-up and final machining requirements.

561-I.4.3.7 For SSN 688 Class submarines, machine guide piston wrist pin bore to a larger diameter per [paragraphs 561-I.3 through 561-I.3.7](#) and drawing, Reference [561-I.3.5.1](#). Criteria for machining the bore shall be per the drawing, Reference [561-I.3.5.1](#).

561-I.4.3.8 Machine guide piston OD and stave slots to the final dimensions specified in accordance with the drawings, References [561-I.4.5.1](#), [561-I.4.5.2](#), or [561-I.4.5.4](#).

#### NOTE

Do not machine grease holes and grease grooves in replacement bearing components.

561-I.4.3.9 Determine final stave thickness requirements in accordance with the drawings, References [561-I.4.5.1](#), [561-I.4.5.2](#), or [561-I.4.5.4](#).

#### NOTE

The stave thickness can be adjusted to accommodate an out-of-round guide tube ID. For example, the four top and bottom staves can be made thicker than the four side staves if the guide tube ID in the vertical direction is larger than the ID in the horizontal direction.

561-I.4.3.10 Machine staves to final dimensions. Use the methods applicable to the form in which the non-metallic bearing material has been supplied:

- a. Flat plate - - Cut to length and machine dovetail angles on staves. Final thickness and outer radius is machined by installing staves in modified guide piston and turning on a lathe. Alternatively, a stave slot fixture can be fabricated from aluminum plate of appropriate thickness. Dovetail grooves are machined in the sides of the plate such that the grooves exactly match opposing pairs of grooves in the modified guide piston. The fixture is then turned on a lathe and staves are final machined two at a time.

#### NOTE

For stave materials with a wear surface on one side (e.g., Orkot TXM), care must be taken to avoid removing excessive material on the wear surface. Machine non-wear side first to obtain final thickness. Then machine wear side to obtain radius.

- b. Tube - - Tube OD must provide required stave outer radius. Cut tube lengthwise into the required number of sections. Install sections in a hold down fixture and machine inside (i.e., concave) surface flat, providing the required final stave thickness. Finally, machine dovetail angles and cut to final length.

Follow precautions and guidance in [paragraph 561-I.10](#) of this procedure for machining self-lubricated materials.

561-I.4.3.11 For SSN 688 Class submarines experiencing guide piston dealloying problems, machine out dealloyed operating rod threads and install Ni-Al-Brz (Mil-B-24480) thread inserts in accordance with drawing, Reference [561-I.4.5.1](#).

561-I.4.3.12 For all SSN 688 Class submarines, plug the four guide piston vent holes in accordance with drawing, Reference [561-I.4.5.1](#).

561-I.4.3.13 For SSBN 726 Class submarines with guide piston thread dealloying or other degradation, machine out operating rod threads and install thread insert in accordance with drawing, Reference [561-I.4.5.3](#).

561-I.4.3.14 Clean all surfaces of the guide tube ID and guide piston until free of grease, scale, and other debris. This includes guide piston bores, stave slots, and end caps.

561-I.4.3.15 Install staves in guide piston slots and secure with retainers per drawings, References [561-I.4.5.1](#), [561-I.4.5.2](#), or [561-I.4.5.4](#). Tighten retainer fasteners with the torques specified on these drawings.

561-I.4.3.16 Complete remaining connecting rod/guide piston assembly and installation (including installation of self-lubricated bushings) per [paragraphs 561-I.3](#) through [561-I.3.7](#) of this procedure.

561-I.4.4 Prior And/or Concurrent Alterations. The following prior ship alterations (shipalts) are applicable. The installation details are based on prior completion of these shipalts:

I.4.4.1 SSN 688 Class:

1. SSN 688-2934 (3554) - - Modifies the connecting rod/tiller arm pin bearing and the connecting rod/guide piston pin bearings to provide remote greasing to these bearings.
2. SSN 688-3328 - - Modifies thrust washer clearances to prevent stern and fairwater connecting rods from making hard contact with the thrust washers with the planes in the extreme (hard over) positions.

I.4.4.2 SSBN 726 Class: (None identified)

561-I.4.5 References.

561-I.4.5.1 MPR Drawing 1059-126-62. "SSN 688 Class, Guide Piston Assembly Modifications."

561-I.4.5.2 NAVSEA Drawing 7006697. "SSBN Trident Class, Steering and Diving Gear Guide Tube Bearing Modification."

561-I.4.5.3 NAVSEA Drawing 7006700. "SSBN Trident Class, Steering and Diving Gear Crosshead Thread Repair."

561-I.4.5.4 Puget Sound Naval Shipyard Drawing 5307865. "Fairwater Diving Gear Guide Piston Modification."

561-I.4.5.5 MPR Report, MPR-1090. "Design of Stave Bearings for the Steering Gear Guide Piston on SSBN TRIDENT Class Submarines," January 1989.

561-I.4.5.6 MPR Report, MPR-1746. "SSN 688 Class Submarine Steering and Diving Gear Guide Piston Modifications," July 1996.

561-I.4.5.7 NAVSEA Drawing 4457075. "SSN 688 Class Submarine, Steering Gear Aft Operating Gear Assembly."

- 561-I.4.5.8 NAVSEA Drawing 4457076. "SSN 688 Class Submarine, Steering Gear Crosshead & Oper. Rod Detail."
- 561-I.4.5.9 NAVSEA Drawing 4457079. "SSN 688 Class Submarine, Stern Diving Gear Aft Operating Gear Assembly."
- 561-I.4.5.10 NAVSEA Drawing 4457080. "SSN 688 Class Submarine, Stern Diving Gear Crosshead Guide & Operating Rod Details."
- 561-I.4.5.11 NAVSEA Drawing 4457125. "SSN 688 Class Submarine, Fairwater Diving Gear Aft Operating Gear Assembly."
- 561-I.4.5.12 NAVSEA Drawing 4457126. "SSN 688 Class Submarine, Fairwater Diving Gear Crosshead Guide Details."
- 561-I.4.5.13 NAVSEA Drawing 4674747. "SSBN Trident Class, Steering Gear Assembly and Installation."
- 561-I.4.5.14 NAVSEA Drawing 4674753. "SSBN Trident Class, Steering/Diving Gear Connecting Rod & Details."
- 561-I.4.5.15 NAVSEA Drawing 4674761. "SSBN Trident Class, Stern Diving Gear Assembly and Installation."
- 561-I.4.5.16 NAVSEA Drawing 4674799. "SSBN Trident Class, Fairwater Diving Gear Assembly and Installation."
- 561-I.4.5.17 NAVSEA Drawing 4674802. "SSBN Trident Class, Fairwater Diving Gear Crosshead Misc. Details."
- 561-I.4.5.18 Maintenance Standard (MS) 5560-081-005. "Overhaul Fairwater Diving Gear."
- 561-I.4.5.19 Maintenance Standard (MS) 5560-081-006. "Overhaul Stern Diving Gear Operation Linkage."
- 561-I.4.5.20 Maintenance Standard (MS) 5560-081-007. "Overhaul Steering Gear Operation Linkage."
- 561-I.4.5.21 Maintenance Standard (MS) 5560-081-008. "Overhaul Stern Diving Gear (Drydocking Required)."
- 561-I.4.5.22 Maintenance Standard (MS) 5560-081-009. "Overhaul Steering Gear (Drydocking Required)."
- 561-I.4.5.23 Maintenance Standard (MS) 5560-081-033. "Restore External Parts of Steering Gear."
- 561-I.4.5.24 Maintenance Standard (MS) 5560-081-037. "Restore Fairwater Diving Gear."
- 561-I.4.5.25 Maintenance Standard (MS) 5560-081-038. "Restore External Parts of Stern Diving Gear."
- 561-I.4.5.26 General Dynamics, EBDiv Drawing 41053-566000. "Rudder Crosshead Pin Replacement Procedure."
- 561-I.4.5.27 General Dynamics, EBDiv Drawing 41055-566000. "Rudder Crosshead Replacement Procedure."
- 561-I.4.5.28 General Dynamics, EBDiv Drawing 41058-566000. "Stern Plane Crosshead Pin Replacement Procedure."

561-I.4.5.29 General Dynamics, EBDiv Drawing 41050-566000. "Stern Plane Crosshead Replacement Procedure."

561-I.4.5.30 General Dynamics, EBDiv Drawing 41034-566000. "Fairwater Plane Crosshead and Bearing Replacement Procedure."

561-I.4.6 Maintenance Requirement Parts List. Refer to [Tables 561-I-9](#) and [Tables 561-I-10](#), and drawings, References [561-I.4.5.1](#), [561-I.4.5.2](#), or [561-I.4.5.4](#), for materials required to accomplish these repairs for the applicable submarine class.

**NOTE**

The ordering dimensions specified in the referenced drawing include allowance for field machining components to the final dimensions. Field machining is done after as-built measurements are performed.

561-I.4.7 Final Inspection. Perform connecting rod/operating rod alignment check and guide cylinder inspection in accordance with Maintenance Standards or ship drawings as applicable.

Measure Guide Piston OD  
And Guide Cylinder ID  
at 0° and 90°

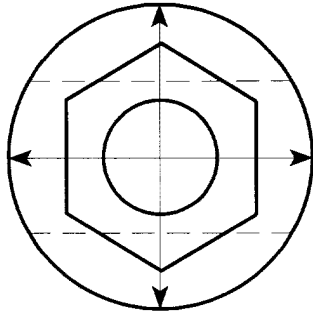

Measure Guide Piston OD and  
Guide Cylinder ID in 4 Places

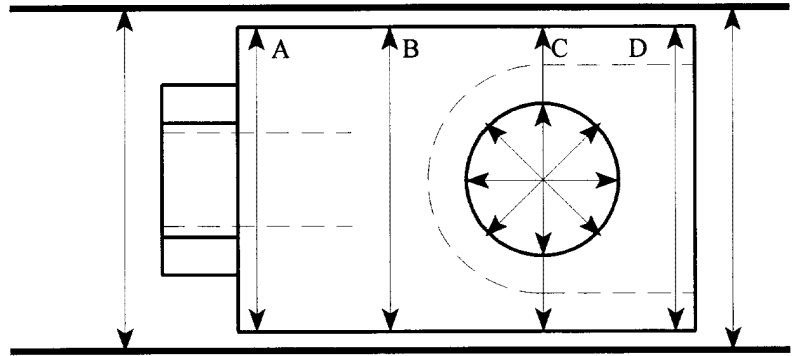

Measure Bore ID at  
0°, 45°, 90°, and 135°  
In 2 Places per Bushing

Guide Cylinder ID Measurements				
0°				
90°				
Average				

A B C D

Guide Piston OD Measurements				
0°				
90°				
Average				

A B C D

Wrist Pin Bore ID Measurements				
0°				
45°				
90°				
135°				
Average				

Figure 561-I-9 Guide Piston Measurement Worksheet

**Table 561-I-9** Summary of SSN 688 Class Guide Piston Modification Material Replacements

Item	Qty	Component	Materials	
			Existing	Replacement
1	8	Guide Piston Staves	(N/A)	Orkot TXM CID A-A-50602
2	2	Stave Retainers	(N/A)	Monel QQ-N-281, Form 6
3	8	Stave Retainer Bolts	(N/A)	Monel QQ-N-281, Form 6
4	- -	Lockwire	(N/A)	Monel QQ-N-281, Form 7
5	4	Vent Hole Plugs	(N/A)	Ni-Al-Brz Mil-B-24480
6	1	Threaded Insert	(N/A)	Ni-Al-Brz Mil-B-24480

**Table 561-I-10** Summary of SSBN 726 Class Guide Piston Modification Material Replacements

Item	Qty	Component	Materials	
			Existing	Replacement
1	12	Guide Piston Staves	(N/A)	Orkot TXM* CID A-A-50602
2	2	Stave Retainers	(N/A)	Monel QQ-N-281, Form 6
3	14	Stave Retainer Bolts	(N/A)	K-Monel QQ-N-286, Form 6
4	- -	Lockwire	(N/A)	Monel QQ-N-281, Form 7
5	2	Guide Piston Pin Plugs	(N/A)	Ni-Al-Brz QQ-C-465
6	1	Threaded Insert	(N/A)	Al-Brz

\*UHMWPE, ASTM D-4020, is also acceptable for guide piston staves.

### 561-I.5 THROUGH-HULL ROD SUPPORT BEARING REPAIR.

561-I.5.1 Purpose And Scope. These paragraphs provide detailed requirements for installation of the following SSN 688 and SSBN 726 Class submarine through-hull operating rod support bearing repairs:

#### 561-I.5.1.1 SSN 688 Class:

1. Replacing the existing Delrin bearing staves with UHMWPE (or equivalent) bearing staves with identical dimensions.
2. Replacing the existing tin bronze hull penetration gland bearing with a self-lubricated bearing with identical dimensions.

#### 561-I.5.1.2 SSBN 726 Class:

1. Modifying the existing intermediate operating rod support bearings and operating rod coupling to allow installation of Orkot TXM (or equivalent) self-lubricated sleeves.
2. Modifying the operating rods to allow installation of two additional intermediate support bearings.
3. Replacing the existing tin bronze hull penetration gland bearing with a self-lubricated bearing.

Note that if the operating rod diameter has been turned down at the hull penetration, the ID of the replacement hull penetration bearing must be sized accordingly.

These replacements will reduce noise, reduce wear on the operating rod bearings, provide insulation from galvanic corrosion and extend the period between replacement of these parts.

561-I.5.2 Repair Requirements. The SSN 688 and SSBN 726 Class submarine through-hull operating rod support bearings shall be modified to permit installation of self-lubricated bearing materials in accordance with the drawings, References [561-I.5.5.1](#), [561-I.5.5.2](#), and [561-I.5.5.3](#). The new self-lubricated bearing materials are identified in [Tables 561-I-11](#) and [561-I-12](#).

561-I.5.2.1 The new SSN 688 Class stave bearings shall be assembled in accordance with the original drawings, References [561-I.5.5.5](#) through [561-I.5.5.8](#).

561-I.5.2.2 All general requirements specified in [section 2](#) of this procedure shall be met when performing the bearing modifications and repairs.

561-I.5.2.3 Criteria to initiate these repairs during overhaul shall be MS's 5560-081-033, 5560-081-037, or 5560-081-038 (latest rev.) for SSN 688 Class or 5560-081-006 or 5560-081-007 (latest rev.) for SSBN 726 Class.

561-I.5.2.4 Criteria to initiate these repairs during a ships' operating cycle shall be based primarily on noise. As long as the components are not generating detectable noise and the system is operationally quiet, the repairs will not be initiated.

561-I.5.3 Detailed Installation Requirements. The following actions are required to accomplish this repair:

#### NOTE

The connecting rod, guide piston, and operating rod must be disassembled and removed in order to install these bearing modifications and repairs.

For SSN 688 Class submarines, the intermediate support bushings must be removed in order to install new staves.

For SSBN 726 Class submarines, the intermediate support bearings and operating rod coupling must be removed for modifications.

561-I.5.3.1 Disassemble the connecting rod, guide piston, and operating rod in accordance with NAVSEA drawings and established shipyard procedures.

561-I.5.3.2 Remove scale and corrosion buildup from operating rod and accessible portions of operating rod guide tube.

561-I.5.3.3 Inspect the operating rod, intermediate support bearing components, and operating rod guide tube for acceptability per Maintenance Standard requirements.

561-I.5.3.4 For SSN 688 Class submarines, machine new self-lubricated hull penetration bearing and new bearing staves in accordance with original NAVSEA drawings, Reference [561-I.5.5.5](#) through [561-I.5.5.8](#).

Follow precautions and guidance in [paragraphs 561-I.10](#) through [561-I.10.6](#) of this procedure for machining self-lubricated materials.

561-I.5.3.5 For SSBN 726 Class submarines, machine operating rods as necessary for new intermediate support bearings and machine new bearings in accordance with drawing, Reference [561-I.5.5.1](#).

561-I.5.3.6 For SSBN 726 Class submarines, machine new self-lubricated hull penetration bearing and bearing sleeves and in accordance with drawings, Reference [561-I.5.5.1](#) and [561-I.5.5.2](#).

Follow precautions and guidance in [paragraphs 561-I.10](#) through [561-I.10.6](#) of this procedure for machining self-lubricated materials.

561-I.5.3.7 Clean all surfaces of the intermediate support bearings, coupling, and accessible portions of guide tube ID until free of grease, scale, and other debris (using TKE or equal solvent).

561-I.5.3.8 Install new hull penetration bearings in accordance with drawing requirements.

561-I.5.3.9 For SSN 688 Class submarines, install staves in bushings and re-assemble in guide tube per NAVSEA drawings, References [561-I.5.5.5](#) through [561-I.5.5.8](#).

561-I.5.3.10 For SSBN 726 Class submarines, install bearing sleeves on support bearings and coupling in accordance with Reference [561-I.5.5.1](#).

561-I.5.3.11 Complete operating rod and bearing assembly and installation per NAVSEA drawings and established shipyard procedures.

561-I.5.4 Prior And/or Concurrent Alterations. The following prior ship alterations (shipalts) are applicable. The installation details are based on prior completion of these shipalts:

I.5.4.1 SSN 688 Class:

- a. None identified.

I.5.4.2 SSBN 726 Class:

- a. None identified.

561-I.5.5 References.

561-I.5.5.1 NAVSEA Drawing 7006697. "SSBN Trident Class, Steering and Diving Gear Guide Tube Bearing Modification."

561-I.5.5.2 NAVSEA Drawing 7006699. "SSBN Trident Class, Steering and Diving Gear Stuffing Box Bearing Modification."

561-I.5.5.3 Drawing for SSN 688 Class. Operating rod bearing modifications (later).

561-I.5.5.4 Report MPR-1760. "Submarine Steering and Stern Diving Gear Operating Rod Repair Criteria," prepared by MPR Associates, August 1996.

561-I.5.5.5 NAVSEA Drawing 4456071. "SSN 688 Class Submarine, Steering & Stern Diving Hull Penetrations Assembly & Details."

561-I.5.5.6 NAVSEA Drawing 4457075. "SSN 688 Class Submarine, Steering Gear Aft Operating Gear Assembly."

561-I.5.5.7 NAVSEA Drawing 4457077. "SSN 688 Class Submarine, Steering Gear Crosshead Housing & Bearing Detail."



- 561-I.5.5.8 NAVSEA Drawing 4457079. "SSN 688 Class Submarine, Stern Diving Gear Aft Operating Gear Assembly."
- 561-I.5.5.9 NAVSEA Drawing 4457081. "SSN 688 Class Submarine, Stern Diving Gear Crosshead Housing & Bearing Detail."
- 561-I.5.5.10 NAVSEA Drawing 4674747. "SSBN Trident Class, Steering Gear Assembly and Installation."
- 561-I.5.5.11 NAVSEA Drawing 4674751. "SSBN Trident Class, Steering/Diving Gear Misc. Details."
- 561-I.5.5.12 NAVSEA Drawing 4674752. "SSBN Trident Class, Steering/Diving Gear Guide Details."
- 561-I.5.5.13 NAVSEA Drawing 4674753. "SSBN Trident Class, Steering/Diving Gear Connecting Rod & Details."
- 561-I.5.5.14 NAVSEA Drawing 4674761. "SSBN Trident Class, Stern Diving Gear Assembly and Installation."
- 561-I.5.5.15 Maintenance Standard (MS) 5560-081-006. "Overhaul Stern Diving Gear Operation Linkage."
- 561-I.5.5.16 Maintenance Standard (MS) 5560-081-007. "Overhaul Steering Gear Operation Linkage."
- 561-I.5.5.17 Maintenance Standard (MS) 5560-081-033. "Restore External Parts of Steering Gear."
- 561-I.5.5.18 Maintenance Standard (MS) 5560-081-037. "Restore Fairwater Diving Gear."
- 561-I.5.5.19 Maintenance Standard (MS) 5560-081-038. "Restore External Parts of Stern Diving Gear."
- 561-I.5.5.20 General Dynamics, EBDiv Drawing 41056-566000. "Rudder Operating Rods, Bearings, and Coupling Replacement Procedure."
- 561-I.5.5.21 General Dynamics, EBDiv Drawing 41051-566000. "Stern Plane Operating Rods, Bearings, and Coupling Replacement Procedure."
- 561-I.5.5.22 Report MPR-1153. "Evaluation of Methods for Increasing the Wear Resistance of the Steering and Stern Diving Gear Operating Rod Bearings on SSN 688 Class Submarines," prepared by MPR Associates, October 1989.
- 561-I.5.5.23 Report 9560-SMMS-REP. "Evaluation of SSBN 726 Class Steering and Stern Diving Gear Operating Rod Support Bearings, Coupling, and Hull Penetration Bearing," prepared by MPR Associates, September 1991.
- 561-I.5.6 Maintenance Requirement Parts List. Refer to [Tables 561-I-11](#) and [Tables 561-I-12](#) for materials required to accomplish these repairs for the applicable submarine class.
- 561-I.5.6.1 For hull penetration bearings, refer to applicable NAVSEA drawings for detailed dimensions. Note that grease grooves and holes in hull penetration bearings are not to be included in replacement self-lubricated bearing parts.
- 561-I.5.6.2 For SSN 688 Class, bearing staves can be purchased as plate and field machined to the appropriate size per the original NAVSEA drawing.

561-I.5.6.3 For SSBN 726 Class, new split bearing sleeves are purchased in tube, sawed longitudinally into equal halves, and drilled for mounting screws.

561-I.5.7 Final Inspection. Perform connecting rod/operating rod alignment check in accordance with Maintenance Standards or ship drawings as applicable.

**Table 561-I-11** Summary of SSN 688 Class Operating Rod Support Bearing Material Replacements

Item	Qty	Component Applicable Dwg / Pc #	Materials	
			Existing	Replacement
1	20	Bearing Staves 4457077, Pc. 30 (steering) 4457081, Pc. 30 (stern diving)	Delrin AF	UHMWPE or Orkot TXM
2	1	Hull Penetration Bearing 4496071, Pc. 2 (stern diving) 4496071, Pc. 13 (steering)	Tin Bronze QQ-C-390, Type 3	Self-Lubricated Bearing CID A-A-50602

**Table 561-I-12** Summary of SSBN 726 Class Operating Rod Support Bearing Material Replacements

Item	Qty	Component Applicable Dwg / Pc #	Materials	
			Existing	Replacement
1	2	Intermediate Support Bearing	(N/A)	Ni-Al-Brz ASTM B150, Alloy C63200
2	2	Sleeve, Intermediate Support Bearing	(N/A)	Orkot TXM CID A-A-50602
3	1	Sleeve, Coupling	(N/A)	Orkot TXM CID A-A-50602
4	1	Hull Penetration Bearing 4674751, Pc. 12	Tin Bronze QQ-C-390, Type 2	Self-Lubricated Bearing CID A-A-50602

### 561-I.6 FAIRWATER PLANES STOCK BEARING REPAIR.

561-I.6.1 Purpose And Scope. These paragraphs provide detailed requirements for installation of SSN 688 and SSBN 726 Class submarine fairwater diving plane stock bearing repairs. The affected bearing components are illustrated in [Figure 561-I-10](#). The bearing repairs include the following:

#### 561-I.6.1.1 SSN 688 Class:

1. Substituting K-Monel (QQ-N-286) sleeves for existing Stellite (Alloy 21) sleeves.
2. Substituting self-lubricated bearings for existing Stellite (Alloy 20) bearings.
3. Substituting Orkot TXM or equivalent keeper rings for existing Nickel-Manganese-Bronze (NiMnBrz) keeper rings.

#### NOTE

Existing K-Monel bushings may be reused with this repair. If the bushings require replacement, Nickel-Aluminum-Bronze (MIL-B-24480) is a suitable material.

#### 561-I.6.1.2 SSBN 726 Class:

1. Substituting K-Monel stock sleeves for existing Stellite (Alloy 20) sleeves.

2. Substituting self-lubricated plain journal bearings for existing Stellite (Alloy 21) spherical bearing rings.
3. Substituting Nickel-Aluminum-Bronze (MIL-B-24480) bushings/retainers for existing K-Monel (Alloy 16) bushings.
4. Substituting UHMWPE, Orkot TXM, or equivalent keeper rings (retainer rings) for existing Nickel-Aluminum-Bronze (NiAlBrz) keeper rings.

These replacements will eliminate greasing requirements, reduce noise, reduce wear on the bushings, provide insulation from galvanic corrosion and extend the period between replacement of these parts.

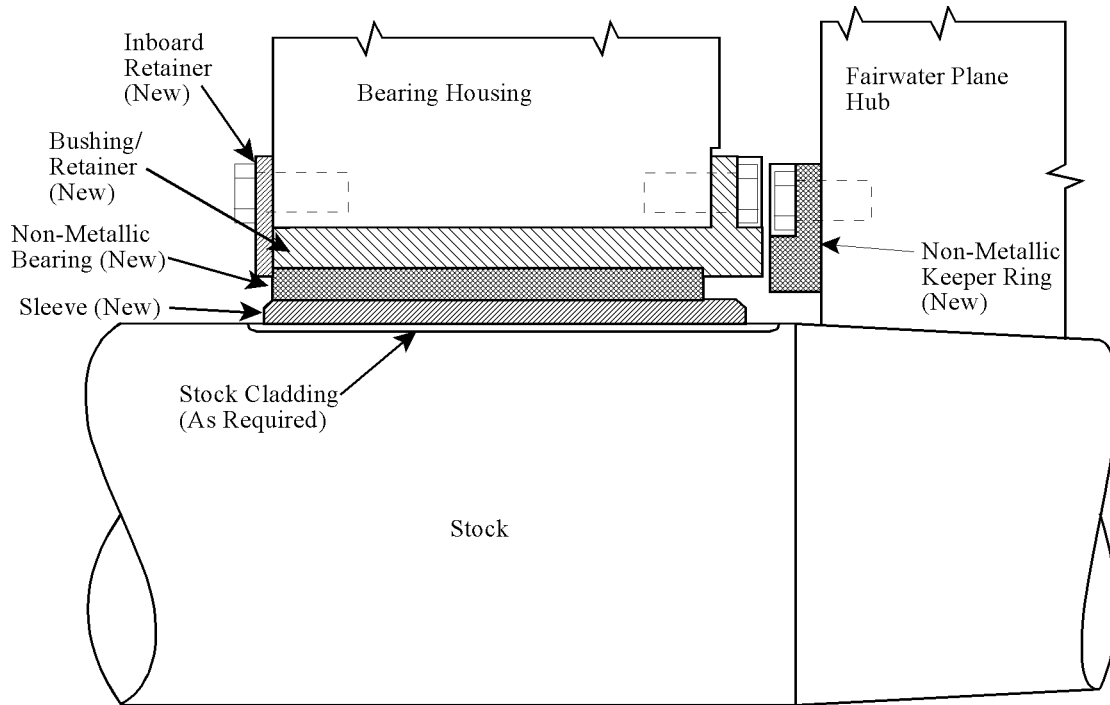

Figure 561-I-10 Typical Fairwater Diving Plane Stock Bearing Repairs

561-I.6.2 Repair Requirements. The metallic bearings and keeper rings associated with the SSN 688 and SSBN 726 Class submarine fairwater stock bearing assemblies shall be replaced with self-lubricated, extended wear parts in accordance with drawings, References 561-I.6.5.1 and 561-I.6.5.2. In addition, mating metallic bearing components will be replaced with K-Monel parts for compatibility with the mating components.

561-I.6.2.1 All general requirements specified in paragraphs 561-I.2 through 561-I.2.16.3 of this procedure shall be met when performing the bearing modifications and repairs.

561-I.6.2.2 Criteria to initiate these repairs during overhaul shall be MS's 5560-081-037 (latest rev.) for SSN 688 Class or MS 5560-081-005 (latest rev.) for SSBN 726 Class.

561-I.6.2.3 Criteria to initiate these repairs during a ships' operating cycle shall be based primarily on noise. As long as the components are not generating detectable noise and the system is operationally quiet, the repairs will not be initiated.

561-I.6.2.4 The clearance limits following repair shall be as specified on the drawings, References 561-I.6.5.1 and 561-I.6.5.2.

561-I.6.3 Detailed Installation Requirements. The following installation actions are required to accomplish this repair:

561-I.6.3.1 Remove the fairwater diving planes from the submarine. Removal and re-installation of these heavy components is accomplished in accordance with existing NAVSEA drawings and established shipyard procedures. General Dynamics Electric Boat Drawing No. 41024-566000 (latest rev.) is a suggested handling procedure for SSBN 726 Class submarines.

561-I.6.3.2 Support the stock to unload the stock bearings. Remove the two (port and starboard) bearing assemblies. Use the jacking screws provided.

561-I.6.3.3 Remove the stock assembly from the sail in accordance with existing drawings and shipyard practices.

561-I.6.3.4 Disconnect the existing grease lines serving the fairwater plane stock bearings. Remove the flex hose tubing of the applicable grease lines between the bearing connections and the nearest terminal block. Remove the tube fittings from the bearing connection and plug the vacant orifices. Apply PR-380M thread sealant to plug threads prior to installation. Also plug the appropriate grease line terminal block/grease manifold ports and tube ends. Re-label greasing manifold accordingly.

561-I.6.3.5 Remove the existing stock sleeves from the stock.

561-I.6.3.6 Remove the existing bushings from fairwater housings.

561-I.6.3.7 Inspect condition of stock and bearing housings for acceptability per Maintenance Standard requirements.

561-I.6.3.8 Clean all grease, rust, and corrosion from the stock, bushings (SSN 688 Class only, if reused), and housing IDs. Refurbish stock, bushing, and/or housing surfaces as necessary to restore to original design conditions. Contact NAVSEA 92T for guidance on acceptable processes and procedures for stock repairs.

561-I.6.3.9 Preserve exposed stock surfaces with epoxy paint (Mil-P-23236, Type 1, Class 2) in accordance with the applicable NAVSEA drawings.

561-I.6.3.10 Using [Figure 561-I-11](#), measure and record stock OD, fairwater housing ID, and bearing retainer ID dimensions for fit-up and compliance with design drawing dimensional criteria. Correct housing ID out-of-roundness as necessary.

561-I.6.3.11 Final machine bearing retainer OD as necessary for proper fit up with housing ID in accordance with drawings, Reference [561-I.6.5.1](#) and [561-I.6.5.2](#).

561-I.6.3.12 Use the measured stock OD to determine the replacement sleeve final dimensions. Machine replacement sleeves to the final dimensions specified in accordance with drawings, Reference [561-I.6.5.1](#) and [561-I.6.5.2](#).

561-I.6.3.13 Heat new sleeves to 300 to 500°F using an oven or heating blanket. Do not use a torch. Install sleeves on stock using even pressure all around the edge of the sleeve. A solid stop should be used to control positioning of the sleeves on the stock.

561-I.6.3.14 After the sleeves have cooled, wrap the stock sleeve surface with a soft rubber sheet (about 1/8 to 1/4 inch thick) and tape the sheet to the stock to protect the sleeve while installing the stock. Leave the rubber sheet in place until after the stock has been positioned and the bearings are ready to be installed.

561-I.6.3.15 Measure the replacement self-lubricated bearing ID, determine press fit, and verify adequate final clearance per drawing, as shown below.

#### NOTE

Use the highest press fit in the required range in order to minimize the final clearance.

Port

Stbd

Measure bearing ID in four places 45° apart and record average:

Enter required bearing press fit:

Installed bearing ID (measured ID minus press fit):

Measure installed sleeve OD in four places 45° apart and record average:

Final installed clearance (installed bearing ID minus installed sleeve OD):

561-I.6.3.16 Use the measured bushing/retainer ID and desired bearing press fit (from above) to verify the replacement self-lubricated bearing OD.

Port

Stbd

Enter average bushing/retainer ID (Figure 561-I-10):

Enter bearing press fit (paragraph 561-I.6.3.15):

Final bearing OD (bushing/retainer ID plus press fit):

561-I.6.3.17 Final machine self-lubricated bearings as necessary. Follow precautions and guidance in paragraph 561-I.10 of this procedure when machining the self-lubricated bearing components. Tag each bushing and indicated the location where the component is to be installed (for example: "connecting rod-tiller end").

#### NOTE

Do not machine grease holes and grease grooves in replacement bearing components.

561-I.6.3.18 Clean all surfaces of remaining components that contact self-lubricated bearing components until free of grease and debris.

561-I.6.3.19 Press bearings into bushings as follows:

561-I.6.3.19.1 Fabricate a light weight (e.g., aluminum) arbor or press plate. Also fabricate spacer blocks to provide a positive stop, as shown below, if necessary.

561-I.6.3.19.2 Prepare bushing/retainer bore ID by roughing with 50-60 grit sandpaper.

561-I.6.3.19.3 Chill bearings in a dry ice and alcohol bath (-100 F). Liquid nitrogen may also be used.

561-I.6.3.19.4 Place bushing/retainer in press with flange facing down.

561-I.6.3.19.5 Spread a thin coat of epoxy or Loctite adhesive over the bushing ID using a plastic spatula or putty knife. Skim off excess using a 12 to 18 tooth hacksaw blade.

#### NOTE

Mix and apply adhesive according to manufacturer's directions.

561-I.6.3.19.6 If necessary, place four 1" spacers around the inside of the bushing/retainer to stop the bearing in the proper place when it is pressed in place.

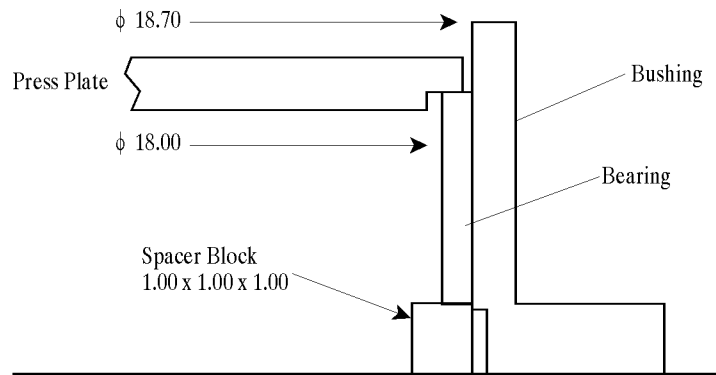

Figure 561-I-11 Bearing/Bushing Assembly (SSN 688 Class Shown)

561-I.6.3.19.7 Place bearing into the bushing/retainer, making sure the bearing is not cocked. Use the arbor or press plate as necessary to press the bearing into place using even pressure all around the edge of the bearing. This step must be performed before the bearing is allowed to warm up.

561-I.6.3.19.8 Wipe all excess adhesive from the bearing and bushing using clean cloths. Use a small amount of solvent on the cloth for the final pass.

561-I.6.3.19.9 Allow the bearing adhesive to set per the manufacturer's instructions.

#### NOTE

A small amount of mixed adhesive should be saved as a test sample to determine when the adhesive has properly hardened.

561-I.6.3.19.10 Measure the final installed bearing ID and compare to the value calculated in [paragraph 561-I.6.3.15](#) to verify proper clearance will be achieved.

561-I.6.3.20 Install the stock in accordance with the applicable NAVSEA drawings and established shipyard procedures.

561-I.6.3.21 Lift and center the stock in the fairwater housing bores. Remove the protective sheet from the sleeves.

561-I.6.3.22 Chill bushings to approximately 100 F below ambient temperature at installation.

561-I.6.3.23 Gently guide each bushing/retainer over the stock and into place in the housing. Use extreme caution to prevent damage to the bearing components. Carefully push the bushing/retainer into the housing using even pressure all around the outside of the bushing.

#### NOTE

Tapered wooden or plastic slats may be taped to the stock to guide the bushing over the sleeve.

**NOTE**

Do not lift or support the bushing/retainer with a chain or rope through the bearing bore.  
Use a shackle through one of the bushing/retainer mounting bolt holes.

561-I.6.3.24 Install inboard retainer plate.

561-I.6.3.25 Tighten bushing/retainer mounting bolts in accordance with applicable NAVSEA drawings.

561-I.6.3.26 Replace keeper rings on each fairwater plane and tighten mounting bolts in accordance with applicable NAVSEA drawings.

561-I.6.3.27 Install the fairwater planes and reassemble the remaining components in accordance with applicable NAVSEA drawings.

561-I.6.3.28 Spray water on the bearing surfaces prior to exercising the planes.

561-I.6.4 Prior And/or Concurrent Alterations. The following prior ship alterations (shipalts) are applicable. The installation details are based on prior completion of these shipalts:

561-I.6.4.1 SSN 688 Class:

- a. SSN 688-3603 - - Replaces fairwater stock bearings (uses Alloy 20 and 21 replacement materials).
- b. SSN 688-3604 - - Modifies stock bearing keeper ring dimensions/shape.

561-I.6.4.2 SSBN 726 Class:

- a. TRID-0274 - - Replaces Fairwater stock bearings (uses Alloy 20 and 21 replacement materials).

561-I.6.5 References.

561-I.6.5.1 MPR Drawing 1059-126-13. "SSN 688 Class, Fairwater Diving Stock Bearing Repair, Non-Metallic Bearings."

561-I.6.5.2 General Dynamics, EBDiv, Engineering Notice DM 120888. "Main Stock Journal Bearings and Thrust Bearing." [Fairwater Diving Gear]

561-I.6.5.3 NAVSEA Drawing 4403812. "SSN 688 Class Submarine, Fairwater Diving Planes Stock & Bearings."

561-I.6.5.4 NAVSEA Drawing 4643402. "SSBN Trident Class, Fairwater Diving Planes Stock and Details."

561-I.6.5.5 NAVSEA Drawing 4673405. "SSBN Trident Class, Fairwater Diving Planes Bearings."

561-I.6.5.6 Maintenance Standard (MS) 5560-081-005. "Overhaul Fairwater Diving Gear."

561-I.6.5.7 Maintenance Standard (MS) 5560-081-037. "Restore Fairwater Diving Gear."

561-I.6.5.8 General Dynamics, EBDiv Drawing 41024-566000. "Fairwater Plane Replacement Procedure."

561-I.6.5.9 Report MPR-1017. "Analysis of Tuffite Sleeves for use in SSBN 726 Class Submarine Fairwater Plane Stock Bearings," prepared by MPR Associates.

561-I.6.5.10 DTRC 9073 Code 2744POP: David Taylor Research Center. "Temporary Alteration Technical Data Package: Fairwater Diving Planes Bearings, SSBN 726 Class Submarines", including DTRC drawing A27-20023-1 through A27-20023-5.

561-I.6.6 Maintenance Requirement Parts List.

561-I.6.6.1 Refer to [Tables 561-I-13](#) and [561-I-14](#) and drawings, References [561-I.6.5.1](#) and [561-I.6.5.2](#) for materials required to accomplish these repairs for the applicable submarine class.

#### NOTE

The ordering dimensions specified in the referenced drawings include allowance for field machining components to the final dimensions. Field machining is done after as-built measurements are performed.

561-I.6.7 Final Inspection. Perform and record stock bearing diametral and thrust clearance measurements in accordance with Maintenance Standards or ship drawings as applicable.



Stock and Housing Measurements (After any Refurbishing)				
Location	Port		Starboard	
	Stock OD	Housing ID	Stock OD	Housing ID
0°				
45°				
90°				
135°				
Average				

Bearing Retainer Measurements				
Location	Port		Starboard	
	ID	OD	ID	OD
0°				
45°				
90°				
135°				
Average				

Bearing Measurements								
Location	Port Side				Starboard Side			
	ID		OD		ID		OD	
	Inbd	Outbd	Inbd	Outbd	Inbd	Outbd	Inbd	Outbd
0°								
45°								
90°								
135°								
Average								

Figure 561-I-12 Bearing Measurement Worksheet

**Table 561-I-13** Summary of SSN 688 Class Fairwater Stock Bearing Material Replacements

Item	Qty	Component Applicable Dwg / Pc #	Materials	
			Existing	Replacement
1	1	Bushing/Retainer 4403812/Pc 12 and 13	H-Monel Alloy 16, Mil-C-15345G	Ni-Al-Bronze Mil-B-24480
2	2	Bearing 4403812/Pc 15	Stellite Alloy 21, Mil-C-15345G	Self-Lubricated Bearing CID A-A-50602
3	2	Sleeve 4403812/Pc 16	Stellite Alloy 20, Mil-C-15345G	K-Monel QQ-N-286F
4	2	Keeper Ring 4403812/Pc 18	Al-Mn-Brz QQ-C-390, Alloy C5	Orkot TXM CID A-A-50602

**Table 561-I-14** Summary of SSBN 726 Class Fairwater Stock Bearing Material Replacements

Item	Qty	Component Applicable Dwg / Pc #	Materials	
			Existing	Replacement
1	2	Bushing/Retainer 4643405 / Pc 24	H-Monel Alloy 16, Mil-C-15345G	Ni-Al-Bronze Mil-B-24480
2	2	Bearing Ring 4643405 / Pc 90	Stellite Alloy 21, Mil-C-15345G	Self-Lubricated Bearing CID A-A-50602
3	2	Sleeve 4643402 / Pc 20	Stellite Alloy 20, Mil-C-15345G	K-Monel QQ-N-286F
4	2	Keeper/Retainer Ring 4643405 / Pc 3	Ni-Al-Brz Mil-B-24480	UHMWPE ASTM D-4020
5	2	Inboard Retaining Ring	N/A	Monel, QQ-N-281
6	12	Keeper Ring Metallic Insert	N/A	Monel, QQ-N-281

**561-I.7 STERN PLANES STOCK BEARING REPAIR.**

561-I.7.1 Purpose And Scope. These paragraphs provide detailed requirements for installation of SSN 688 and SSBN 726 Class submarine stern diving plane stock bearing repairs. The affected bearing components are illustrated in [Figure 561-I-12](#). The bearing repairs include the following:

- a. Substituting K-Monel (QQ-N-286) sleeves for existing Stellite (Alloy 21) stock sleeves.
- b. Substituting self-lubricated bearings for existing Stellite (Alloy 20) bushings and installing a new Monel (QQ-N-281) retainer.
- c. Installing a new UHMWPE, Orkot TXM, or equivalent split thrust bearing mounted to a new Nickel-Aluminum-Bronze split retainer/clamping ring. The keeper ring on the yoke is not modified.

**NOTE**

When the stern planes are removed to accomplish these repairs, the pintle bearings shall be replaced in accordance with [paragraphs 561-I.8 through 561-I.8.7](#) of this procedure.

561-I.7.1.1 These replacements will eliminate greasing requirements, reduce noise, reduce wear on the bushings, provide insulation from galvanic corrosion and extend the period between replacement of these parts.

561-I.7.2 Repair Requirements. The metallic bearings and keeper rings associated with the SSN 688 and SSBN 726 Class submarine stern plane stock bearing assemblies shall be replaced with self-lubricated, extended wear parts in accordance with drawings, References 561-I.7.5.1 and 561-I.7.5.2. In addition, the mating metallic bearing components will be replaced with K-Monel parts for compatibility with the mating components.

561-I.7.2.1 All general requirements specified in paragraphs 561-I.2 through 561-I.2.16.3 of this procedure shall be met when performing the bearing modifications and repairs.

561-I.7.2.2 Criteria to initiate these repairs during overhaul shall be MS 5560-081-038 (latest rev.) for SSN 688 Class or MS 5560-081-008 (latest rev.) for SSBN 726 Class.

561-I.7.2.3 Criteria to initiate these repairs during a ships' operating cycle shall be based primarily on noise. As long as the components are not generating detectable noise and the system is operationally quiet, the repairs will not be initiated.

561-I.7.2.4 The clearance limits following repair shall be as specified on the drawings, References 561-I.7.5.1 and 561-I.7.5.2.

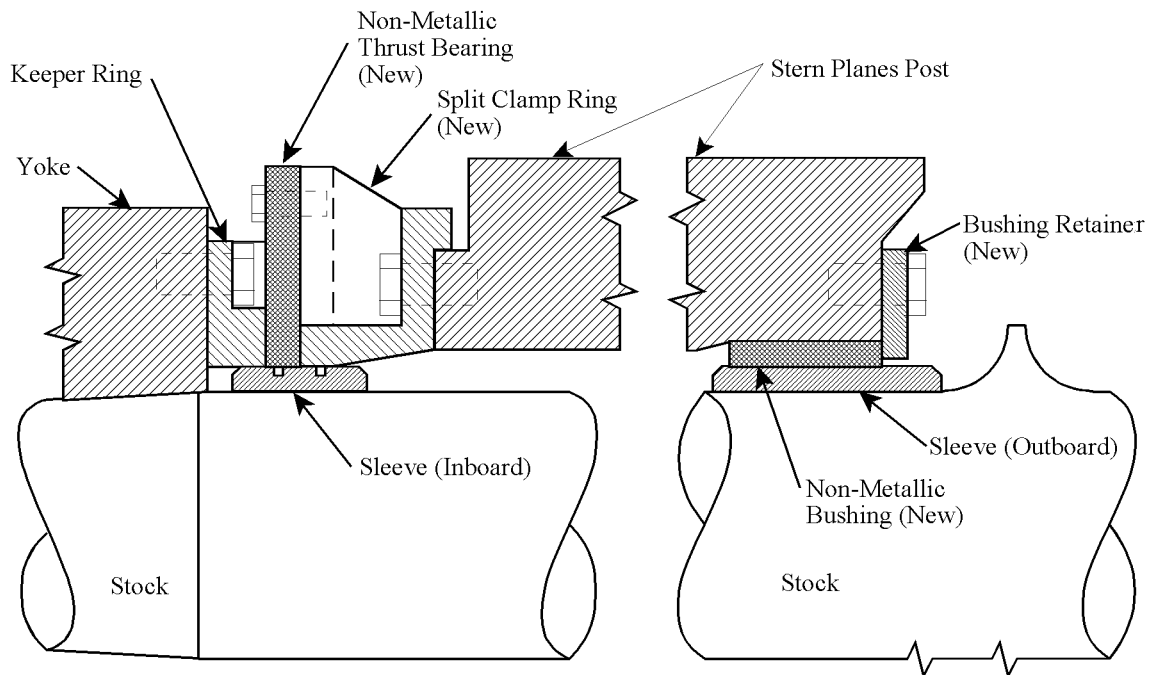

Figure 561-I-13 Typical Stern Diving Plane Stock Bearing Repairs

561-I.7.3 Detailed Installation Requirements. The following installation actions are required to accomplish this repair:

561-I.7.3.1 Disassemble pintle bearings and remove stern diving plane and stock assemblies from the submarine. Removal and re-installation of these heavy components is accomplished in accordance with existing NAVSEA drawings and standard shipyard practices. General Dynamics/Electric Boat Drawing No. 41021-566000 (latest rev.) is a suggested handling procedure for SSBN 726 Class submarines.

561-I.7.3.2 Disassemble the port and/or starboard bushings from the stern plane bearing post.

561-I.7.3.3 Disassemble the port and/or starboard retainer/clamp rings from the bearing post.

561-I.7.3.4 Remove the inboard and outboard stock sleeves from the stocks.

561-I.7.3.5 Disconnect the existing grease lines serving the stern plane stock bearings. Remove the flex hose tubing of the applicable grease lines between the bearing connections and the nearest terminal block. Remove the tube fittings from the bearing connection and plug the vacant orifices. Apply PR-380M thread sealant to plug threads prior to installation. Also plug the appropriate grease line terminal block/grease manifold ports and tube ends. Re-label greasing manifold accordingly.

561-I.7.3.6 Inspect condition of stocks, inboard sleeves, and bearing posts for acceptability per Maintenance Standard requirements.

561-I.7.3.7 Clean all grease, rust, and corrosion from the stocks, inboard sleeves, and posts. Refurbish stock and post surfaces as necessary to restore to original design conditions. Refurbish or replace inboard stock sleeves as required. Contact NAVSEA 92T for guidance on acceptable processes and procedures for stock repairs. Preserve exposed stock surfaces with epoxy paint (Mil-P-23236, Type 1, Class 2) in accordance with the applicable NAVSEA drawings.

561-I.7.3.8 Using [Figure 561-I-13](#), measure and record stock and bearing post diameters for fit-up and compliance with design drawing dimensional criteria. Correct any post ID out-of-roundness as necessary and re-measure post ID.

561-I.7.3.9 Use the measured stock OD to determine the replacement outboard sleeve ID.

Port	Stbd
------	------

Average stock OD ([Figure 561-I-13](#)):

Enter required sleeve shrink fit:

Final sleeve ID (stock OD minus shrink fit):

561-I.7.3.10 Machine replacement sleeves to the final dimensions specified in accordance with drawings, References [561-I.7.5.1](#) and [561-I.7.5.2](#).

561-I.7.3.11 Heat new outboard sleeves to 300 to 500°F using an oven or heating blanket. Do not use a torch. Install sleeves on stock using even pressure all around the edge of the sleeve. A solid stop should be used to control positioning of the sleeves on the stock.

561-I.7.3.12 After the sleeves have cooled, wrap the stock sleeve surface with a soft rubber sheet (about 1/8 to 1/4 inch thick) and tape the sheet to the stock to protect the sleeve until the stock/planes are re-installed.

561-I.7.3.13 Install inboard sleeves per [paragraph 561-I.7.3.11](#).

561-I.7.3.14 Use [Figure 561-I-13](#) to measure the replacement bushing ID. Select the highest press fit in the required range in order to minimize the final clearance. Verify adequate final clearance as follows:

Port	Stbd
------	------

Average bushing ID ([Figure 561-I-13](#)):

Enter required bushing press fit:

Installed ID (measured ID minus press fit):

Measure installed sleeve OD in four places 45° apart and record average:

Final installed clearance (installed bushing ID minus installed sleeve OD):

561-I.7.3.15 Use the measured bearing post ID to determine the required bushing OD.

Port

Stbd

Average post ID (Figure 561-I-13):

Enter bushing press fit (see above):

Final bushing OD (post ID plus press fit):

561-I.7.3.16 Machine replacement bushings to the final dimensions specified in accordance with drawings, References 561-I.7.5.1 and 561-I.7.5.2. Follow precautions and guidance in section 561-I.10 of this procedure when machining the self-lubricated bearing components.

#### NOTE

Do not machine grease holes and grease grooves in replacement bearing components.

561-I.7.3.17 Measure port and starboard thrust clearances and size the required thickness of the thrust bearing:

Port

Stbd

Clamp ring-to-keeper ring gap:

Desired final clearance:

Final bearing thickness (gap minus final clearance):

561-I.7.3.18 Machine thrust bearings to the final dimensions specified in accordance with drawings, References 561-I.7.5.1 and 561-I.7.5.2. Follow precautions and guidance in section 10 of this procedure when machining the self-lubricated bearing components.

561-I.7.3.19 Clean all surfaces of remaining components that contact self-lubricated bearing components until free of grease and debris.

561-I.7.3.20 Chill bushings in dry ice or liquid nitrogen. Carefully install bushing into post, making sure the bushing is not cocked, and using even pressure all around the edge of the bushing. Complete this step before the bushing is allowed to warm up.

561-I.7.3.21 Install new bushing retainer plates on bearing post.

561-I.7.3.22 Install thrust bearing halves on new split retainer/clamping rings, and install retainer/clamping rings on bearing post.

561-I.7.3.23 Install each diving plane/stock assembly in accordance with the applicable NAVSEA drawings and established shipyard procedures. Use extreme caution and ensure stock is centered when guiding the stock through the bushing to prevent damage to the bearing components.

561-I.7.3.24 Verify all fasteners are tightened in accordance with applicable NAVSEA drawings.

561-I.7.3.25 Complete assembly of remaining components in accordance with applicable NAVSEA drawings.

561-I.7.3.26 Spray water on bearing surfaces prior to exercising the planes in drydock.

561-I.7.4 Prior And/or Concurrent Alterations. The following prior ship alterations (shipalts) are applicable. The installation details are based on prior completion of these shipalts:

561-I.7.4.1 SSN 688 Class:

a. SSN 688-3445 -- Modifies stern planes keeper rings to relieve interference between the keeper ring and the clamping piece.

561-I.7.4.2 SSBN 726 Class: None identified.

561-I.7.5 References.

561-I.7.5.1 MPR Drawing 1059-126-37. "SSN 688 Class, Stern Diving Stock Bearing Repair, Non-Metallic Bearings."

561-I.7.5.2 General Dynamics, EBDiv, Engineering Notice DM 120889. "Main Stock Journal Bearings, Pintle Journal Bearings, and Thrust Bearing." [Stern Diving Gear]

561-I.7.5.3 NAVSEA Drawing 4403816. "SSN 688 Class Submarine, Stern Diving Plane Stocks, Pintles, Bearings & Yoke."

561-I.7.5.4 NAVSEA Drawing 4643344. "SSBN Trident Class, Stern Plane Stock, Yoke, Bearing & Post."

561-I.7.5.5 Maintenance Standard (MS) 5560-081-008. "Overhaul Stern Diving Gear (Drydocking Required)."

561-I.7.5.6 Maintenance Standard (MS) 5560-081-038. "Restore External Parts of Stern Diving Gear."

561-I.7.5.7 General Dynamics, EBDiv Drawing 41021-566000. "Stern Plane Replacement Procedure."

561-I.7.6 Maintenance Requirement Parts List. Refer to the [Tables 561-I-15](#) and [Tables 561-I-16](#), and drawings, References 561-I.7.5.1 and 561-I.7.5.2, for materials required to accomplish these repairs for the applicable submarine class.

#### NOTE

The ordering dimensions specified in the referenced drawing include allowance for field machining components to the final dimensions. Field machining is done after as-built measurements are performed.

561-I.7.7 Final Inspection. Perform and record stock bearing diametral and thrust clearance measurements in accordance with Maintenance Standards or ship drawings as applicable.

Stock OD Measurements (After any Refurbishing)				
Location	At Port Outboard Sleeve		At Starboard Outboard Sleeve	
	Outboard Edge	Inboard Edge	Inboard Edge	Outboard Edge
0°				
45°				
90°				
135°				
Average				

Post ID Measurements (After any Refurbishing)				
Location	At Port Bearing		At Starboard Bearing	
	Outboard Edge	Inboard Edge	Inboard Edge	Outboard Edge
0°				
45°				
90°				
135°				
Average				

Bushing Measurements						
Location	Port Side			Starboard Side		
	Bushing ID	Bushing OD <sup>(1)</sup>	Bushing OD <sup>(2)</sup>	Bushing ID	Bushing OD <sup>(1)</sup>	Bushing OD <sup>(2)</sup>
0°						
45°						
90°						
135°						
Average						

1. Prior to machining final OD.

2. After machining final OD.

Figure 561-I-14 Bearing Measurement Worksheet

**Table 561-I-15** Summary of SSN 688 Class Stern Plane Stock Bearing Material Replacements

Item	Qty	Component Applicable Dwg / Pc #	Materials	
			Existing	Replacement
1	2	Bushing 4403816/Pc 12	Stellite Alloy 20, Mil-C-15345G	Self-Lubricated Bearing CID A-A-50602
2	2	Sleeve (Outboard) 4403816/Pc 11	Stellite Alloy 21, Mil-C-15345G	K-Monel QQ-N-286F
3	2	Bushing Retainer Ring	N/A	Monel QQ-N-281, Cl. A
4	2	Sleeve (Inboard) 4403816/Pc 19	Gun Metal QQ-C-390	Gun Metal QQ-C-390, Al. C90300
5	4	Split Clamp Ring 4403816/Pc 15	Al-Mn-Brz Alloy C5, QQ-C-390	Ni-Al-Brz MIL-B-24480
6	4	Split Thrust Bearing	N / A	UHMWPE ASTM D-4020

**Table 561-I-16** Summary of SSBN 726 Class Stern Plane Stock Bearing Material Replacements

Item	Qty	Component Applicable Dwg / Pc #	Materials	
			Existing	Replacement
1	2	Bushing 4643344/Pc 9	Stellite Alloy 20, Mil-C-15345G	Self-Lubricated Bearing CID A-A-50602
2	2	Sleeve (Outboard) 4643344/Pc 7	Stellite Alloy 21, Mil-C-15345G	K-Monel QQ-N-286F
3	2	Bushing Retainer Ring	N/A	Monel QQ-N-281, Cl. A
4	2	Sleeve (Inboard) 4643344/Pc 8	Gun Metal QQ-C-390, Al. 05	Gun Metal QQ-C-390, Al. C90300
5	4	Split Clamp Ring 4643344/Pc 6	Ni-Al-Brz Mil-B-24480	Ni-Al-Brz Mil-B-24480
6	4	Split Thrust Bearing	N/A	UHMWPE ASTM D-4020

**561-I.8 STERN DIVING PLANES PINTLE BEARING REPAIR.**

561-I.8.1 Purpose And Scope. These paragraphs provide detailed requirements for installation of SSN 688 and SSBN 726 Class submarine stern diving plane pintle bearing repairs. The affected bearing components are illustrated in [Figure 561-I-14](#). The bearing repairs include the following:

- a. Substituting self-lubricated bearings for existing Stellite spherical bearings (Alloy 20).
- b. Substituting K-Monel (QQ-N-286) sleeves for existing Stellite sleeves (Alloy 21).
- c. Substituting Nickel-Aluminum-Bronze (MIL-B-24480) bearing retainers for existing H-Monel (Alloy 16) bearing retainers.



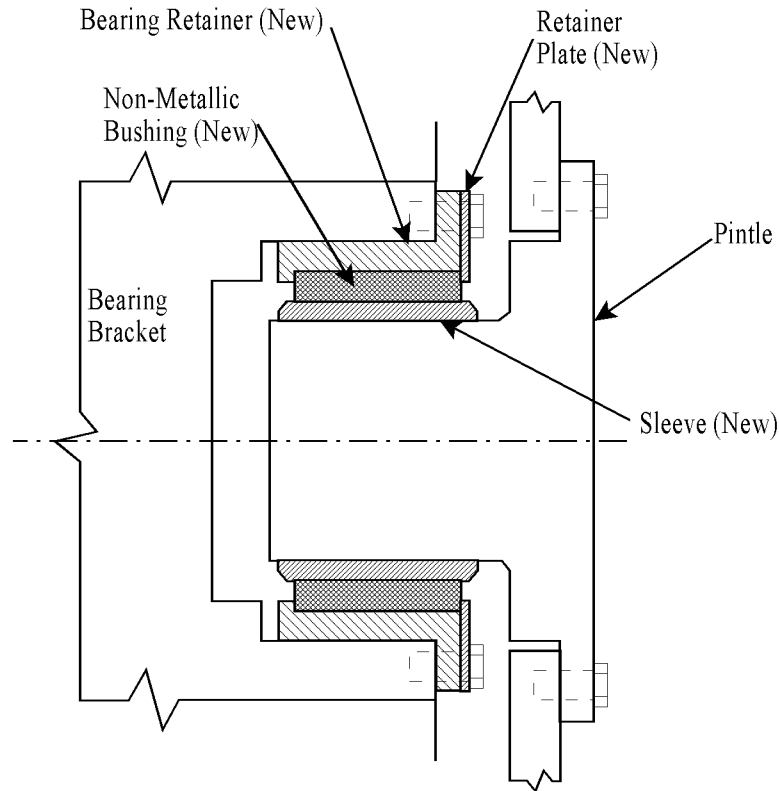

Figure 561-I-15 Typical Stern Diving Plane Pintle Bearing Repair

**NOTE**

These replacements will eliminate greasing requirements, reduce noise, reduce wear on the bushings, provide insulation from galvanic corrosion and extend the period between replacement of these parts.

561-I.8.2 Repair Requirements. The metallic bearings associated with the SSN 688 and SSBN 726 Class submarine stern diving gear pintle bearing assemblies will be replaced with self-lubricated, extended wear parts in accordance with drawings, References [561-I.8.5.1](#) and [561-I.8.5.2](#). In addition, the mating metallic bearing components will be replaced with K-Monel parts for compatibility with the mating surfaces.

561-I.8.2.1 All general requirements specified in [paragraphs 561-I.2](#) through [561-I.2.16.3](#) of this procedure shall be met when performing the bearing modifications and repairs.

561-I.8.2.2 Criteria to initiate these repairs during overhaul shall be MS's 5560-081-038 (latest rev.) for SSN 688 Class or MS 5560-081-008 (latest rev.) for SSBN 726 Class.

561-I.8.2.3 Criteria to initiate these repairs during a ships' operating cycle shall be based primarily on noise. As long as the components are not generating detectable noise and the system is operationally quiet, the repairs will not be initiated.

561-I.8.2.4 The clearance limits following repair shall be as specified on the drawings, References [561-I.8.5.1](#) and [561-I.8.5.2](#).

561-I.8.3 Detailed Installation Requirements. The following installation actions are required to accomplish this repair:

561-I.8.3.1 Disassemble stern plane pintle bearings and remove pintle and pintle bearings from the submarine. Removal and re-installation of these components is accomplished in accordance with existing NAVSEA drawings and standard shipyard practices.

561-I.8.3.2 Remove the sleeves from the pintles.

561-I.8.3.3 Disconnect the existing grease lines serving the stern plane pintle bearings. Remove the flex hose tubing of the applicable grease lines between the bearing connections and the nearest terminal block. Remove the tube fittings from the bearing connection and plug the vacant orifices. Apply PR-380M thread sealant to plug threads prior to installation. Also plug the appropriate grease line terminal block/grease manifold ports and tube ends. Re-label greasing manifold accordingly.

561-I.8.3.4 Inspect condition of pintle and bearing components for acceptability per Maintenance Standard requirements.

561-I.8.3.5 Clean all grease, rust, and corrosion from the pintles and bearing brackets and covers. Refurbish pintle and bearing brackets as necessary to restore to original design conditions.

561-I.8.3.6 Using [Figure 561-I-15](#), measure and record pintle OD, bearing bracket ID, and bearing retainer diameters for fit-up and compliance with design drawing dimensional criteria. Correct bracket ID out-of-roundness as necessary.

561-I.8.3.7 Final machine bearing retainer OD as necessary for proper fit up with bearing bracket ID in accordance with drawings, References [561-I.8.5.1](#) and [561-I.8.5.2](#).

Port Stbd

Average bracket ID ([Figure 561-I-15](#)):

Enter bushing clearance or press fit:

Final bushing OD (bracket ID plus press or minus clearance):

561-I.8.3.8 Use the measured pintle OD to determine the replacement sleeve final dimensions.

Port Stbd

Average pintle OD ([Figure 561-I-15](#)):

Enter sleeve shrink fit:

Final sleeve ID (pintle OD minus shrink fit):

561-I.8.3.9 Machine replacement sleeves to the final dimensions specified in accordance with drawings, References [561-I.8.5.1](#) and [561-I.8.5.2](#).

561-I.8.3.10 Heat new sleeves to 300 to 500°F using an oven or heating blanket. Do not use a torch. Install sleeves on pintles using even pressure all around the edge of the sleeve.

561-I.8.3.11 After the sleeves have cooled, wrap the sleeve surface with a soft rubber sheet (about 1/8 to 1/4 inch thick) and tape the sheet to the pintle to protect the sleeve until the pintles are re-installed.

561-I.8.3.12 Use [Figure 561-I-15](#) to measure the replacement bushing ID. Select the highest press fit in the required range in order to minimize the final clearance. Verify adequate final clearance as follows:

Port Stbd

Average bushing ID ([Figure 561-I-15](#)):

Enter required bushing press fit:

Installed ID (measured ID minus press fit):

Measure installed sleeve OD in four places 45° apart and record average:

Final installed clearance (installed bushing ID minus installed sleeve OD):

561-I.8.3.13 Use the measured bearing retainer ID to determine the required bushing OD.

Port

Stbd

Average bearing retainer ID (Figure 561-I-15):

Enter bushing press fit (see above):

Final bushing OD (retainer ID plus press fit):

561-I.8.3.14 Machine replacement bushings to the final dimensions specified in accordance with drawings, References 561-I.8.5.1 and 561-I.8.5.2. Follow precautions and guidance in paragraph 561-I.10 of this procedure when machining the self-lubricated bearing components.

#### NOTE

Do not machine grease holes and grease grooves in replacement bearing components.

561-I.8.3.15 Clean all surfaces of remaining components that contact self-lubricated bearing components until free of grease and debris.

561-I.8.3.16 Chill bushings in dry ice or liquid nitrogen. Place bushing into bearing retainer, making sure the bushing is not cocked, and using even pressure all around the edge of the bushing. This step must be completed before the bushing is allowed to warm up.

561-I.8.3.17 Carefully install each pintle bearing assembly into bearing brackets.

#### NOTE

Do not lift or support the pintle bearing with a chain or rope through the bearing bore.

561-I.8.3.18 Complete the reassembly of pintles and pintle bearings in accordance with applicable NAVSEA drawings.

#### NOTE

Use caution and ensure pintles are centered when re-installing pintles in bearings to prevent damage to the bearing surface.

561-I.8.3.19 Tighten mounting bolts in accordance with applicable NAVSEA drawings.

561-I.8.3.20 Spray water on bearing surfaces prior to exercising the stern planes in drydock.

561-I.8.4 Prior And/or Concurrent Alterations. The following prior ship alterations (shipalts) are applicable. The installation details are based on prior completion of these shipalts:

561-I.8.4.1 SSN 688 Class: None identified.

561-I.8.4.2 SSBN 726 Class: None identified.

561-I.8.5 References.

561-I.8.5.1 MPR Drawing 1059-126-35. "SSN 688 Class, Stern Diving Pintle Bearing Repair, Non-Metallic Bearings."

561-I.8.5.2 General Dynamics, EBDiv, Engineering Notice DM 120889. "Main Stock Journal Bearings, Pintle Journal Bearings, and Thrust Bearing." [Stern Diving Gear]

561-I.8.5.3 NAVSEA Drawing 4403816. "SSN 688 Class Submarine, Stern Diving Plane Stocks, Pintles, Bearings & Yoke."

561-I.8.5.4 NAVSEA Drawing 4643344. "SSBN Trident Class, Stern Plane Stock, Yoke, Bearing & Post."

561-I.8.5.5 Maintenance Standard (MS) 5560-081-008. "Overhaul Stern Diving Gear (Drydocking Required)."

561-I.8.5.6 Maintenance Standard (MS) 5560-081-038. "Restore External Parts of Stern Diving Gear."

561-I.8.5.7 General Dynamics, EBDiv Drawing 41057-566000. "Stern Plane Pintle Bearing Replacement Procedure."

561-I.8.6 Maintenance Requirement Parts List. Refer to [Tables 561-I-17](#) and [561-I-18](#), and drawings, References [561-I.8.5.1](#) and [561-I.8.5.2](#) for materials required to accomplish these repairs for the applicable submarine class.

#### NOTE

The ordering dimensions specified in the referenced drawing include allowance for field machining components to the final dimensions. Field machining is done after as-built measurements are performed.

561-I.8.7 Final Inspection. Perform and record pintle bearing diametral clearance measurements in accordance with Maintenance Standards or ship drawings as applicable.

Pintle and Bracket Measurements (After any Refurbishing)				
Location	Port		Starboard	
	Pintle OD	Bracket ID	Pintle OD	Bracket ID
0°				
45°				
90°				
135°				
Average				

Pintle Bearing Retainer Measurements				
Location	Port		Starboard	
	ID	OD	ID	OD
0°				
45°				
90°				
135°				
Average				

Bushing Measurements						
Location	Port Side			Starboard Side		
	Bushing ID	Bushing <sup>(1)</sup> OD	Bushing <sup>(2)</sup> OD	Bushing ID	Bushing <sup>(1)</sup> OD	Bushing <sup>(2)</sup> OD
0°						
45°						
90°						
135°						
Average						

<sup>(1)</sup> Prior to machining final OD.

<sup>(2)</sup> After machining final OD.

Figure 561-I-16 Bearing Measurement Worksheet

**Table 561-I-17** Summary of SSN 688 Class Stern Plane Pintle Bearing Material Replacements

Item	Qty	Component Applicable Dwg / Pc #	Materials	
			Existing	Replacement
1	2	Bearing 4403816/Pc 36	Stellite Alloy 20, Mil-C-15345G	Self-Lubricated Bearing CID A-A-50602
2	2	Pintle Sleeve 4403816/Pc 37	Stellite Alloy 21, Mil-C-15345G	K-Monel QQ-N-286F
3	2	Bearing Retainer 4403816/Pc 34	H-Monel Alloy 16, Mil-C-15345G	Ni-Al-Brz MIL-B-24480
4	2	Retainer Plate	N/A	Monel QQ-N-281, Cl. A

**Table 561-I-18** Summary of SSBN 726 Class Stern Plane Pintle Bearing Material Replacements

Item	Qty	Component Applicable Dwg / Pc #	Materials	
			Existing	Replacement
1	2	Bearing 4643345/Pc 4	Stellite Alloy 20, Mil-C-15345G	Self-Lubricated Bearing CID A-A-50602
2	2	Sleeve 4643345/Pc 5	Stellite Alloy 21, Mil-C-15345G	K-Monel QQ-N-286F
3	2	Bearing Retainer 4643345/Pc 3	H-Monel Alloy 16, Mil-C-15345G	Ni-Al-Brz MIL-B-24480
4	2	Retainer Plate	N/A	Monel QQ-N-281, Cl. A

**561-I.9 RUDDER STOCK AND CARRIER BEARING REPAIR.**

561-I.9.1 Purpose And Scope. These paragraphs provide detailed requirements for installation of SSN 688 and SSBN 726 Class submarine rudder stock and carrier bearing component replacements. The affected bearing components are illustrated in [Figure 561-I-16](#). The bearing repairs include the following:

## I.9.1.1 Upper and lower stock bearings:

1. Substituting self-lubricated bearings for existing Stellite (Alloy 20) spherical bearing rings.
2. Substituting K-Monel (QQ-N-286) sleeves for existing Stellite (Alloy 21) outboard stock sleeves.
3. Substituting Nickel-Aluminum-Bronze (MIL-B-24480) bearing retainers for existing H-Monel (Alloy 16) bushings.

## I.9.1.2 Lower rudder carrier bearings:

1. Substituting Karon V coated K-Monel (QQ-N-286) thrust washers for existing Stellite (Alloy 20) upper thrust washers.
2. Substituting Inconel 718 thrust washers for existing Stellite (Alloy 21) lower thrust washers.
3. Substituting Karon V coated K-Monel (QQ-N-286) bearing collars for existing H-Monel (Alloy 16) bearing collars.

These replacements will eliminate greasing requirements, reduce noise, reduce wear on the bushings, provide insulation from galvanic corrosion and extend the period between replacement of these parts.

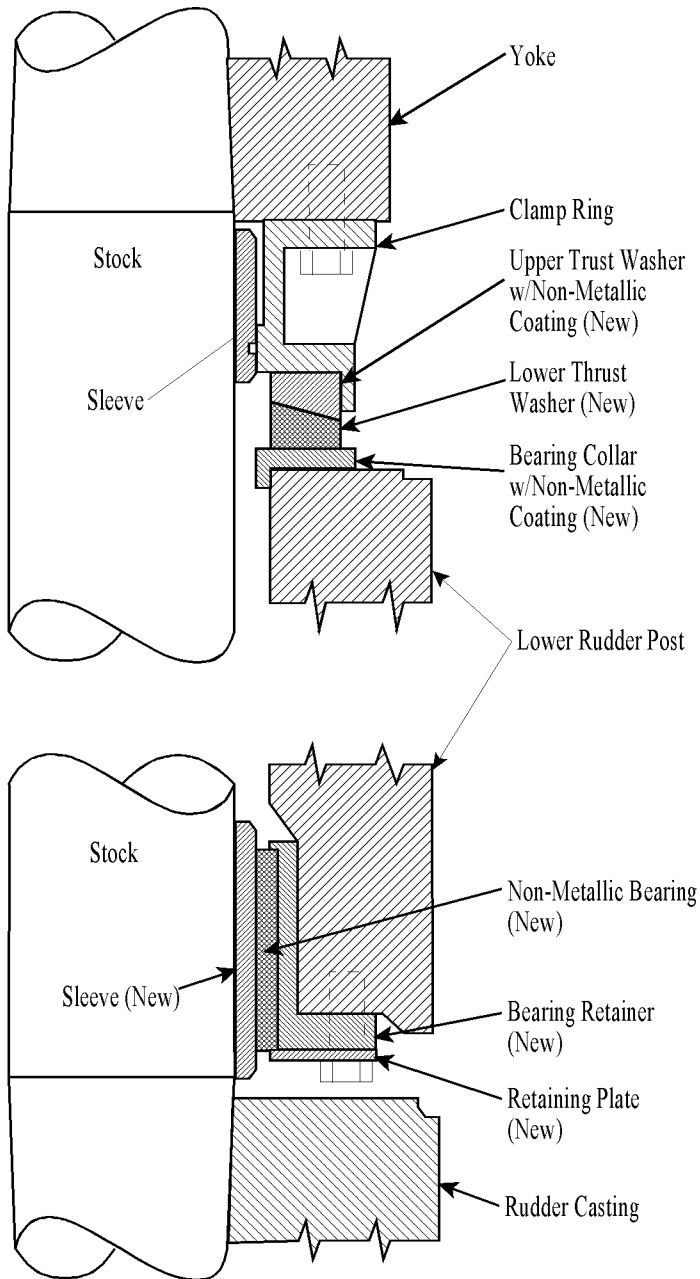

Figure 561-I-17 Typical Rudder Bearing Repairs (Lower Rudder Shown)

561-I.9.2 Repair Requirements. The metallic stock bearings and carrier bearings associated with the SSN 688 and SSBN 726 Class submarine rudder bearing assemblies shall be replaced with self-lubricated, extended wear parts in accordance with drawings, References [561-I.9.5.1](#) and [561-I.9.5.2](#). In addition, the mating metallic bearing components will be replaced with K-Monel or Monel parts for compatibility with the bearing components.

561-I.9.2.1 All general requirements specified in [paragraphs 561-I.2](#) through [561-I.2.16.3](#) of this procedure shall be met when performing the bearing modifications and repairs.

561-I.9.2.2 Criteria to initiate these repairs during overhaul shall be MS's 5560-081-033 (latest rev.) for SSN 688 Class or MS 5560-081-009 (latest rev.) for SSBN 726 Class stock bearing diametral clearance.

561-I.9.2.3 Criteria to initiate these repairs during a ships' operating cycle shall be based primarily on noise. As long as the components are not generating detectable noise and the system is operationally quiet, the repairs will not be initiated.

561-I.9.2.4 The clearance limits following repair shall be as specified on the drawings, References [561-I.9.5.1](#) and [561-I.9.5.2](#).

561-I.9.3 Detailed Installation Requirements. The following installation actions are required to accomplish this repair:

561-I.9.3.1 Remove the rudder and stock assemblies from the submarine. Removal and re-installation of these heavy components is accomplished in accordance with existing NAVSEA drawings and standard shipyard practices. General Dynamics/Electric Boat Drawings 41022-566000 and 41033-566000 (latest rev.) are suggested handling procedures for SSBN 726 Class submarines.

561-I.9.3.2 Disassemble the upper and/or lower bearings from the rudder post, as applicable.

561-I.9.3.3 Lift yoke and disassemble the carrier bearing from the yoke.

561-I.9.3.4 Remove the inboard and outboard stock sleeves from the stock.

561-I.9.3.5 Disconnect the existing grease lines serving the rudder stock and carrier bearings, as applicable. Remove the flex hose tubing of the applicable grease lines between the bearing connections and the nearest terminal block. Remove the tube fittings from the bearing connection and plug the vacant orifices. Apply PR-380M thread sealant to plug threads prior to installation. Also plug the appropriate grease line terminal block/grease manifold ports and tube ends. Re-label greasing manifold accordingly.

561-I.9.3.6 Inspect condition of stocks, inboard sleeves, and bearing posts for acceptability per Maintenance Standard requirements.

561-I.9.3.7 Clean all grease, rust, and corrosion from the stocks, inboard sleeves, and posts. Refurbish stock and post surfaces as necessary to restore to original design conditions. Refurbish or replace inboard stock sleeves as required. Contact NAVSEA 92T for guidance on acceptable processes and procedures for stock repairs. Preserve exposed stock surfaces with epoxy paint (Mil-P-23236, Type 1, Class 2) in accordance with the applicable NAVSEA drawings.

561-I.9.3.8 Using [Figure 561-I-17](#), measure and record stock, bearing post, and bearing retainer diameters for fit-up and compliance with design drawing dimensional criteria. Correct post ID out-of-roundness as necessary.

561-I.9.3.9 Final machine bearing retainer OD as necessary for proper fit up with bearing post ID in accordance with drawings, References [561-I.9.5.1](#) and [561-I.9.5.2](#).

Port Stbd

Average post ID ([Figure 561-I-17](#)):

Enter bushing clearance or press fit:

Final bushing OD (post ID plus press or minus clearance):

561-I.9.3.10 Use the measured stock OD to determine the replacement outboard sleeve final dimensions.

Port Stbd

Average stock OD ([Figure 561-I-17](#)):

Enter sleeve shrink fit:

Final sleeve ID (stock OD minus shrink fit):



561-I.9.3.11 Machine replacement sleeves to the final dimensions specified in accordance with drawings, References [561-I.9.5.1](#) and [561-I.9.5.2](#).

561-I.9.3.12 Heat new outboard sleeves to 300 to 500°F using an oven or heating blanket. Do not use a torch. Install sleeves on stock using even pressure all around the edge of the sleeve. A solid stop should be used to control positioning of the sleeves on the stock.

561-I.9.3.13 After the sleeves have cooled, wrap the stock sleeve surface with a soft rubber sheet (about 1/8 to 1/4 inch thick) and tape the sheet to the stock to protect the sleeves until the stock/rudder is re-installed.

561-I.9.3.14 Install inboard sleeves per [paragraph 561-I.9.3.11](#).

561-I.9.3.15 Use [Figure 561-I-17](#) to measure the replacement bushing ID. Select the highest press fit in the required range in order to minimize the final clearance. Verify adequate final clearance as follows:

	Port	Stbd
--	------	------

Average bushing ID ([Figure 561-I-17](#)):

Enter required bushing press fit:

Installed ID (measured ID minus press fit):

Measure installed sleeve OD in four places 45° apart and record average:

Final installed clearance (installed bushing ID minus installed sleeve OD):

561-I.9.3.16 Use the measured bearing retainer ID to determine the required bushing OD.

	Port	Stbd
--	------	------

Average bearing retainer ID ([Figure 561-I-17](#)):

Enter bushing press fit (see above):

Final bushing OD (bearing retainer ID plus press fit):

561-I.9.3.17 Machine replacement bushings to the final dimensions specified in accordance with drawings, References [561-I.9.5.1](#) and [561-I.9.5.2](#). Follow precautions and guidance in [paragraph 561-I.10](#) of this procedure when machining the self-lubricated bearing components.

#### NOTE

Do not machine grease holes and grease grooves in replacement bearing components.

561-I.9.3.18 Clean all surfaces of remaining components that contact self-lubricated bearing components until free of grease and debris.

561-I.9.3.19 Chill bushings in dry ice or liquid nitrogen. Place bushing into bearing retainer, making sure the bushing is not cocked, and using even pressure all around the edge of the bushing. This step must be completed before the bushing is allowed to warm up.

561-I.9.3.20 Carefully re-install each bearing assembly into bearing post.

**NOTE**

Do not lift or support the bushing with a chain or rope through the bearing bore. Use a shackle through one of the bushing mounting bolt holes.

561-I.9.3.21 Reassemble carrier bearing using replacement bearing parts in accordance with applicable NAVSEA drawings.

561-I.9.3.22 Install each rudder/stock assembly in accordance with the applicable NAVSEA drawings and established shipyard procedures. Ensure stock is centered and use extreme caution when guiding the stock through the bearing to prevent damage to the bearing components.

561-I.9.3.23 Verify all fasteners are tightened in accordance with applicable NAVSEA drawings.

561-I.9.3.24 Complete assembly of remaining components in accordance with applicable NAVSEA drawings.

561-I.9.3.25 Spray water on bearing surfaces prior to exercising the rudders in drydock.

561-I.9.4 Prior And/or Concurrent Alterations. The following prior ship alterations (shipalts) are applicable. The installation details are based on prior completion of these shipalts:

561-I.9.4.1 SSN 688 Class: None identified.

561-I.9.4.2 SSBN 726 Class:

a. TZ 0088 -- Replaces carrier bearing thrust collar dowel pins.

b. TZ 0176 -- Modifies upper rudder cavity.

561-I.9.5 References.

561-I.9.5.1 MPR Drawing 1059-126-39. "SSN 688 Class, Rudder Stock and Carrier Bearing Repair, Non-Metallic Bearing."

561-I.9.5.2 General Dynamics, EBDiv, Engineering Notice DM 120890. "Main Stock Journal Bearings and Carrier Bearing." [Rudder]

561-I.9.5.3 NAVSEA Drawing 4403809. "SSN 688 Class Submarine, Rudder Stocks, Posts & Yoke."

561-I.9.5.4 NAVSEA Drawing 6225162. "SSN 688 Class Submarine, Rudder Stocks, Posts & Yoke."

561-I.9.5.5 NAVSEA Drawing 4403810. "SSN 688 Class Submarine, Rudder Bearings and Sleeves."

561-I.9.5.6 NAVSEA Drawing 4643331. "SSBN Trident Class, Rudder Stock, Yoke & Details."

561-I.9.5.7 NAVSEA Drawing 4643334. "SSBN Trident Class, Rudder Carrier and Bearings."

561-I.9.5.8 Maintenance Standard (MS) 5560-081-009. "Overhaul Steering Gear (Drydock Required)."

561-I.9.5.9 Maintenance Standard (MS) 5560-081-033. "Restore External Parts of Steering Gear."

561-I.9.5.10 General Dynamics, EBDiv Drawing 41022-566000. "Upper Rudder Replacement Procedure."

561-I.9.5.11 General Dynamics, EBDiv Drawing 41033-566000. "Lower Rudder Replacement Procedure."

561-I.9.6 Maintenance Requirement Parts List. Refer to [Tables 561-I-19](#) and [561-I-20](#), and drawings, References [561-I.9.5.1](#) and [561-I.9.5.2](#) for materials required to accomplish these repairs for the applicable submarine class.

#### NOTE

The ordering dimensions specified in the referenced drawing include allowance for field machining components to the final dimensions. Field machining is done after as-built measurements are performed.

561-I.9.7 Final Inspection. Perform and record bearing diametral and thrust clearance measurements in accordance with Maintenance Standards or ship drawings as applicable.

Stock and Bearing Post Measurements (After any Refurbishing)				
Location	At Upper Bearing		At Lower Bearing	
	Stock OD	Post ID	Stock OD	Post ID
0°				
45°				
90°				
135°				
Average				

Bearing Retainer Measurements				
Location	Upper Bearing		Lower Bearing	
	ID	OD	ID	OD
0°				
45°				
90°				
135°				
Average				

Bushing Measurements						
Location	Upper Bearing			Lower Bearing		
	Bushing ID	Bushing <sup>(1)</sup> OD	Bushing <sup>(2)</sup> OD	Bushing ID	Bushing <sup>(1)</sup> OD	Bushing <sup>(2)</sup> OD
0°						
45°						
90°						
135°						
Average						

<sup>(1)</sup> Prior to machining final OD.

<sup>(2)</sup> After machining final OD.

Figure 561-I-18 Bearing Measurement Worksheet

**Table 561-I-19** Summary of SSN 688 Class Rudder Stock and Carrier Bearing Material Replacements

Item	Qty	Component Applicable Dwg / Pc #	Materials	
			Existing	Replacement
1	2	Bearing Ring (Upper and Lower Rudder) 4403810/Pc 3	Stellite Alloy 20, Mil-C-15345G	Self-Lubricated Bearing CID A-A-50602
2	2	Sleeve, Outboard (Upper and Lower Rudder) 4403810/Pc 1	Stellite Alloy 21, Mil-C-15345G	K-Monel QQ-N-286F
3	2	Bushing/Retainer (Upper and Lower Rudder) 4403810/Pc 4	H-Monel Alloy 16, Mil-C-15345G	Ni-Al-Brz MIL-B-24480
4	2	Retainer Plate	N/A	Monel QQ-N-281
5	1	Upper Thrust Washer (Lower Rudder) 4403810/Pc 15	Stellite Alloy 20, Mil-C-15345G	Karon V coated K-Monel QQ-N-286
6	1	Lower Thrust Washer (Lower Rudder) 4403810/Pc 14	Stellite Alloy 21, Mil-C-15345G	Inconel 718
7	1	Bearing Collar (Lower Rudder) 4403810/Pc 16	H-Monel Alloy 16, Mil-C-15345G	Karon V coated K-Monel QQ-N-286

**Table 561-I-20** Summary of SSBN 726 Class Rudder Stock and Carrier Bearing Material Replacements

Item	Qty	Component Applicable Dwg / Pc #	Materials	
			Existing	Replacement
1	2	Bearing Ring (Upper and Lower Rudder) 4643334/Pc 50	Stellite Alloy 21, Mil-C-15345G	Self-Lubricated Bearing CID A-A-50602
2	2	Sleeve, Outboard (Upper and Lower Rudder) 4643331/Pc 25	Stellite Alloy 20, Mil-C-15345G	K-Monel QQ-N-286F
3	2	Bushing (Upper and Lower Rudder) 4643334/Pc 1	H-Monel Alloy 16, Mil-C-15345G	Ni-Al-Brz MIL-B-24480
4	2	Retainer Plate	N/A	Monel QQ-N-281
5	1	Upper Thrust Washer (Lower Rudder) 4643334/Pc 5	Stellite Alloy 20, Mil-C-15345G	Karon V coated K-Monel QQ-N-286
6	1	Lower Thrust Washer (Lower Rudder) 4643334/Pc 4	Stellite Alloy 21, Mil-C-15345G	Inconel 718
7	1	Bearing Collar (Lower Rudder) 4643334/Pc 3	H-Monel Alloy 16, Mil-C-15345G	Karon V coated K-Monel QQ-N-286

**561-I.10 MACHINING REQUIREMENTS FOR SELF-LUBRICATED BEARING MATERIALS.**

561-I.10.1 Purpose. These paragraphs provide guidance for the machining of self-lubricated and non-metallic bearing materials, including UHMWPE, Tuffite, and Orkot. Guidance includes tool selection, coolant requirements, cutting speeds and feed rates for different machining operations.

561-I.10.2 Machining Requirements. In general, machining techniques for self-lubricated and non-metallic bearing materials are similar to those employed with metals such as aluminum. However, there are a few important considerations for machining these types of bearing materials.

- Cutting tools should be kept very sharp to avoid frictional heating of the part being machined. Frictional heating can result

in poor tolerance and finish, oxidation, discoloration and in the extreme can cause melting of the material. Typically, cutting tools which were previously used to machine metals should not be used to machine non-metallic bearing materials.

- Adequate cutting tool clearances need to be maintained during machining operations. Insufficient tool clearances can cause the build-up of excessive frictional heat.
- Cutting speeds and feed rates should be chosen to avoid excessive heating of the material being machined.
- The material to be machined should be properly supported to minimize distortion. This is particularly important with UHMWPE, which tends to warp during machining. For rings such as sleeves or bushings, a close fitting arbor should be inserted into the ring. Cutting tools should also be properly supported.
- Care should be taken to ensure the work area is clean of all metal filings. Contamination of non-metallic bearing wear surfaces with metal filings will result in excessive wear and reduced bearing life.
- Dimensions shown on the design drawings are for room temperature (70°F). Corrections to the design dimensions for non-metallic parts may be necessary if the shop temperature is not within 60 to 80°F.

Specific guidance for several non-metallic bearing materials is provided below.

### **WARNING**

**Airborne particles generated when machining or sanding non-metallic materials may cause irritation. Use of a vacuum dust extraction system is recommended. Operators should wear dust particle masks.**

561-I.10.3 UHMWPE. UHMWPE (ultra high molecular weight polyethylene) can be sawn, turned, planed, milled and drilled on woodworking or metal-working machines. To obtain high quality surfaces, tools should always be sharp. High speed steel tools may be used for short periods of time, if the cutting edges are kept sharp. For production runs, diamond tipped or tungsten carbide tools should be used. At lower cutting speeds cooling is not required but at higher cutting speeds, water cooling or the use of cutting oils is recommended. In all cases care must be taken to avoid heat build-up in the machining operation so that the material does not smear on the cutting faces.

For close tolerances (for example, on stave thicknesses), UHMWPE should first be rough machined, then stress relieved. Stress relief is accomplished by heating to 240°F then slowly cooling under a thermal blanket for approximately 12 hours. Note that Ultra Wear type "TH" should not be stress relieved.

UHMWPE has a high thermal expansion coefficient (about  $1 \times 10^{-4}$  in/in/°F). However, the tightest tolerances are required on stave thicknesses and thrust washer thicknesses, which are about 0.5 inches. These relatively small dimensions will be affected by less than 0.001 inches for shop temperatures between 50 and 90°F.

Turning/Milling - - UHMWPE may be machined without difficulty on a lathe and a high quality finish attained. Cooling is not usually necessary but care must be taken to remove all swarf. Only for large depth of cut is cooling with compressed air or cutting oils likely to be required. Cutting speeds up to 2000 fpm may be used.

Drilling - - UHMWPE can be drilled on drilling machines and on lathes and milling machines. Twist drills are generally used but for larger diameters circular cutters may also be used. With good swarf removal local overheating can largely be avoided. If excessive heating should occur in high speed drilling, cooling may be carried out with compressed air, water, or cutting oil.

561-I.10.4 TufLite. TufLite is a fiberglass material. When machining TufLite, use carbide or diamond tipped tools. Water or coolant should be used to reduce dust. Guidance for several machining operations is provided below.

The thermal expansion coefficient for TufLite is relatively low (about  $7 \times 10^{-6}$  in/in/°F), and is similar to that for steel. Consequently, corrections for shop temperature differences are not required for temperatures between 50 and 90°F.

Turning/Milling - - In general, machining speeds and cutting feeds are similar to turning wood.

Cutting - - Use a silicon carbide abrasive wheel (90-120 grit K-RA) or a diamond cutoff wheel ranging in width from 0.060 to 0.100 inches. Use water or coolant to keep the dust from getting to the operator. Cut through the fiberglass and stop, then slide the bearing off the arbor and cut the fabric with a knife. A hand grinder or 80 grit paper can be used to remove the burrs or break the corner. Care should be taken not to roll the fabric back into the bore.

Grinding -- Silicon carbide grinding wheels work the best, but any grinding wheel will work for small quantities. For rough stock removal, remove up to 0.050 inches per pass. For finish stock removal, remove 0.004 to 0.010 inches per pass with one wiping pass. Part speed is based on finish requirements.

561-I.10.5 Orkot TXM/TLM-Marine. Orkot is a thermoset composite reinforced with woven synthetic fibers. Orkot is readily machinable by conventional equipment and techniques. As a general rule, machining methods used for brass or aluminum apply to Orkot. Tungsten carbide-tipped tools should be used to obtain a fine finish. High-speed steel tools can be used for machining where accuracy below 0.005 inches is not required and for small-quantity production. Orkot should be machined dry, without coolant. However, adequate dust extraction should be used. If extraction is not available, operators should wear dust particle masks while working with the material. Guidance for several machining applications is provided below.

The thermal expansion coefficient for Orkot is about  $2 \times 10^{-5}$  in/in/°F for temperatures between 40 and 100 F. Consequently, corrections for shop temperature differences may be required if the shop temperature is not within 65 to 75°F. The table below shows the correction required to the ID and OD of various size bearing parts at different shop temperatures. Add these corrections to the ID and OD dimensions shown on the design drawings.

Turning/Milling - - For rough cutting, the cutting speed should be 1000-1100 fpm and the feed rate should be 0.010-0.025 inches/rev. For finished cutting the cutting speed should be 1450 fpm and the feed rate should be 0.003-0.008 inches/rev. For milling, feeds should be limited to 0.01-0.015 inches/tooth to prolong cutter life and reduce excessive heat build-up.

Drilling - - Drilling should be performed with high-speed tungsten twist drills at 100-120 fpm peripheral speed. Feed should be limited to 2-3 inches per minute.

Temperature Corrections for Orkot\*

Shop Temp. (°F)	Bearing Part ID or OD Dimension (inch)							
	4 - 6	6 - 8	8 - 10	14 - 16	16 - 18	18 - 20	20 - 22	22 - 24
45	-0.003	-0.004	-0.005	-0.008	-0.009	-0.010	-0.011	-0.012
50	-0.002	-0.003	-0.004	-0.006	-0.007	-0.008	-0.008	-0.009
55	-0.002	-0.002	-0.003	-0.005	-0.005	-0.006	-0.006	-0.007
60	n/r	n/r	-0.002	-0.003	-0.003	-0.004	-0.004	-0.005
65	n/r	n/r	n/r	-0.002	-0.002	-0.002	-0.002	-0.002
70	n/r	n/r	n/r	n/r	n/r	n/r	n/r	n/r
75	n/r	n/r	n/r	0.002	0.002	0.002	0.002	0.002
80	n/r	n/r	0.002	0.003	0.003	0.004	0.004	0.005
85	0.002	0.002	0.003	0.005	0.005	0.006	0.006	0.007
90	0.002	0.003	0.004	0.006	0.007	0.008	0.008	0.009
95	0.003	0.004	0.005	0.008	0.009	0.010	0.011	0.012
100	0.003	0.004	0.005	0.009	0.010	0.011	0.013	0.014

\*Corrections to be added to ID and OD as shown on design drawings. Correction is equal to  $(2 \times 10^{-5} \text{ in/in/°F}) \times (\text{diameter}) \times (\text{shop temp.} - 70^\circ\text{F})$ .





## APPENDIX J.

### BOW PLANE OUTBOARD CABLE INTEGRITY

#### **561-J.1 Determining Material Condition of Retractable Bow Plane (RBP) Outboard Sensor Cabling Assemblies**

The following provides information to determine RBP outboard cable assembly integrity. RBP outboard sensor performance is sensitive to seawater intrusion. Thus, verification of cable assembly integrity is critical to monitoring system performance. Verification of cable assembly integrity is performed by both visual and, preferably, electrical checks of cable assembly condition. Electrical checks of cable assembly condition includes measurement of cable assembly insulation resistance. If the cable assembly integrity has not been violated and the cable is submerged, the expectation is that the cable insulation resistance is greater than one megaohm. Maintenance corrective action is necessary if the cable assembly insulation resistance is less than one megaohm.

#### **561-J.2 Verification of Replacement Cable Integrity**

Before replacing cabling, verification of adequate cable integrity is necessary. Verification of cable integrity is performed by both visual and electrical checks of a dry cable assembly. Cable insulation resistance, as indicated by [Figure 561-J-1](#), is typically temperature dependent. This information is significant since the expectation for cable insulation resistance is used as the criteria for verification of cable integrity. Therefore, when evaluating results from measurement of cable insulation resistance, compare these values to the expected results of [Figure 561-J-1](#) to determine adequacy of cable integrity.

#### **561-J.3 Care in Replacing Cable**

When installing a cable, care must be exercised to avoid damaging the cable by crimping or introducing sharp bends in the cable. Additionally, see **NSTM Chapter 300, Electric Plant, General**, for more details on cable installation.

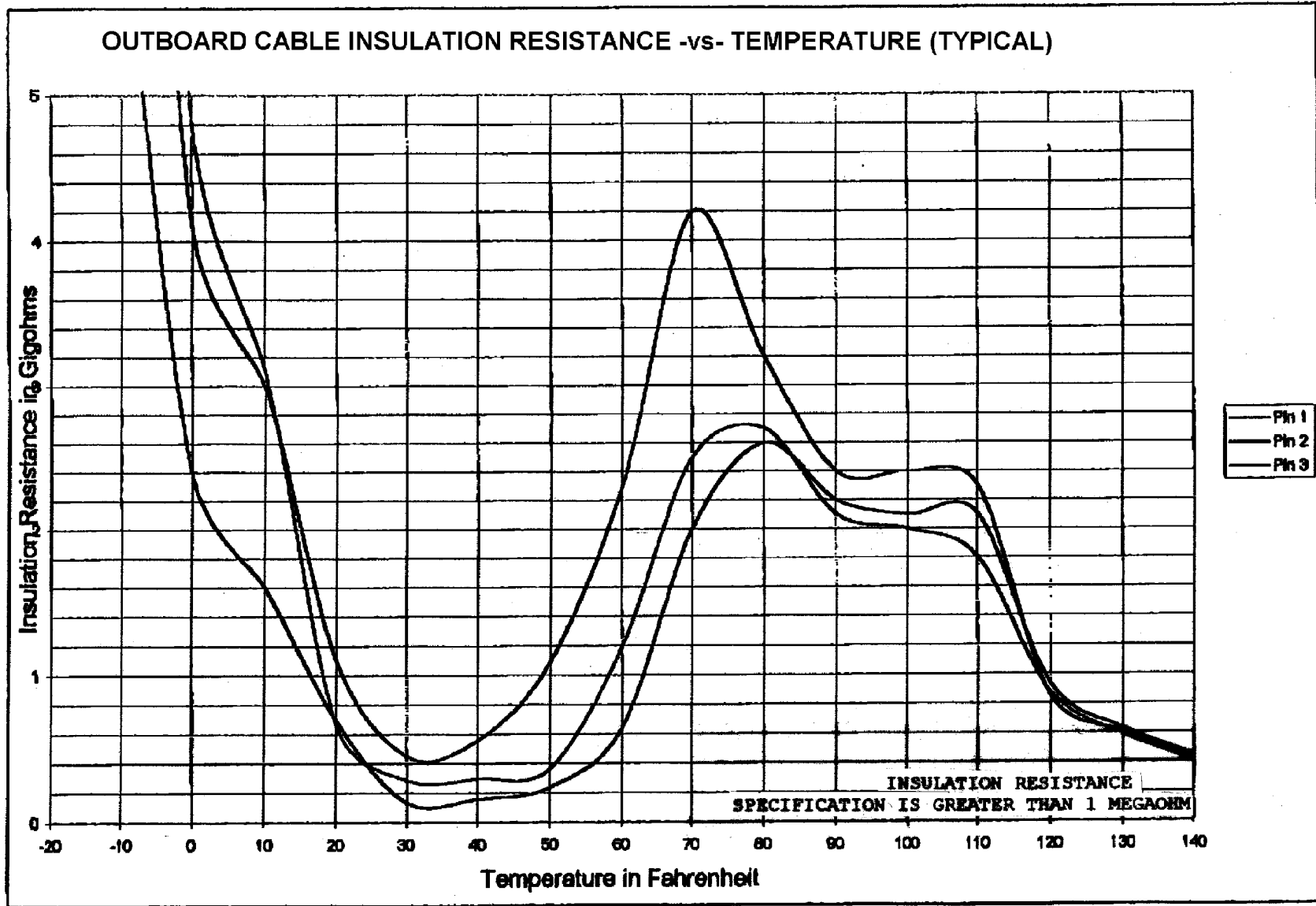

Figure 561-J-1. OUTBOARD CABLE INSULATION RESISTANCE vs TEMPERATURE (TYPICAL)

**APPENDIX****TECHNICAL MANUAL DEFICIENCY/EVALUATION REPORT (TMDER)****NOTE**

Ships, training activities, supply points, depots, Naval Shipyards, and Supervisors of Shipbuilding are requested to arrange for the maximum practical use and evaluation of NAVSEA technical manuals. All errors, omissions, discrepancies, and suggestions for improvement to NAVSEA technical manuals shall be reported to the Commander, NAVSURFWARCENDIV, 4363 Missile Way, Port Hueneme, CA 93043-4307 on NAVSEA/ SPAWAR Technical Manual Deficiency/Evaluation Report (TMDER), NAVSEA Form 4160/1. To facilitate such reporting, print, complete, and mail NAVSEA Form 4160/1 below or submit TMDERS at web site <http://nsdsa.phdnswc.navy.mil/tmder/tmder.htm>. All feedback comments shall be thoroughly investigated and originators will be advised of action resulting therefrom. Extra copies of NAVSEA Form 4160/1 may be requisitioned from DDSP Susquehanna Pennsylvania, 05 E Street, Mechanicsburg, PA 17055-5003. (S/N 0116-LP-019-5300)

**TMDER / MAILER**

